



GOVERNMENT OF BERMUDA

Ministry of Public Works

Department of Works and Engineering

September 16, 2024

Dear Respondents,

Ref: 44-11-110 Watford Bridge Painting

This Addendum #1 contains (2) pages including this front page as well as a PDF binder of drawings.

The following addendum supersedes information contained in the RFP to the extent referenced.

This addendum forms part of the RFP documents and will be subject to all of the conditions set out in the contract.

PART 1 – Clarifications and Revisions

- Historic drawings for Watford bridge are included with this Addendum.

END OF PART 1

PART 2 – Questions from Respondents

1. The issued Coating Specification includes two options to quote for. Do respondents need to provide two separate prices?

A) Please provide costs for a full bridge re-painting at 20,800 ft² (i.e. option 1 within coating specification). Within the pricing schedule, please include ft² unit rates for steel painting for our records.

2. Q) Paint systems have been specified within IEPC coating report (TNEMEC and Sherwin Williams Coating Systems), do respondents have to use these named suppliers?

A) The government would like respondents to quote using these pre-approved coating systems. However, alternative paint systems can be proposed if they meet the specifications as listed within the IEPC report. Data/technical sheets would be required, and a review and approval process would be undertaken with government authority to reject proposed painting systems.

To aid with respondents' bids, please contact the following personnel to assist with quotation:

TNEMEC;

Caleb Parker

parker@tnemec.com

Sherwin Williams;

Bob Spano

robert.l.spano@sherwin.com

3. Q) Is Laser De-Rusting acceptable?

A) Laser de-rusting is acceptable.

END OF PART 2

CONTENTS.

Drawings for construction of New Watford Bridge.

- 7722 / 3 / 1 — Site Plan
- / 2 — Vertical and Horizontal Alignment
 (to be read in conjunction with Setting - Out Book.)
- / 3 — Layout of Bridge Approaches.
- / 4 — General Arrangement
- / 5 — Foundation Plan.
- / 6 — Somerset Island Approach. Scheme 1.
- / 7 — Somerset Abutment. General Arrangement. Scheme 1.
- / 8 — Somerset Abutment. R.C. Details. Scheme 1.
- / 9 — Somerset Island Approach. Scheme 2.
- / 10 — Somerset Abutment. General Arrangement. Scheme 2.
- / 11 — Somerset Abutment. R.C. Details Scheme 2.
- / 12 — Watford Abutment. General Arrangement.
- / 13 — Watford Abutment. R.C. Details.
- / 14 — Details of Piers.
- / 15 — Deck Steelwork. Sheet 1.
- / 16 — Deck Steelwork. Sheet 2.
- / 17 — Deck Slab. General Arrangement.
- / 18 — Deck Slab. R.C. Details.
- / 19 — Guardrail and Lighting Details.
- / 20 — Bearing Schedule and Details.

Drawings for demolition of existing Watford Bridge.

- 7722 4 / 1 — Bridge Details. Sheet 1.
- 4 / 2 — Bridge Details. Sheet 2.

Note :- Drawings are presented at size A1 reduced from original drawing size A0.

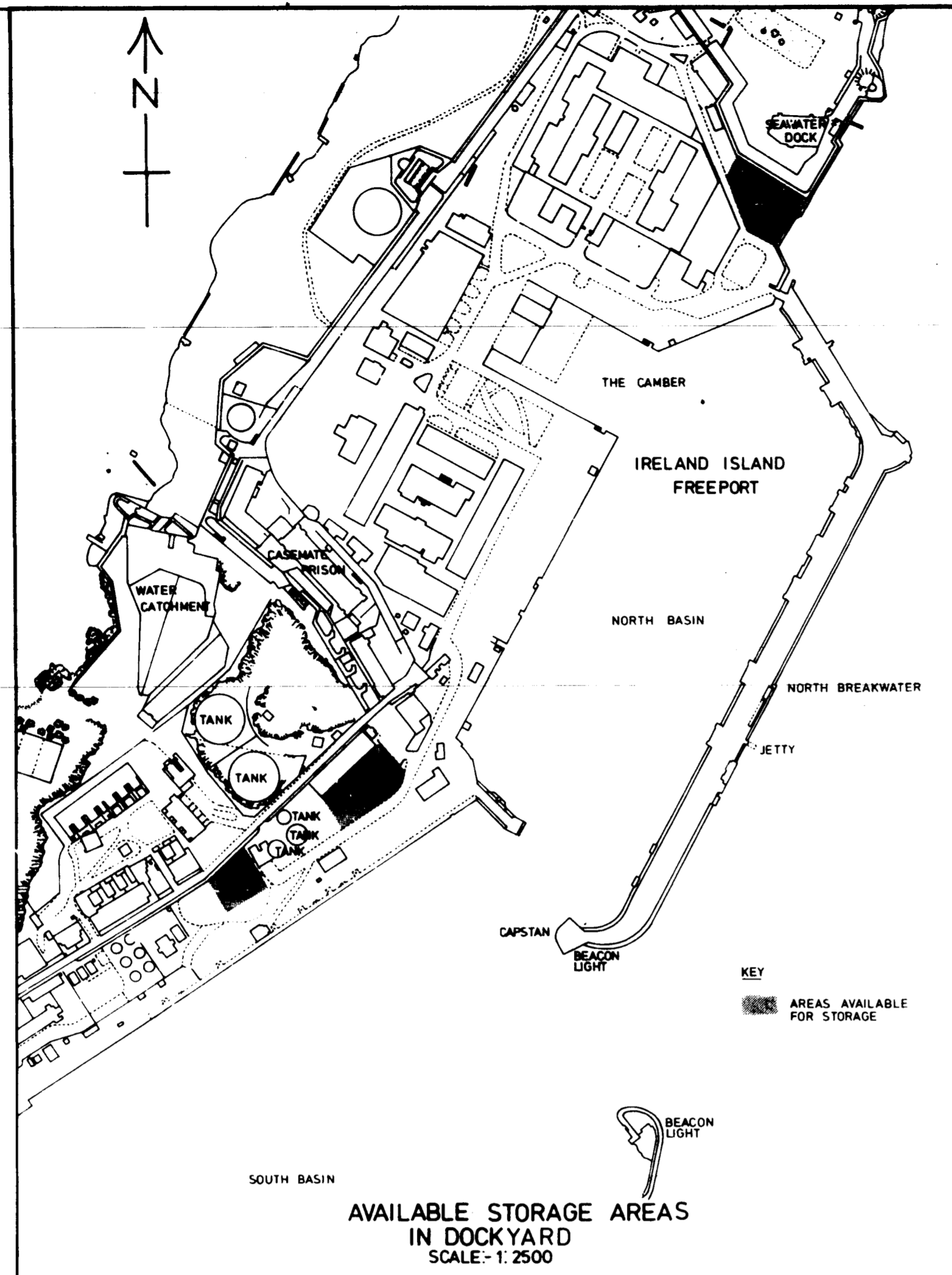

P.W.D. SURVEY STATIONS	LOCATION / COMMENT	EASTING	NORTHING
1		200.00	200.00
2		165.77	228.72
3		354.10	234.02
4		436.61	315.08
5		456.72	264.94
8		381.56	346.31
9	CR WALL - RD SIDE	441.86	307.30
10	TOP CR-SEA WALL	432.02	316.18
11	Q JOINT & Q BRIDGE	414.80	273.62
12	Q JOINT & Q BRIDGE	368.45	239.84
13	Q JOINT & Q BRIDGE	304.94	193.56
14	CR BUILDING	263.08	185.62
15	END RETAINING WALL SEA SIDE	213.05	181.69

STATION INDICATED ON PLAN THUS: (5)

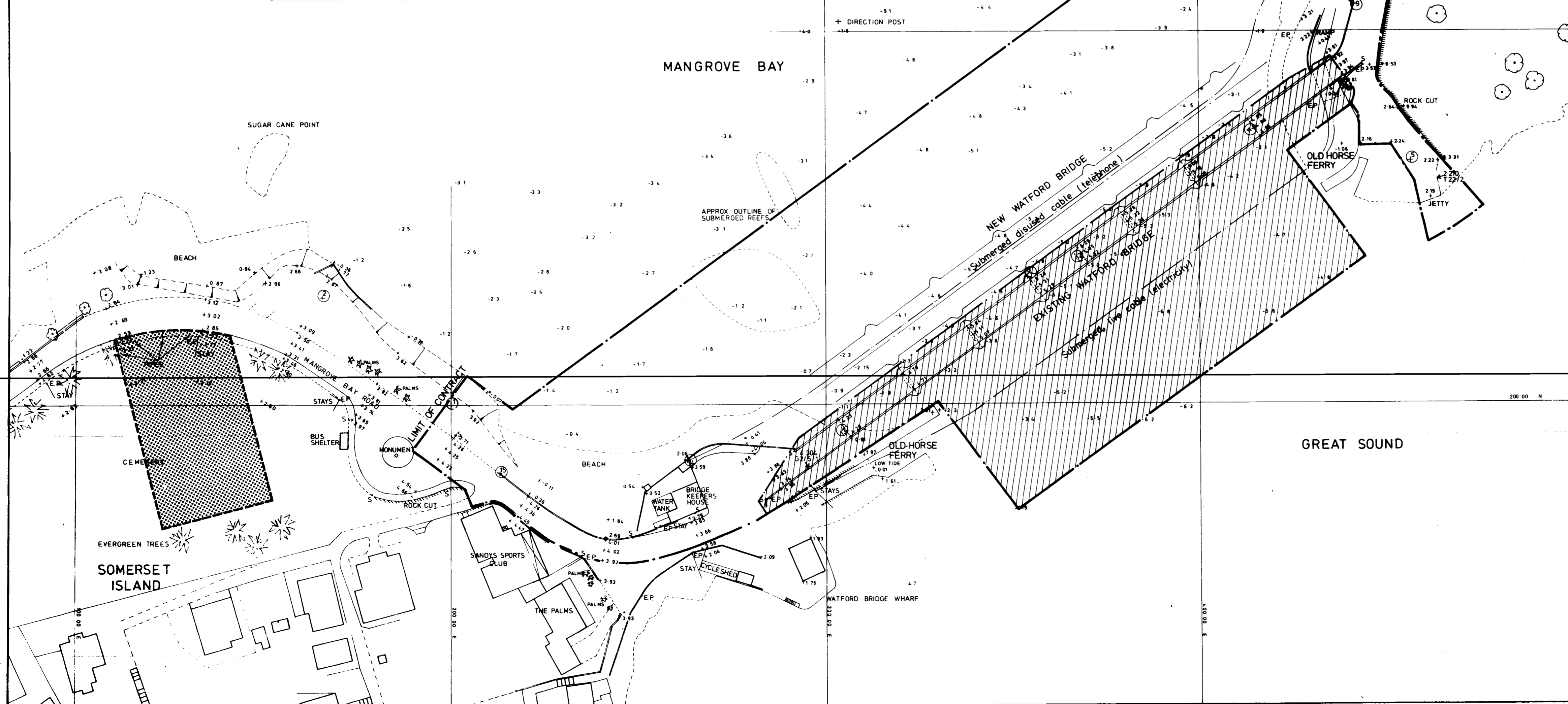

- Notes :-
1. Site limits indicated thus
 2. Possession of area shown thus within site limits will not be given to the Contractor until after diversion of traffic onto new bridge.
 3. Available Contractor's working area shown thus to be fenced with 18m high chain link or similar.
 4. This drawing is based on P.W.D. Survey and Ordnance Survey Sheets 1/8 and 1/15 of Series E 8111 (Bda 111).
 5. All levels and soundings are in metres relative to Ordnance Datum (0.000 m). Bench Mark number and height :- \leftarrow T 22/2 2.210
 6. E.P. indicates electricity pole
S indicates traffic sign
 7. Position of submerged cables indicative only
 8. This drawing to be read in conjunction with the following drawings :- 7722/3/4 - General Arrangement.

REV.	DESCRIPTION	DATE	CHECKED
GOVERNMENT OF BERMU DA			
NEW WATFORD BRIDGE			
SITE PLAN			
PUBLIC WORKS DEPT. HAMILTON 5 BERMUDA		G. MALNSELL & PARTNERS CONSULTING ENGINEERS LONDON S.E. 20.	
SCALE: 1:500 1:2500	DATE: MAY 1979		DRG. NO. 7722/3/1

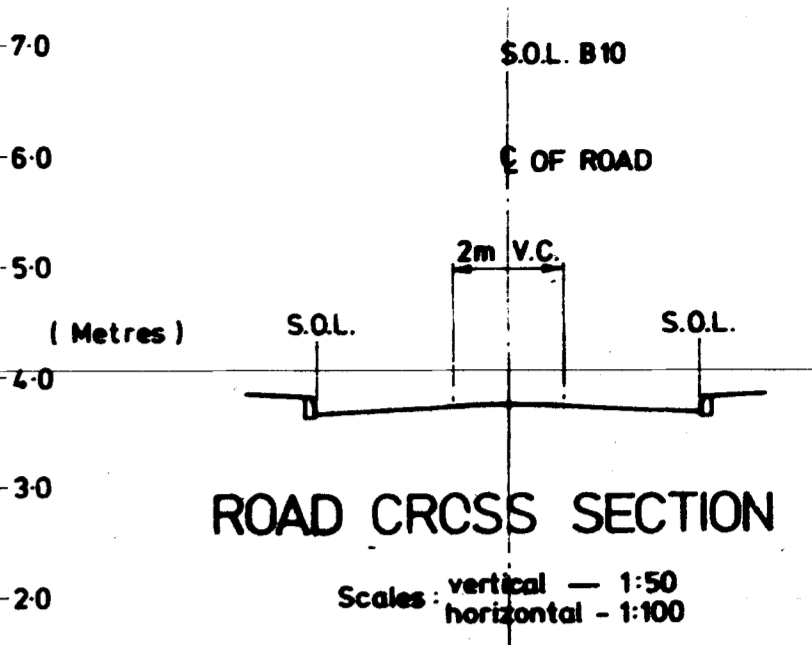
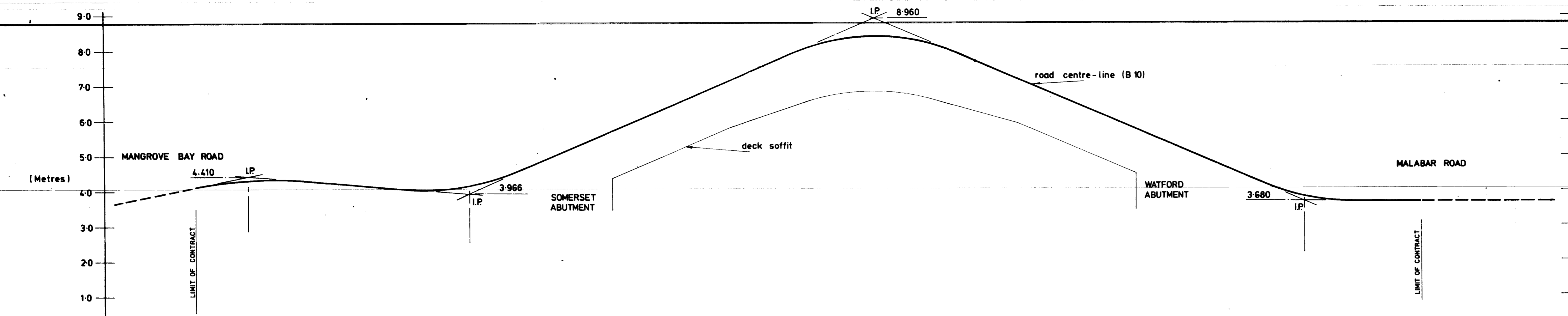

DATUM 0-000 M.S.L.														
CHAINAGE (B 10)		0+000	1+000	7+400	10+000	19+537	20+000	200+000	200+000	377+322	380+000			
HORIZONTAL ALIGNMENT		EXISTING	B 1001	B 1002	B 1003	STRAIGHT			B 1004	B 1005	B 1006	STRAIGHT	EXISTING	
VERTICAL ALIGNMENT		EXISTING	V.C. 30m	-0.70%	V.C. 30m	+4.30%			V.C. 50m	-4.30%	V.C. 30m	LEVEL	EXISTING	
CROSSFALL	LEFT	EXISTING	SMOOTH INTO EXISTING	VARIES	↑ 1 in 17.2	VARIES	↑ 1 in 40			VARIES	↑ 1 in 17.2	VARIES	SMOOTH INTO EXISTING	EXISTING
	RIGHT	EXISTING	EXISTING	VARIES	↑ 1 in 17.2	VARIES	↓ 1 in 40			VARIES	↑ 1 in 17.2	VARIES	EXISTING	EXISTING

LONGITUDINAL SECTION ON ROAD CENTRE-LINE
Scales: vertical - 1:50
horizontal - 1:500

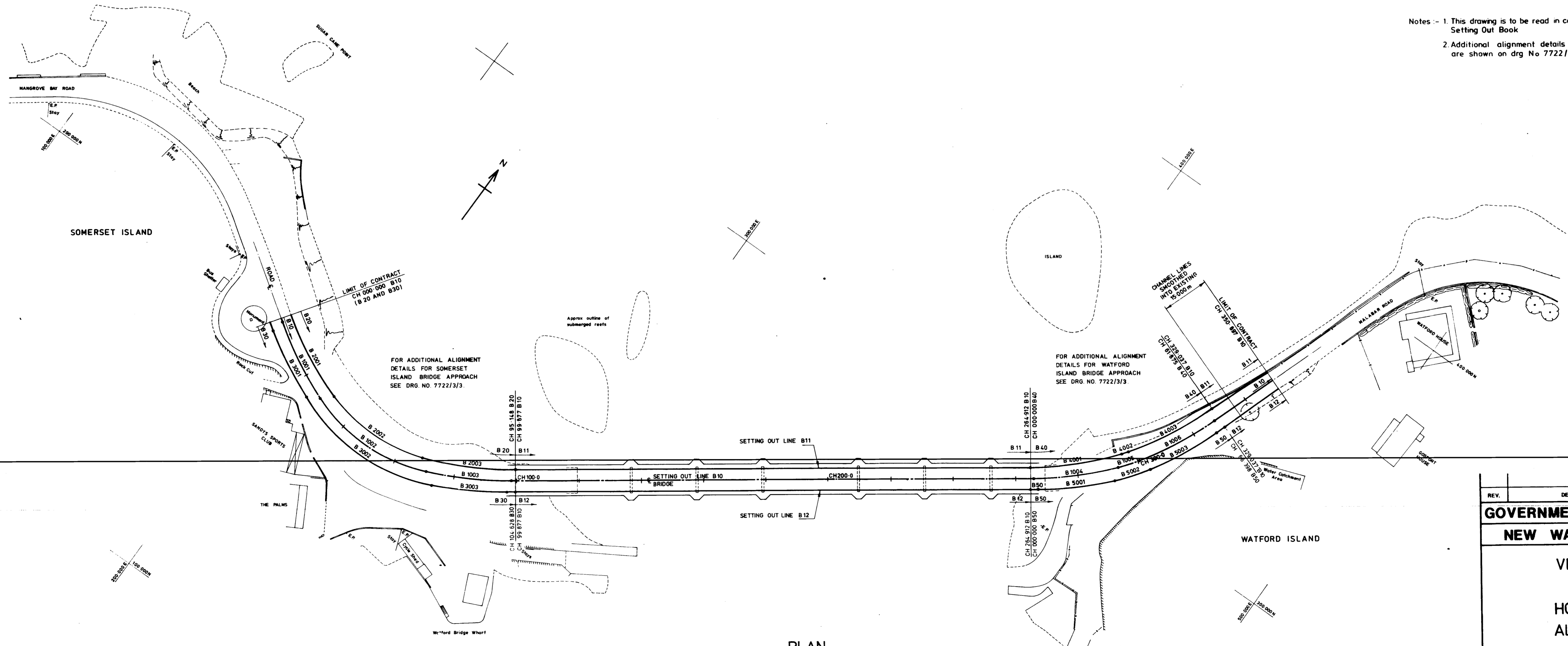

Notes:- 1. This drawing is to be read in conjunction with the Setting Out Book
2. Additional alignment details for bridge approaches are shown on drg No 7722/3/3

PLAN
Scale: 1:500

REV.	DESCRIPTION	DATE	CHECKED
GOVERNMENT OF BERMUDA			
NEW WATFORD BRIDGE			
VERTICAL AND HORIZONTAL ALIGNMENTS			
PUBLIC WORKS DEPT. HAMILTON 5 BERMUDA		G. MAUNSELL & PARTNERS CONSULTING ENGINEERS LONDON S.E. 20.	
SCALE: AS SHOWN		DRG. NO. 7722/3/2.	
DATE: MAY 1979	DRAWN BY: G.J.H.		

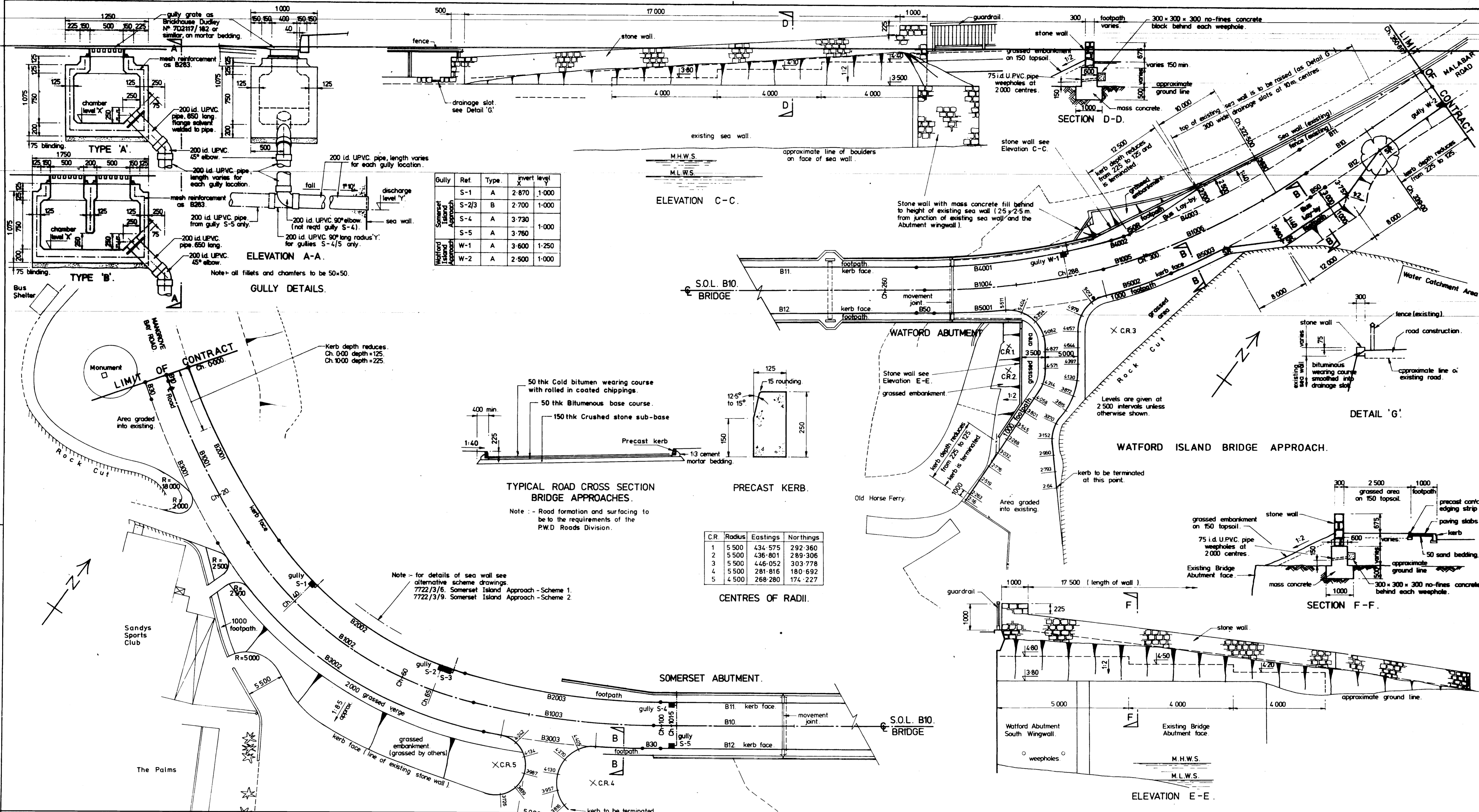

- Notes -
- All dimensions are in millimetres.
 - Levels are given to Datum 0.00 at Mean Sea Level.
 - Surface finishes - denoted on drawing thus (F2) formed surfaces to be F1 unless otherwise noted. unformed surfaces to be U1 unless otherwise noted.
 - Concrete class -
Class 22-5/20 mass concrete, gully chambers, bases and upstands for walls.
 - Reinforcement - gully chambers, mesh reinforcement as B283, cover - mesh placed at mid-depth, as indicated.
 - This drawing to be read in conjunction with the following -
7722/3/2. Vertical and Horizontal Alignment (and the Setting Out Book.)
7722/3/6. Somerset Island Approach - Scheme 1.
7722/3/9. Somerset Island Approach - Scheme 2.

REV.	DESCRIPTION	DATE	CHECKED
GOVERNMENT OF BERMUDA			
NEW WATFORD BRIDGE			
LAYOUT OF BRIDGE APPROACHES			
PUBLIC WORKS DEPT. HAMILTON 5 BERMUDA		G. MAUNSELL & PARTNERS CONSULTING ENGINEERS LONDON S.E. 20.	
SCALE: 1:20 1:50 1:200	DRG. NO. 7722/3/3		
DATE: MAY 1979	DRAWN BY: N.A.R.		

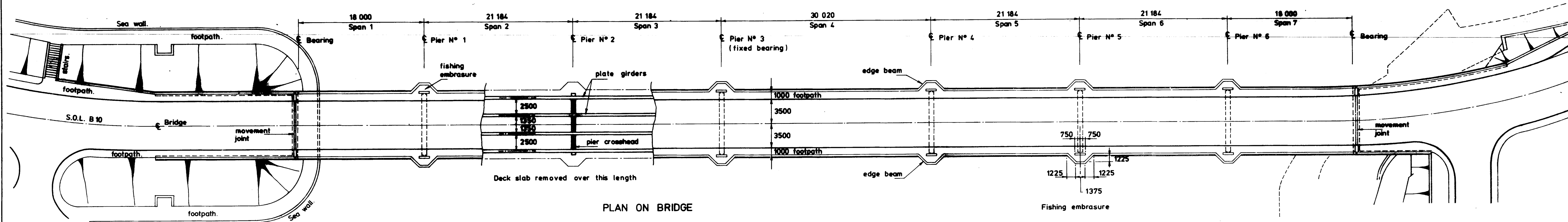
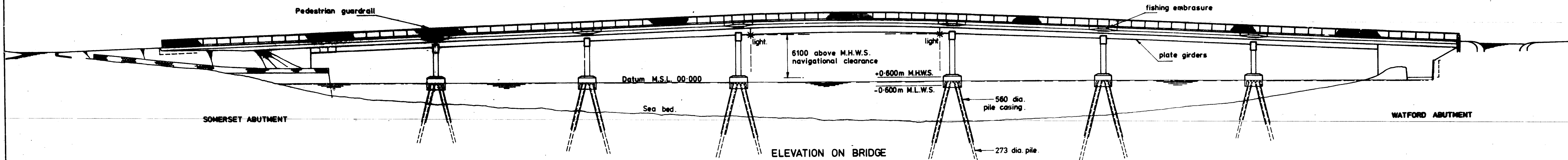

Note:- Somerset Abutment / Island Approach.
 Scheme 1 - as shown on Elevation and Plan.
 Scheme 2 - face of Abutment as shown.
 - there is no Sea wall or embankment.
 - for detail see drawing 7722/3/9.

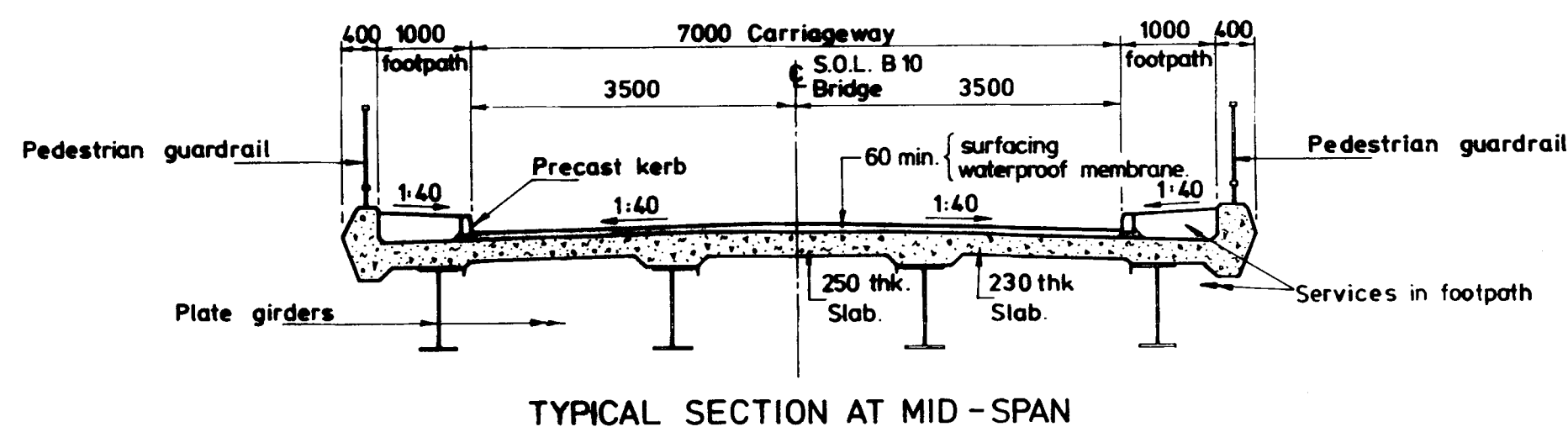

- Notes:-
 1. All dimensions are in millimetres.
 2. Levels are given to Datum 0000 of Mean Sea Level.
 3. This drawing to be read in conjunction with the following drawings:-
 7722/3/1 - Site Plan.
 7722/3/2 - Vertical and Horizontal Alignment (and the Setting Out Book)
 7722/3/3 - Layout of Bridge Approaches.

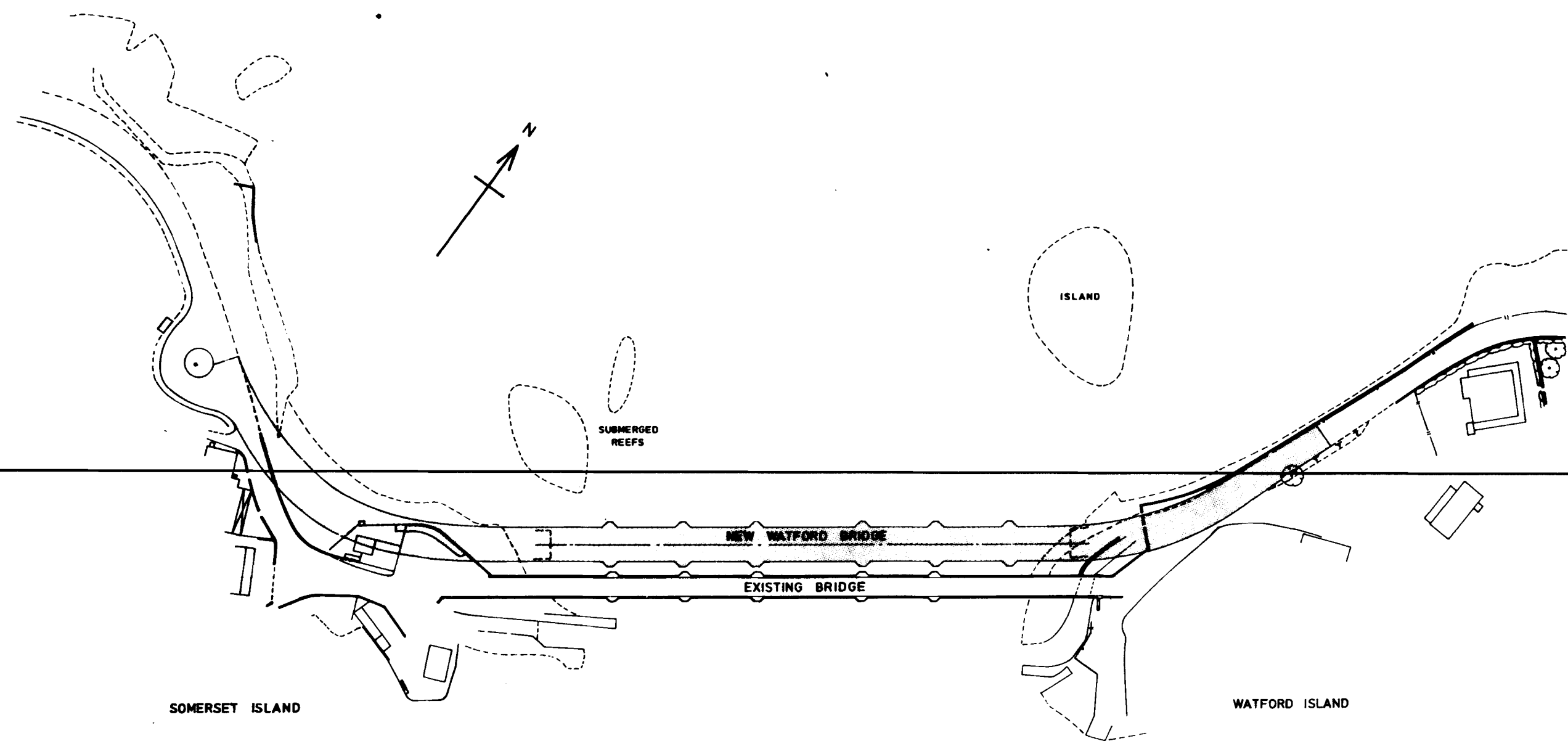
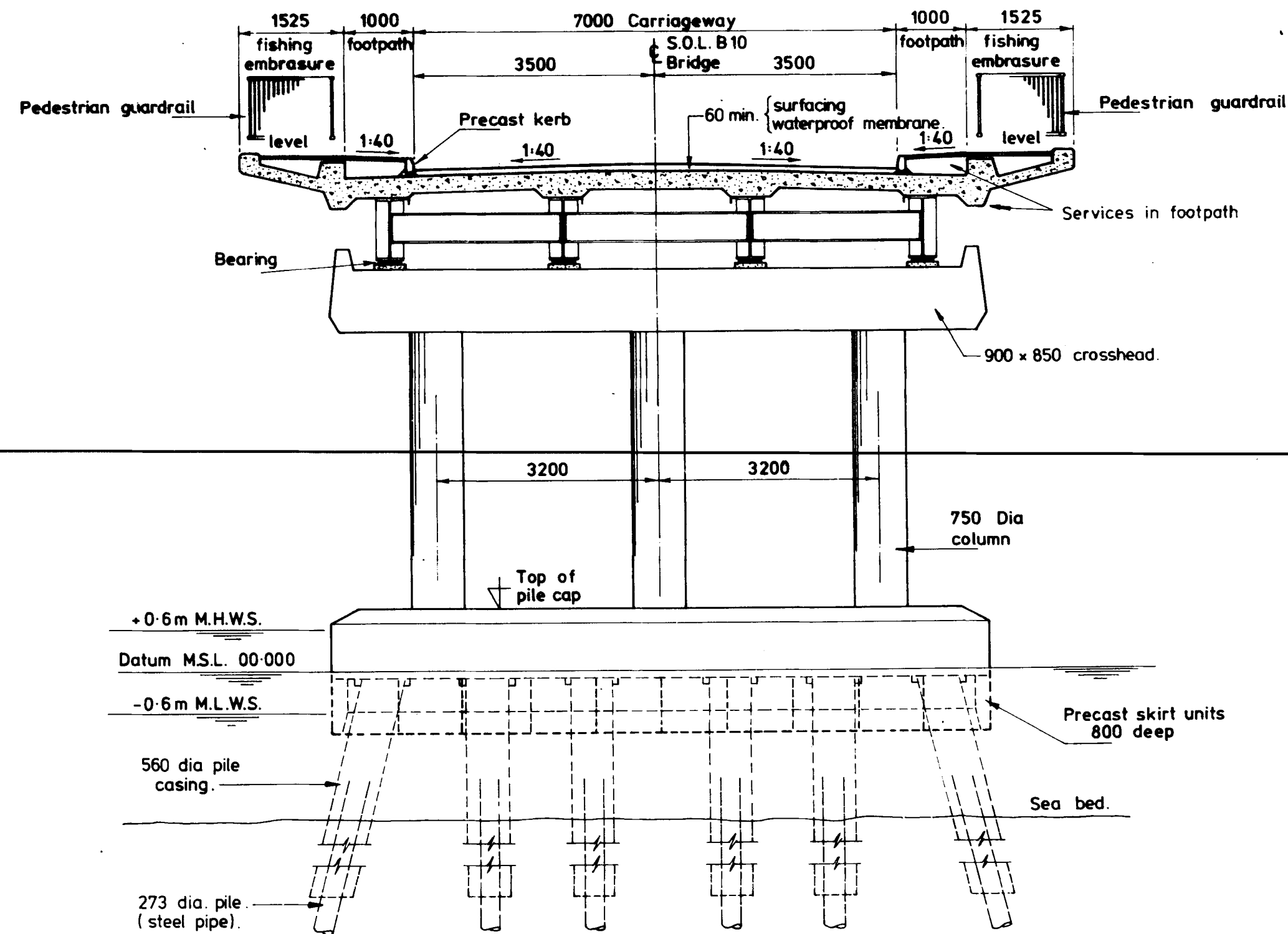

LOCATION PLAN.

NOTE: Shaded area gives only indication of location of new works and does not show full extent of new works.
 Existing Bridge to be demolished after completion of the new bridge.

REV.	DESCRIPTION	DATE	CHECKED
GOVERNMENT OF BERMUDA			
NEW WATFORD BRIDGE			
GENERAL ARRANGEMENT.			
PUBLIC WORKS DEPT. HAMILTON 5 BERMUDA		G. MAUNSELL & PARTNERS CONSULTING ENGINEERS LONDON S.E. 20.	
SCALE: 1:1000 1:200 1:50		DRG. NO. 7722/3/4	
DATE: MAY 1979.		DRAWN BY: G.J.H.	

TYPICAL VIEW ON PIER

BAR LOCATING TABLE				
Bending Schedule N° 2351				
Bar No.	Grouping	Shape	Cr. No.	Estab. No.
PILES				
PIER NO 1 (1 00)				
6 01 Y	12 x 11	11	65	500 138
12 02 Y	12 x 8	8	20	96
PIER NO 2				
6 01 Y	12 x 13	13	65	500 156
12 03 Y	12 x 8	8	20	96
PIER NO 3				
6 01 Y	18 x 18	18	65	500 196
12 04 Y	18 x 8	8	20	112
PIER NO 4				
6 01 Y	18 x 16	16	65	500 204
12 05 Y	18 x 8	8	20	112
PIER NO 5				
6 01 Y	12 x 15	15	65	500 180
12 06 Y	12 x 8	8	20	96
PIER NO 6				
6 01 Y	12 x 10	10	65	500 120
12 07 Y	12 x 8	8	20	96

KEY
 ● BH - Boreholes 1978-1979 soil survey
 ▣ TP - Trial pit 1978-1979 soil survey

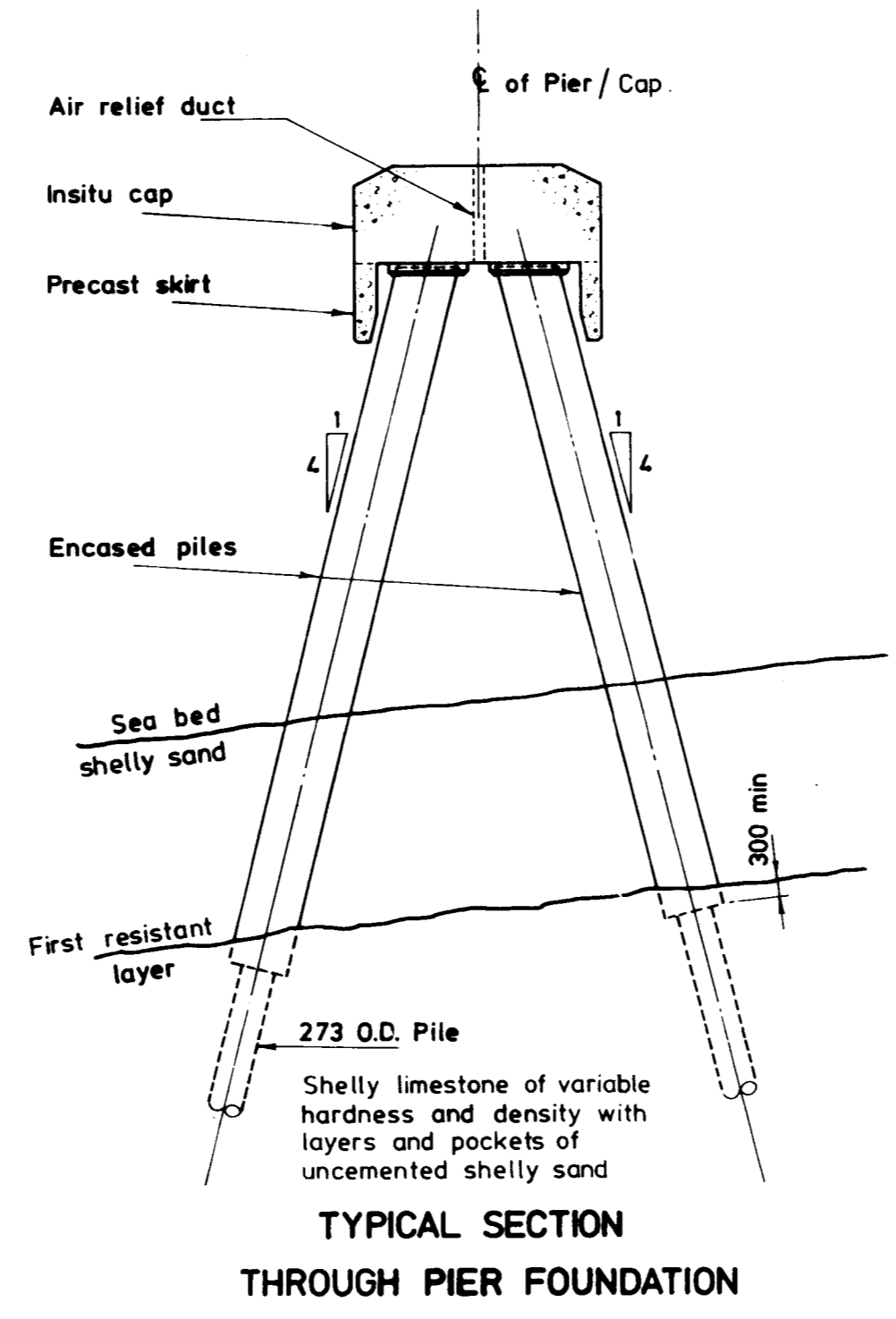
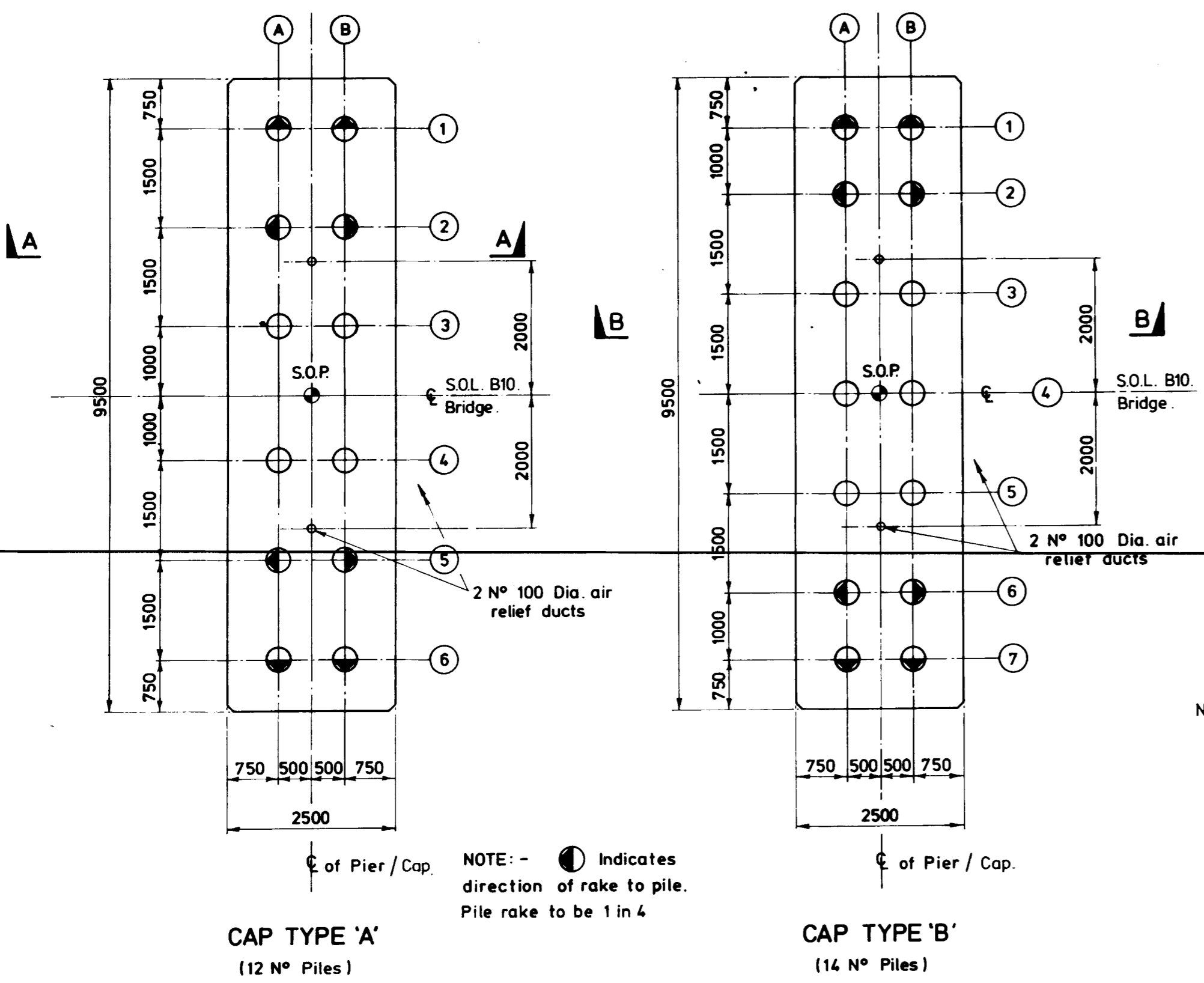
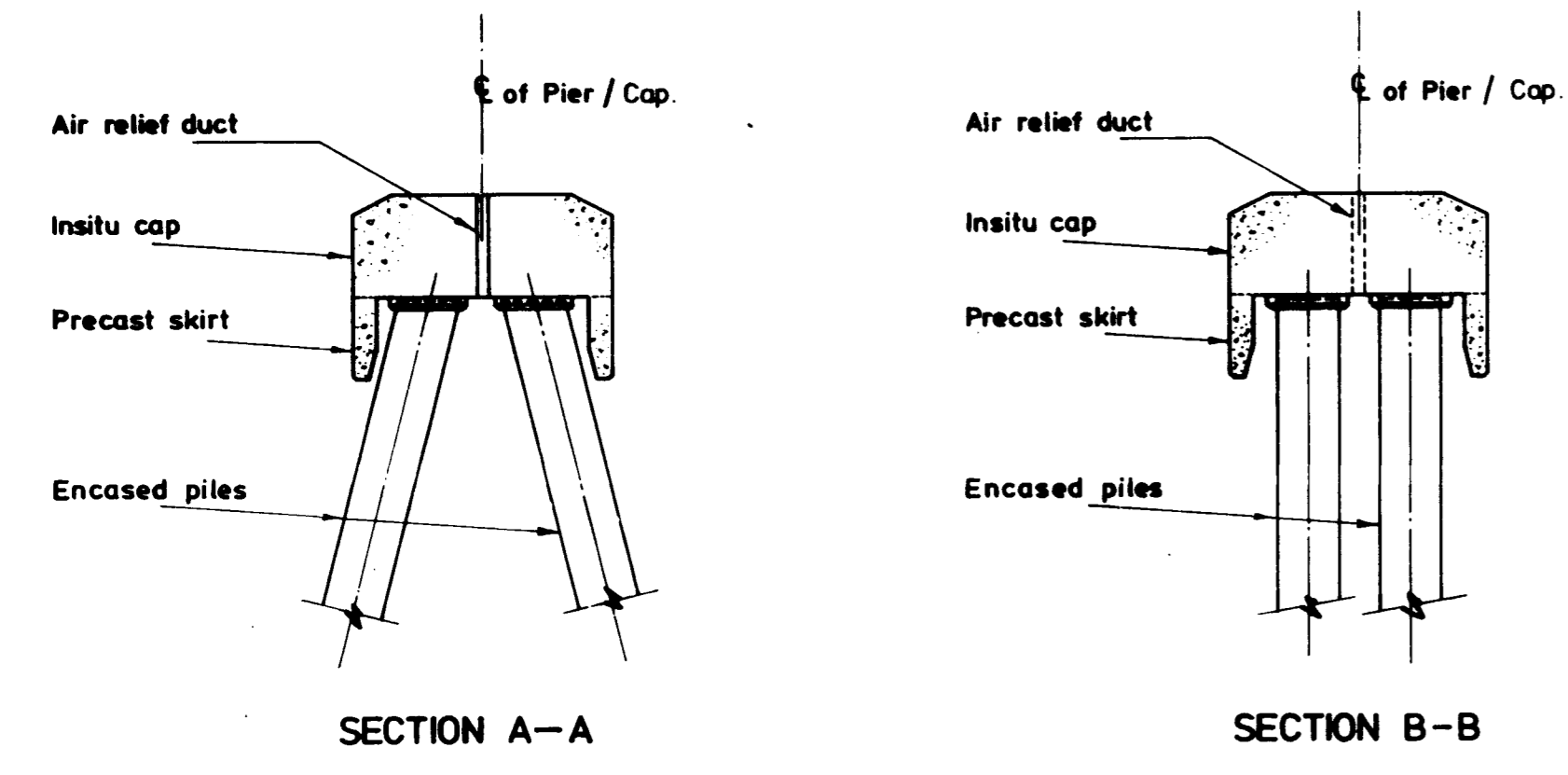
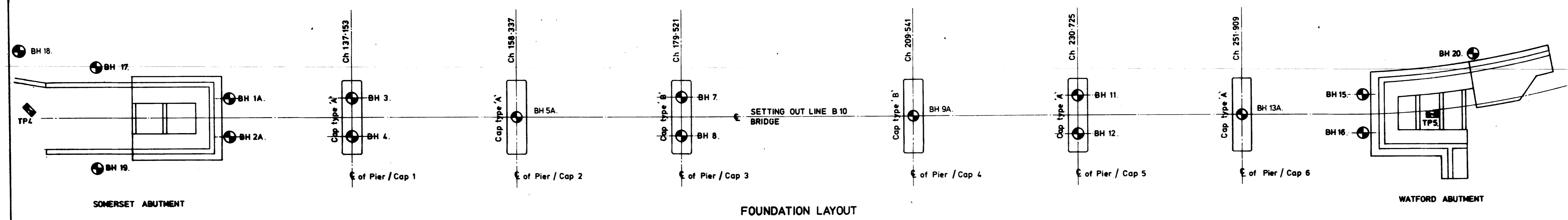

Cap No.	bars 'a'
1	12 02 Y
2	12 03 Y
3	12 04 Y
4	12 05 Y
5	12 06 Y
6	12 07 Y

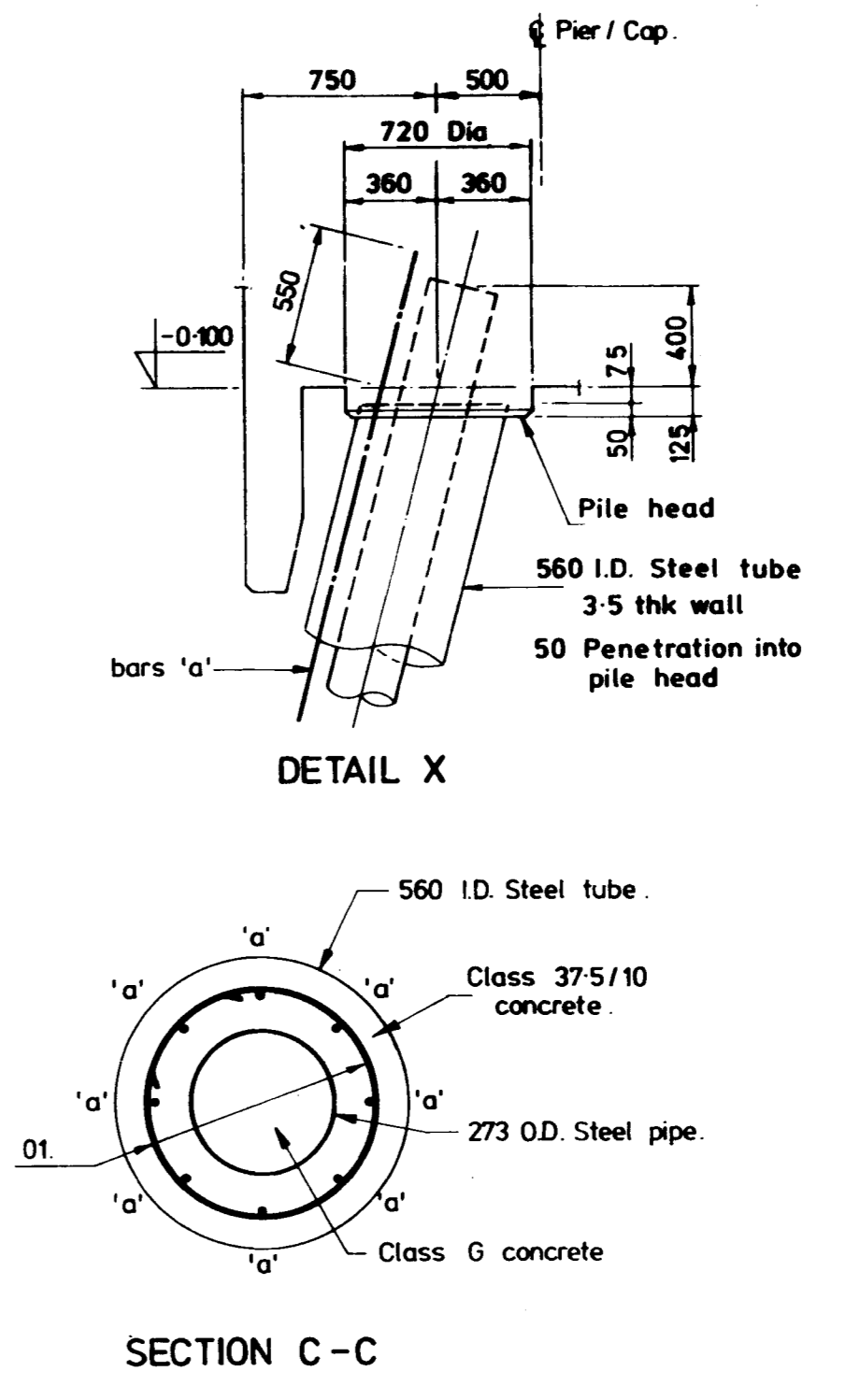
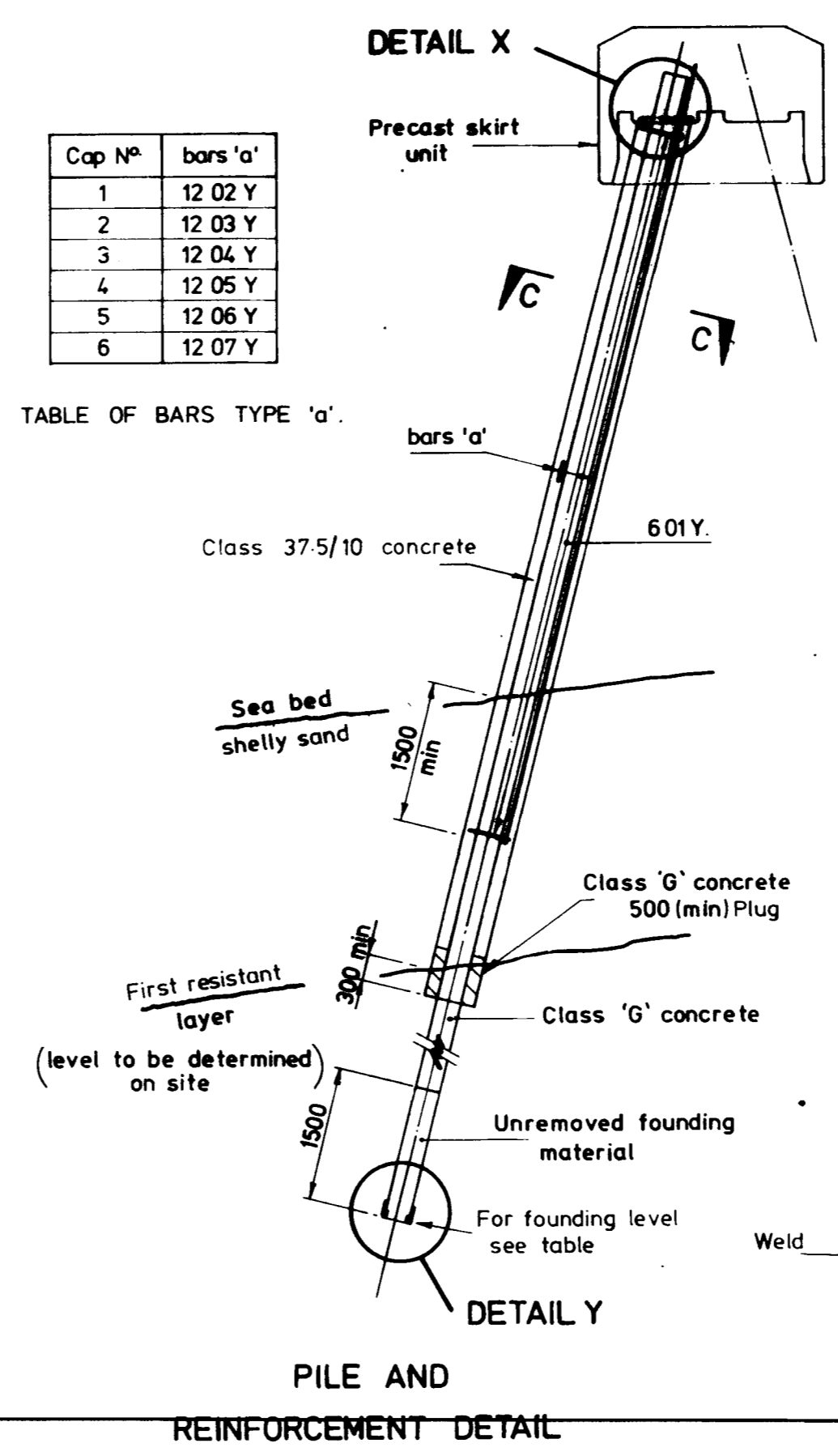

- Note:-
- All dimensions are in millimetres.
 - Levels are to Datum 0000 at Mean Sea Level.
 - Concrete classes:-
 class 37.5/10 - pile casing.
 class 'G' - in pile.
 - Reinforcement:-
 a) all reinforcement to be high yield deformed bars to BS 4449 and galvanised in accordance with BS 729, see Specification Clause 1506. High yield bars are shown as type Y.
 b) bar mk.
 12 03 Y bar type.
 reference number.
 bar diameter.
 - Bending Schedule N° 2351, as shown at head of Bar Locating Table.
 - This drawing to be read in conjunction with the following drawings:-
 7722/3/4 - General Arrangement.
 7722/3/14 - Details of Piers.

PILE DESIGNATION

Notes:-

- Pile reference
 Cap No. — 1 A 4
 Transverse grid line letter
 Longitudinal grid line No.

2. Tolerances for the position and alignment of piles; the finished head of a pile shall be within 75 mm of position shown on drawing. The difference between the mean position of any row of piles to that shown on the drawing in either the longitudinal or transverse directions shall not exceed 25 mm.

Alignment vertical piles :- not more than 1:80 from plumb

Alignment raking piles :- not more than 1:25 from rake shown

Borehole	Reduced level (M.S.L)	
	Sea-bed	Bottom of borehole
3	-2.72	-15.37
4	-3.15	-23.39
5A	-3.96	-26.59
7	-4.65	-34.09
8	-4.78	-29.39
9A	-5.69	-31.19
11	-4.94	-26.30
12	-4.86	-26.81
13A	-2.65	-24.90

Pier / Cap	Reduced level (M.S.L)	
	First resistant layer	Minimum founding level
1	-3.7	-25.0
2	-5.2	-25.0
3	-6.2	-30.0
4	-8.2	-30.0
5	-5.2	-27.5
6	-3.2	-25.0

Note:- level of first resistant layer given in table is estimated, actual level to be determined on site. All levels are given in metres.

REV.	DESCRIPTION	DATE	CHECKED
GOVERNMENT OF BERMUDA			
NEW WATFORD BRIDGE			
FOUNDATION PLAN			
PUBLIC WORKS DEPT. HAMILTON 5 BERMUDA		G. MAUNSELL & PARTNERS CONSULTING ENGINEERS LONDON S.E. 20.	
SCALE: 1:10, 1:20, 1:50, 1:200	DATE: MAY 1979		DRG. NO. 7722/3/5

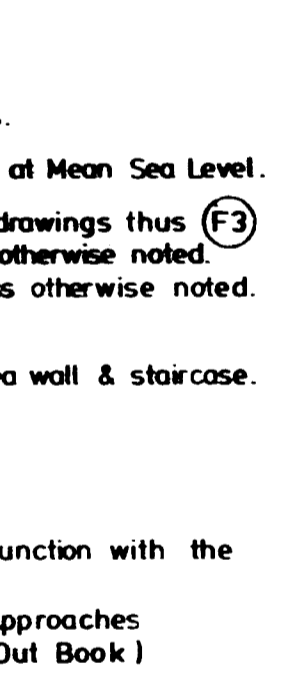
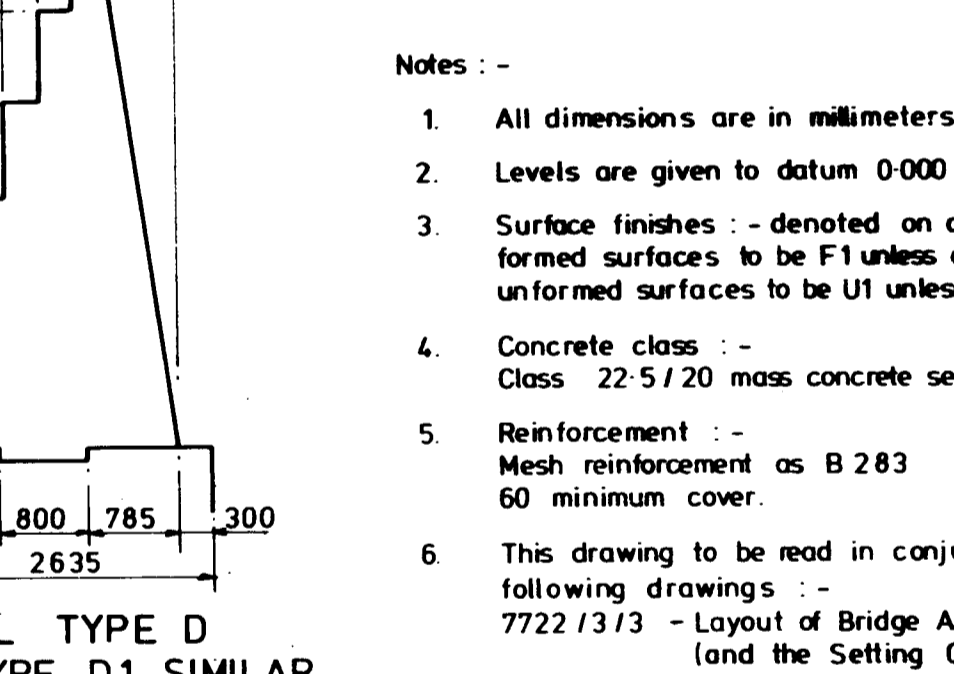
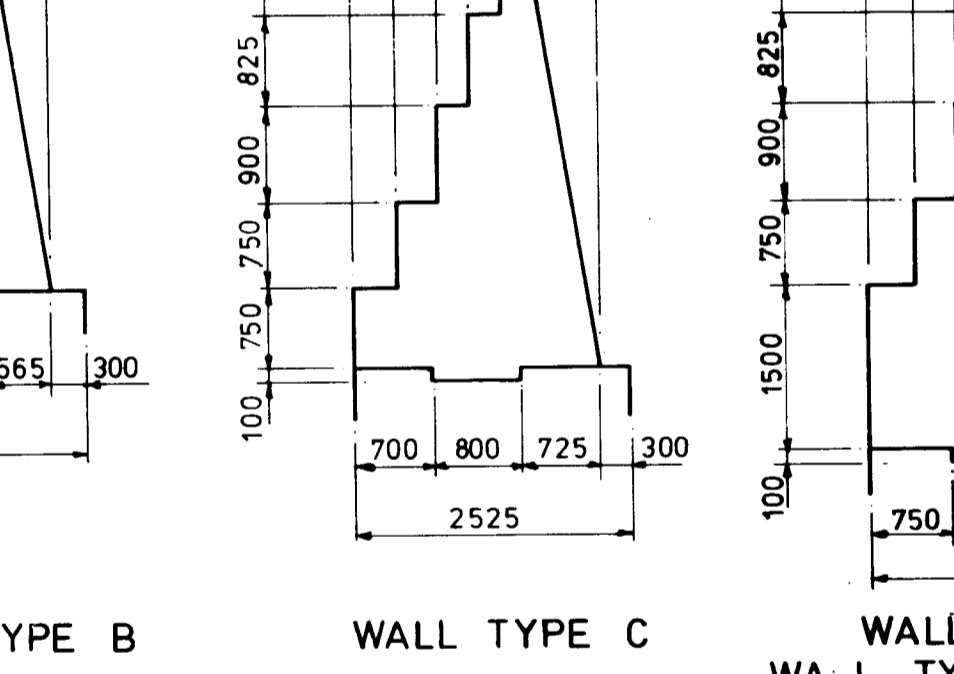
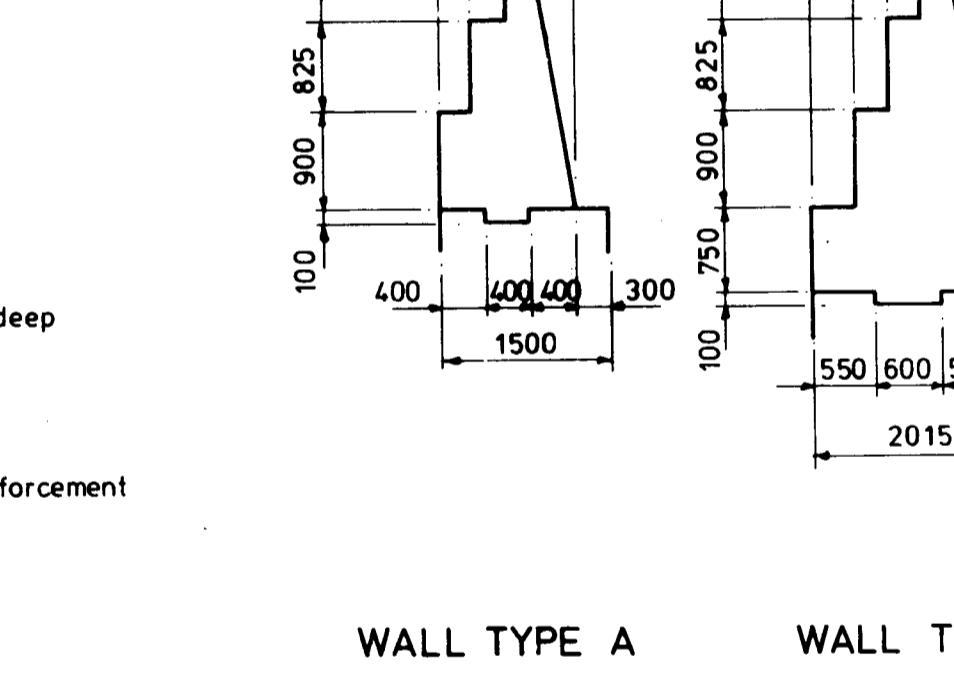
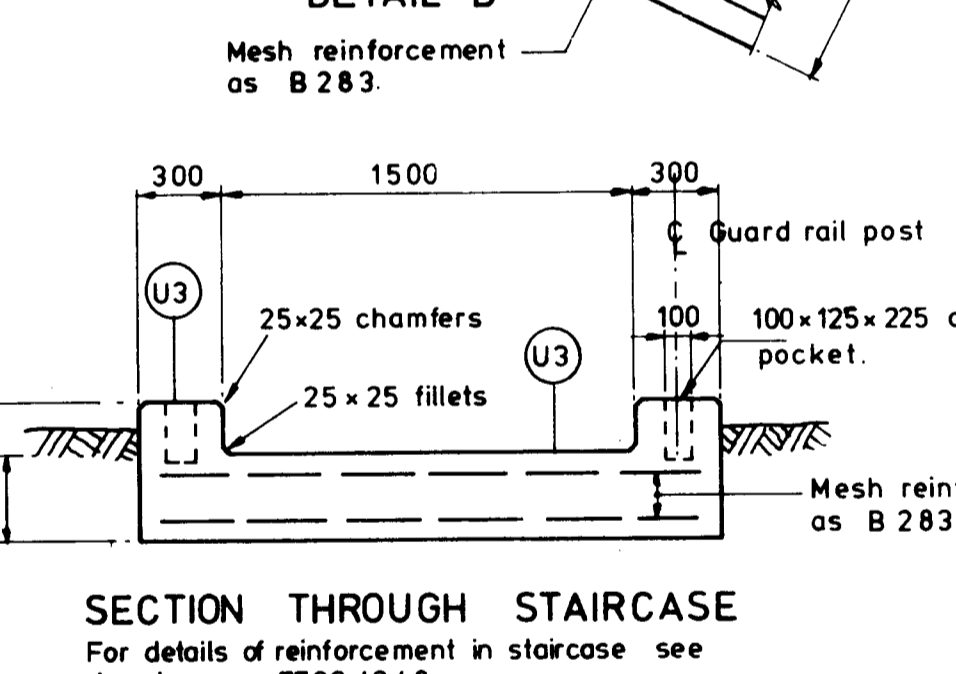
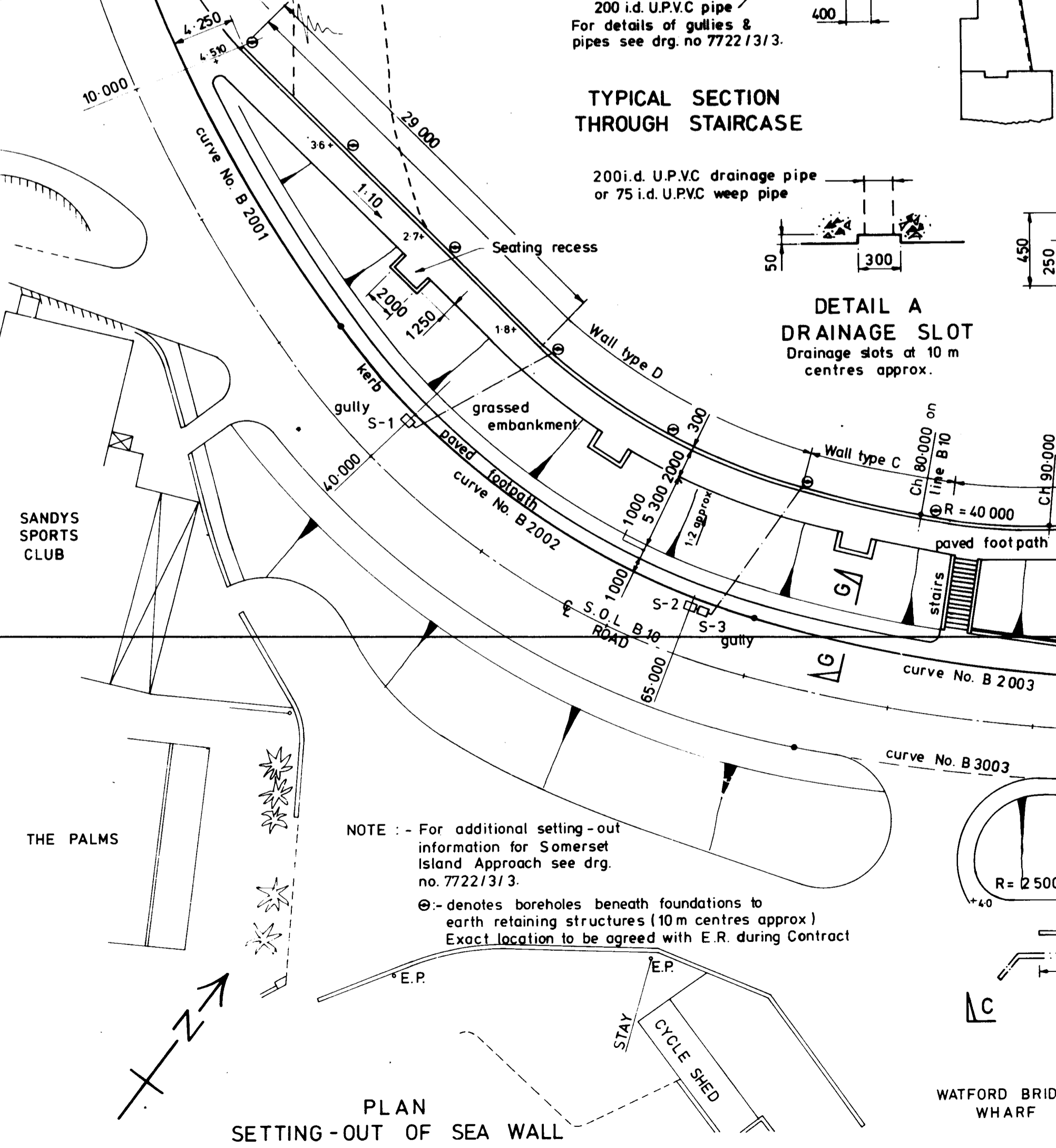
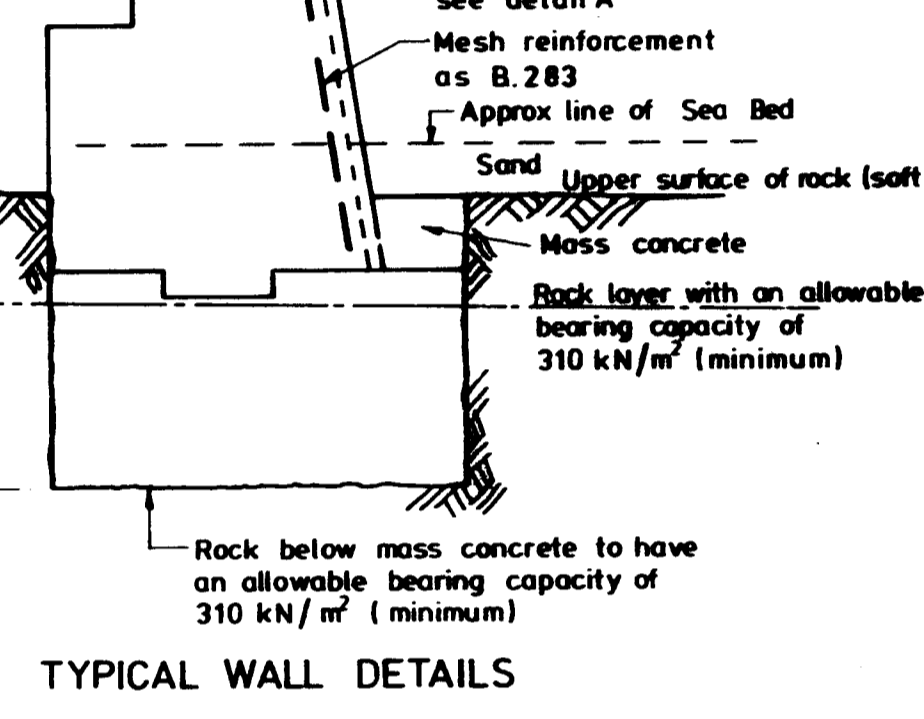
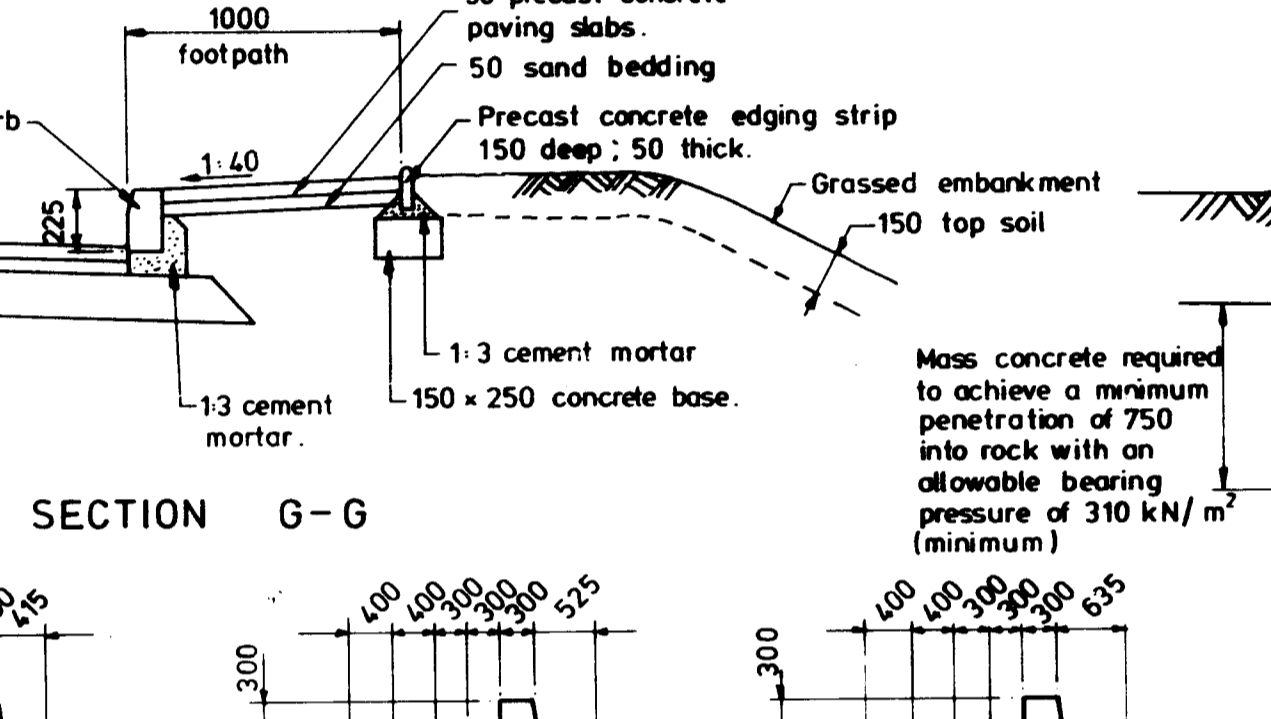
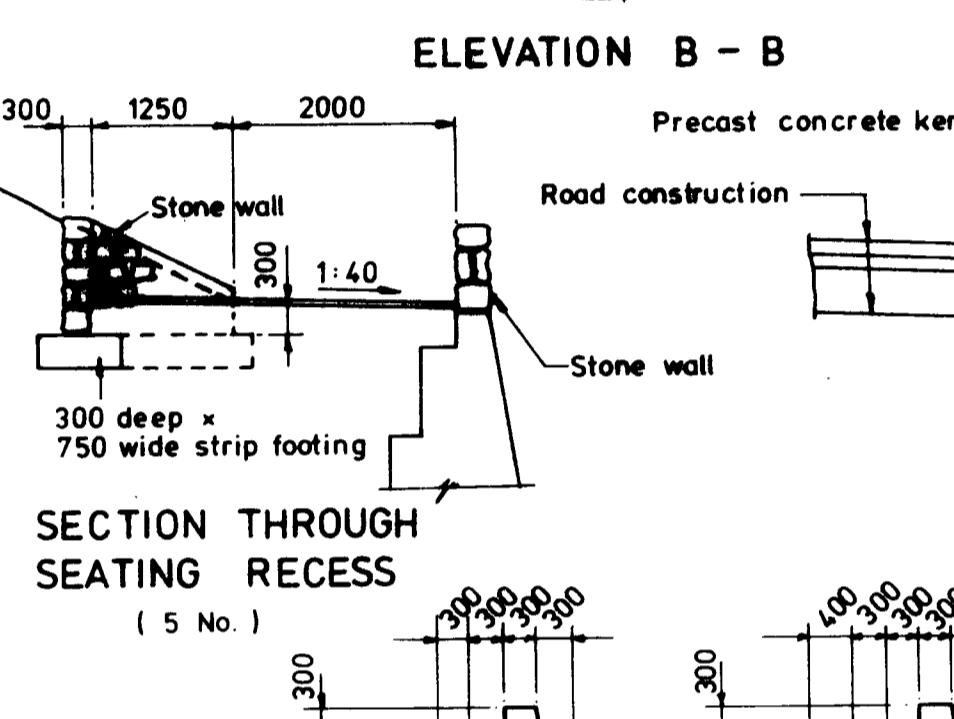
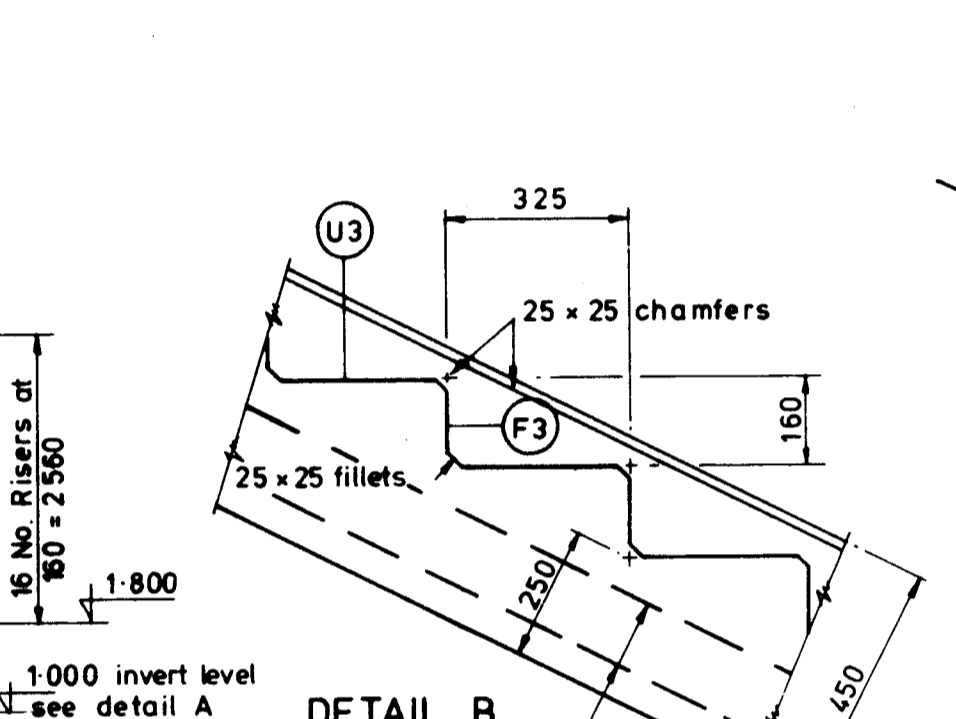
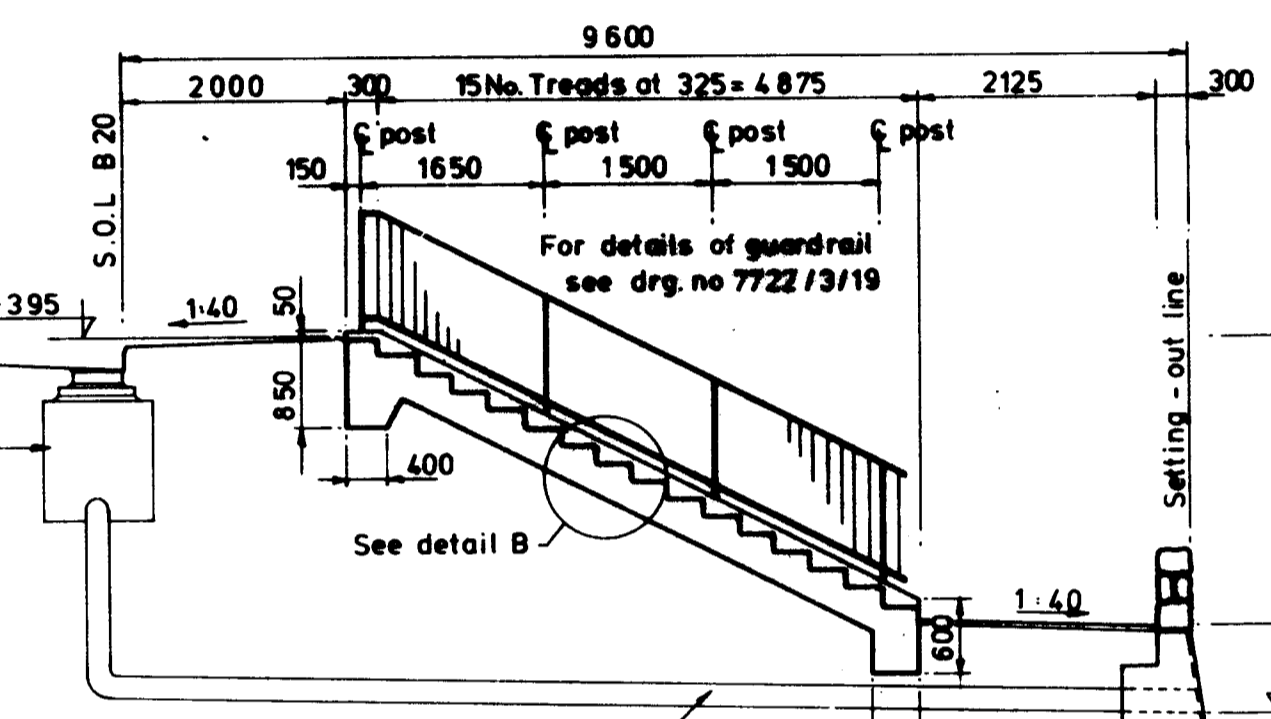
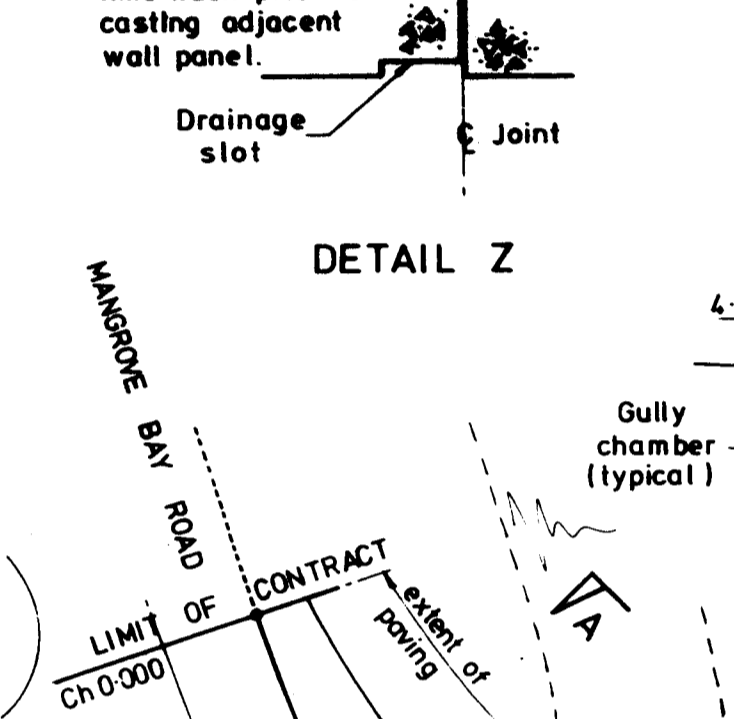
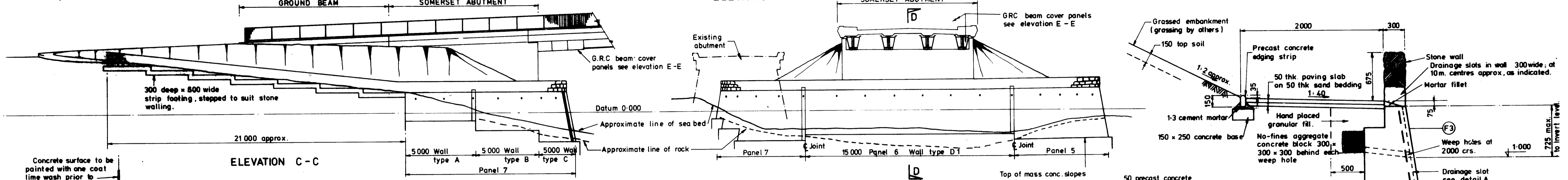
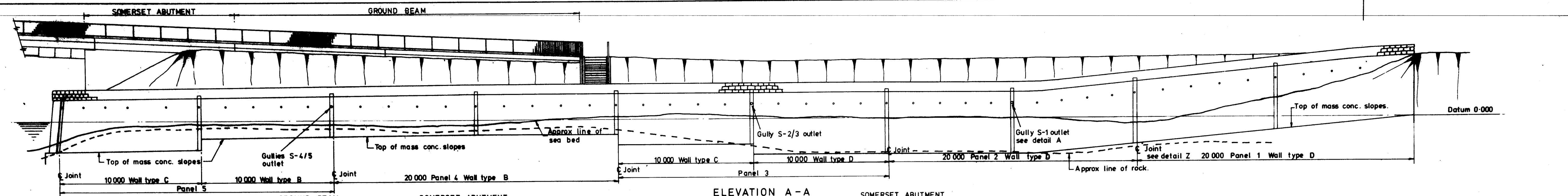

- Notes :-
- All dimensions are in millimeters.
 - Levels are given to datum 0-000 at Mean Sea Level.
 - Surface finishes :- denoted on drawings thus (F3) formed surfaces to be F1 unless otherwise noted. unformed surfaces to be U1 unless otherwise noted.
 - Concrete class :- Class 22-5/20 mass concrete sea wall & staircase.
 - Reinforcement :- Mesh reinforcement as B 283 60 minimum cover.
 - This drawing to be read in conjunction with the following drawings :- 7722/13/3 - Layout of Bridge Approaches (and the Setting Out Book) 7722/13/7 - Somerset Abutment G.A. Scheme 1. 7722/13/8 - Somerset Abutment R.C. Details Scheme 1.

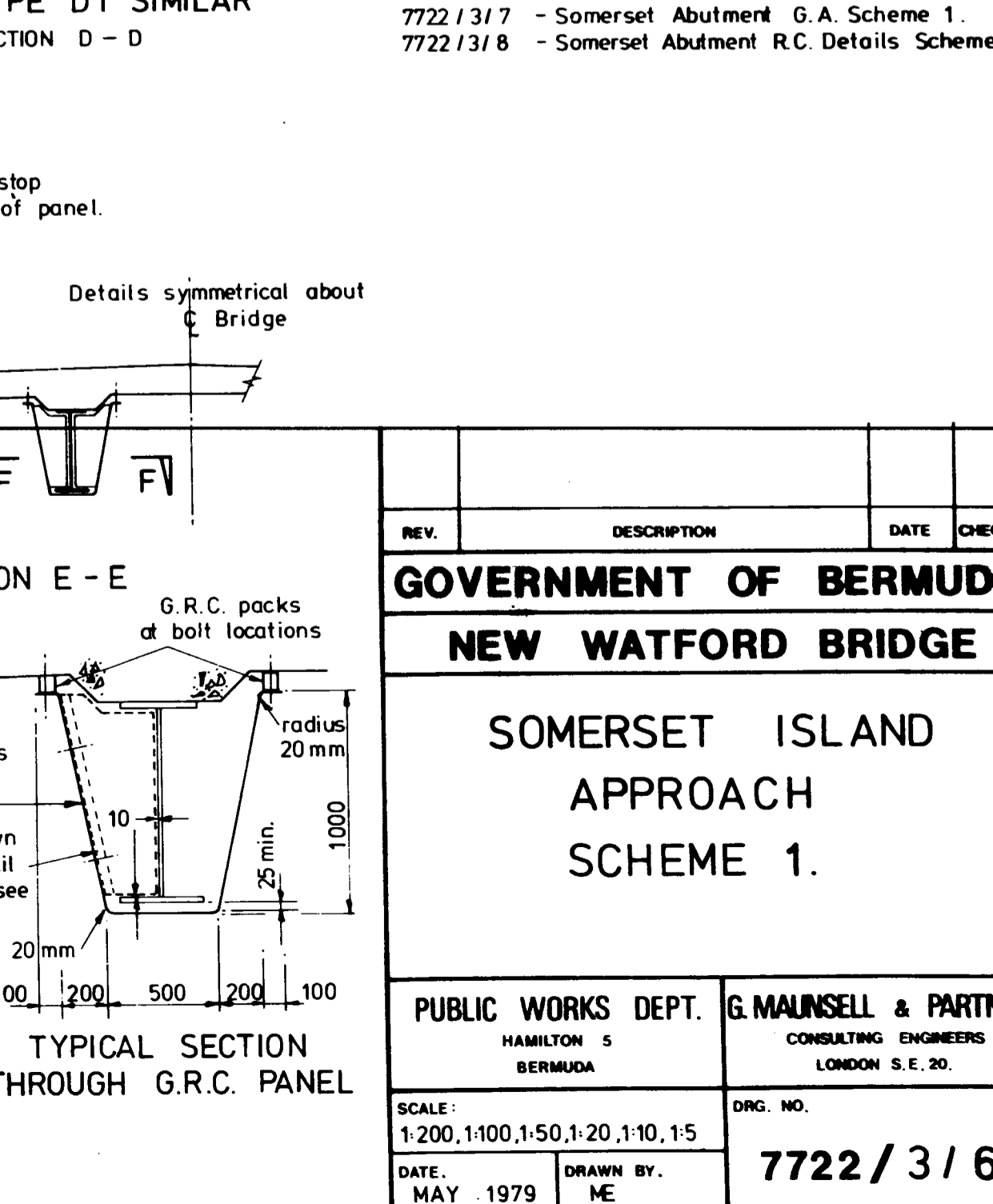
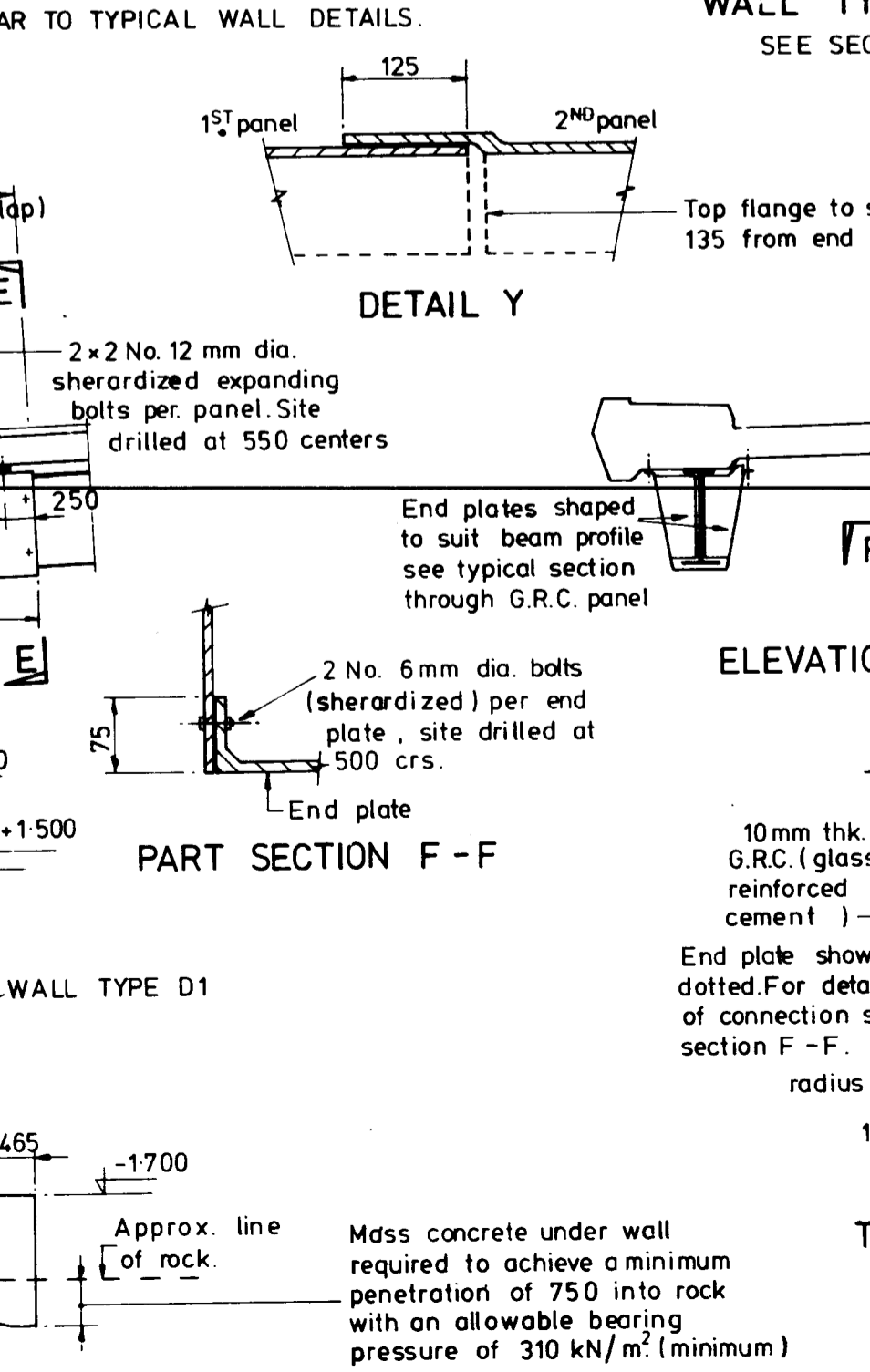
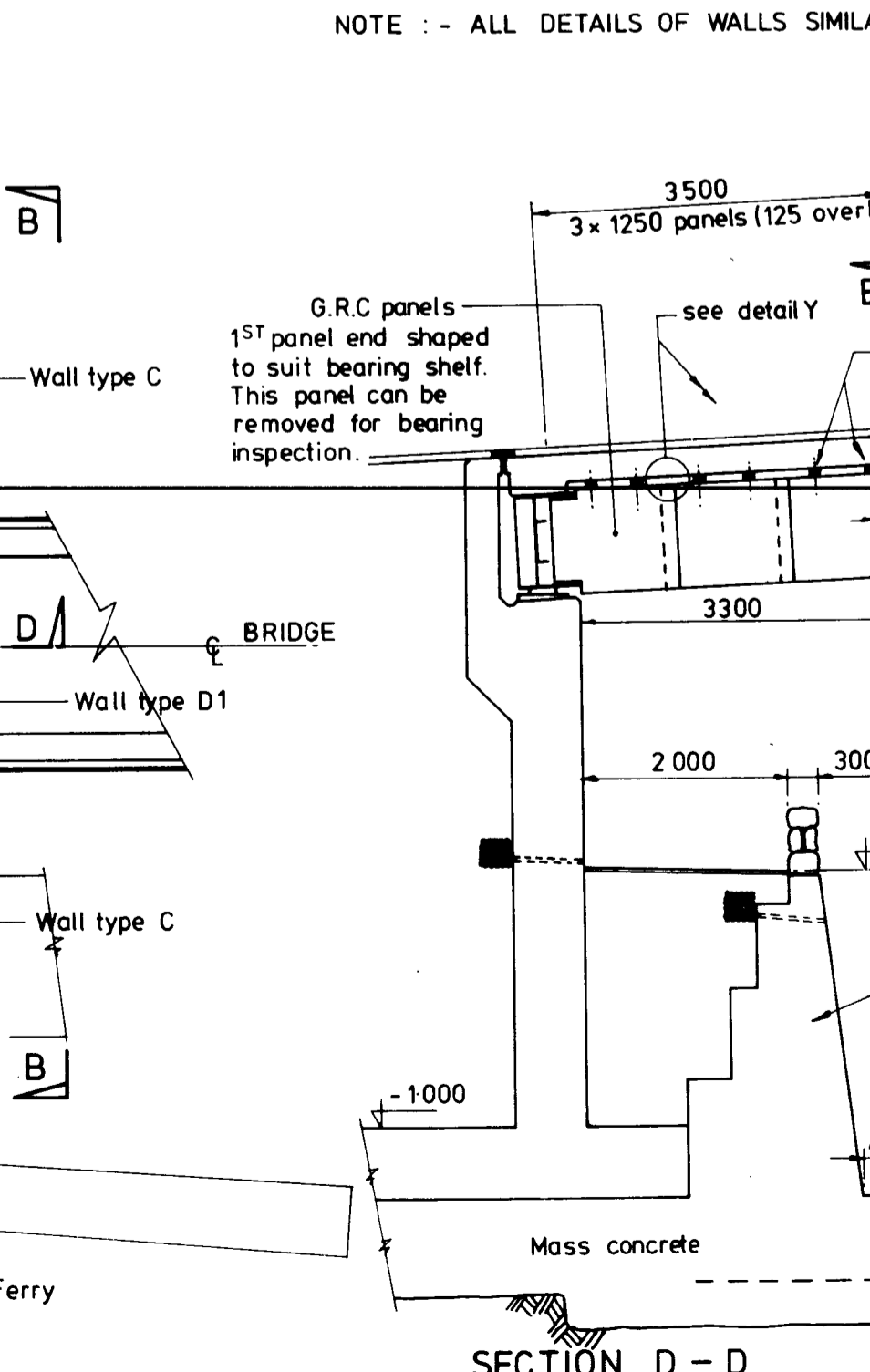
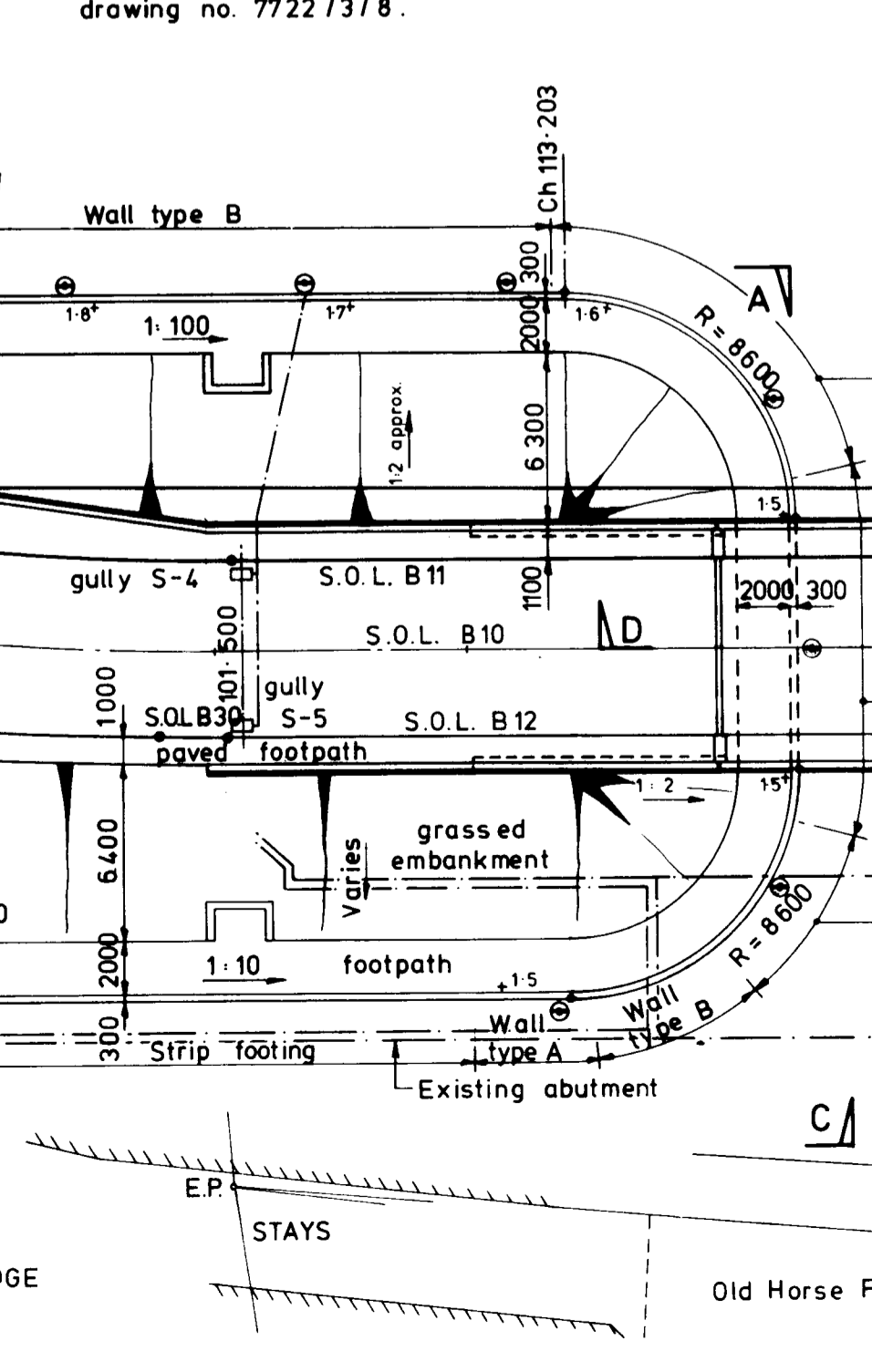

REV.	DESCRIPTION	DATE	CHECKED
GOVERNMENT OF BERMUDA			
NEW WATFORD BRIDGE			
SOMERSET ISLAND APPROACH SCHEME 1.			
PUBLIC WORKS DEPT. HAMILTON 5 BERMUDA		G. MAUNSELL & PARTNERS CONSULTING ENGINEERS LONDON S.E. 20.	
SCALE: 1:200, 1:100, 1:50, 1:20, 1:10, 1:5		DRG. NO. 7722/3/6	
DATE: MAY 1979	DRAWN BY: ME		

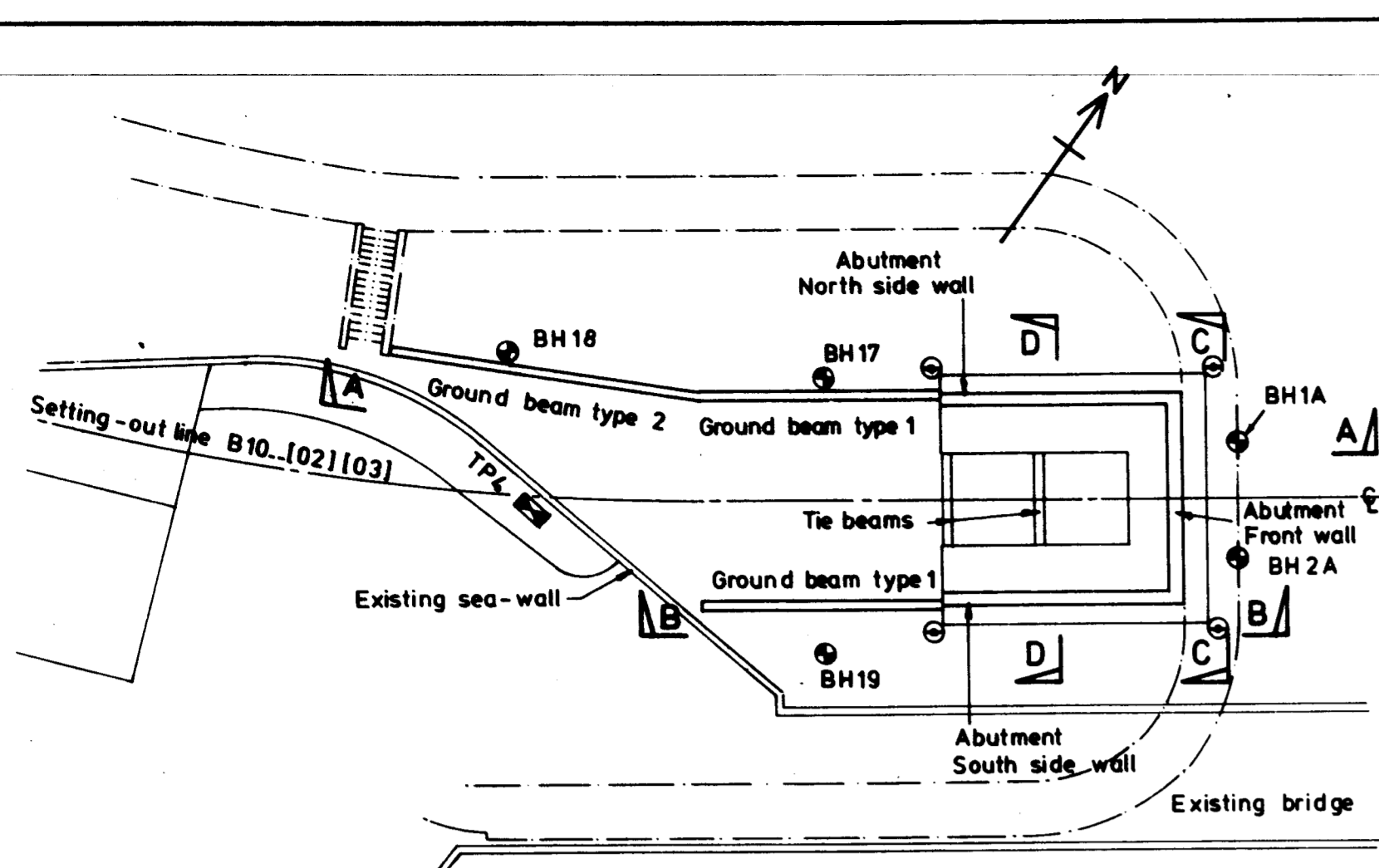

KEY PLAN ⊙ - Denotes boreholes beneath foundations to earth retaining structures. Exact location to be agreed with E.R during Contract.

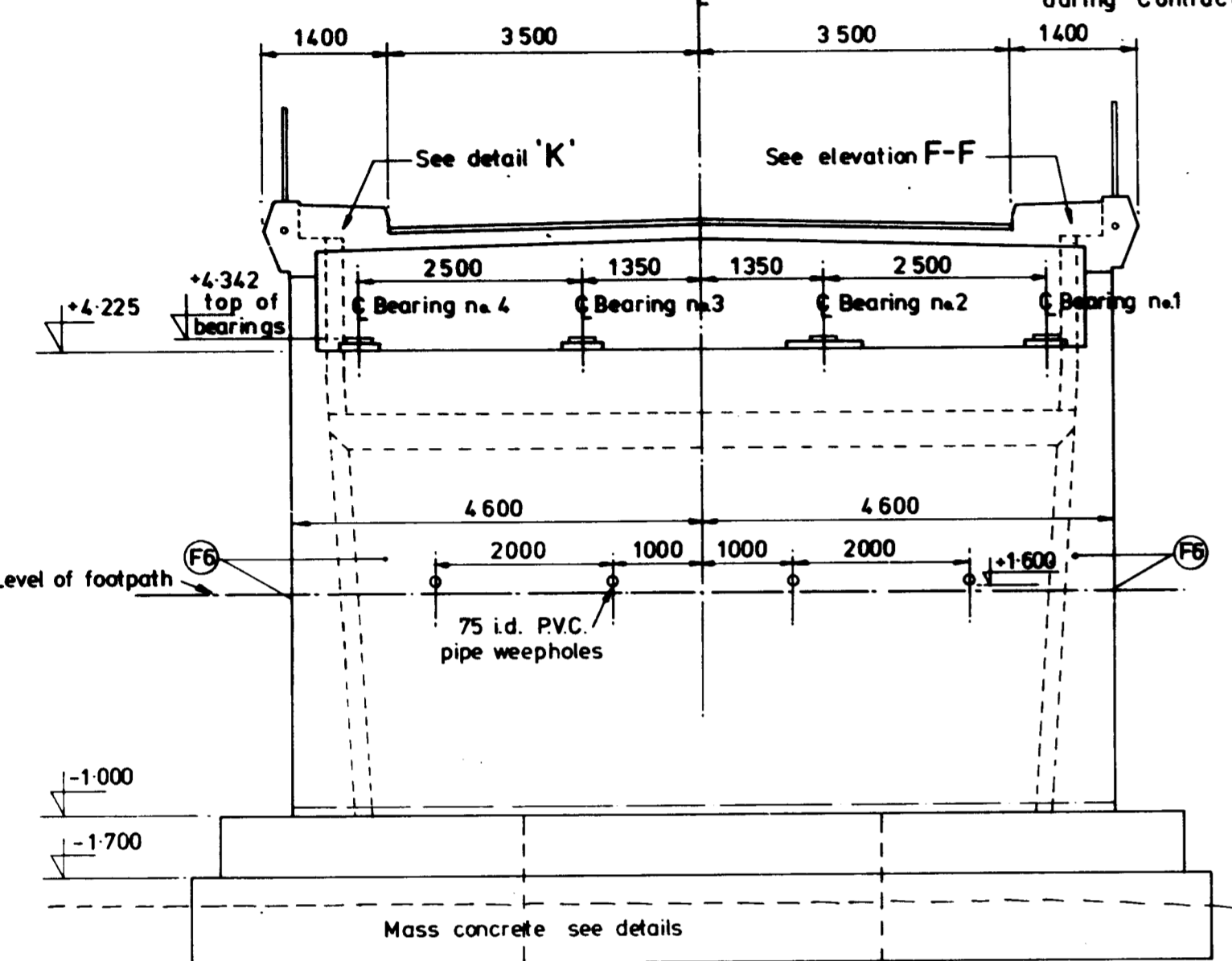

ELEVATION C-C

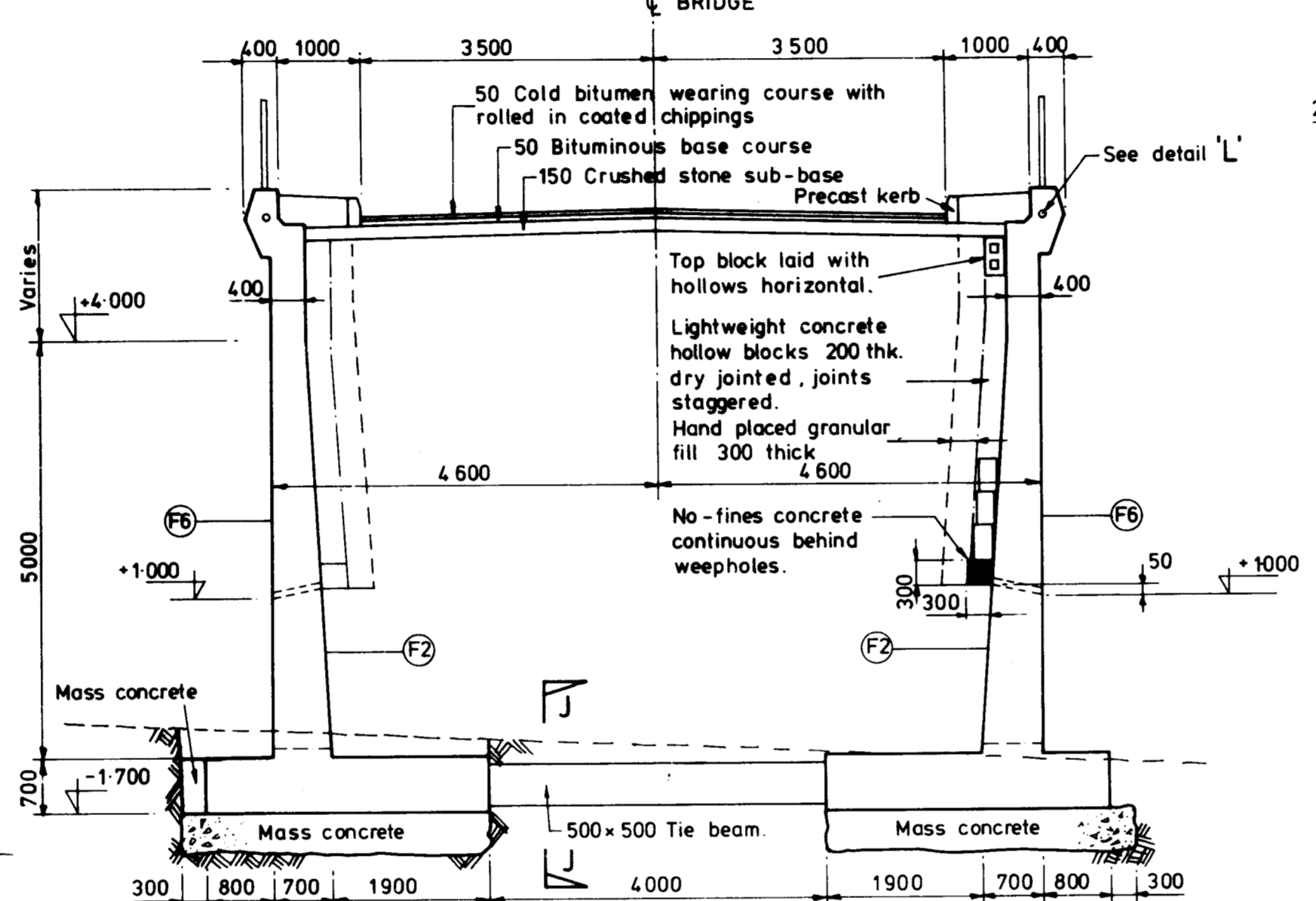

SECTION D-D

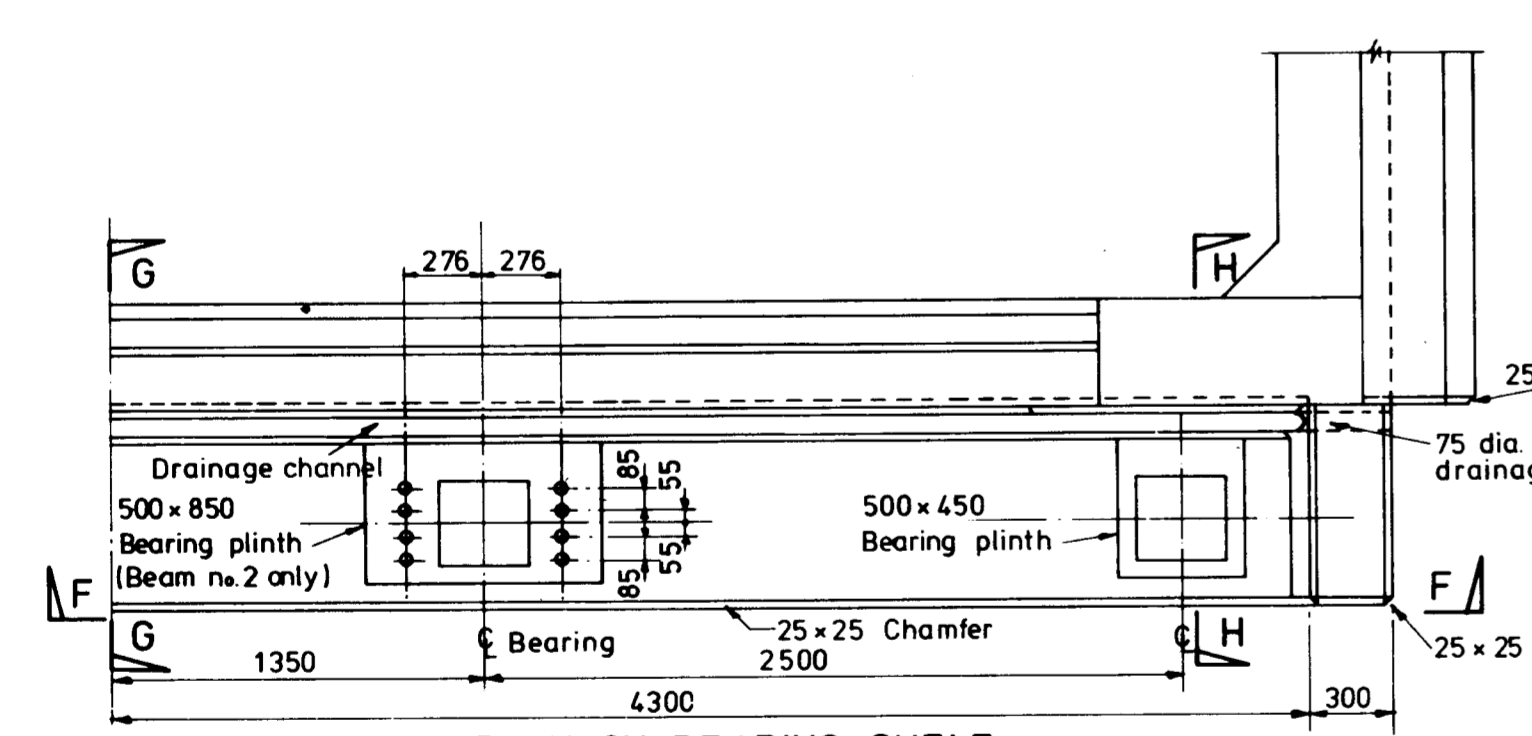

HALF PLAN ON BEARING SHELF

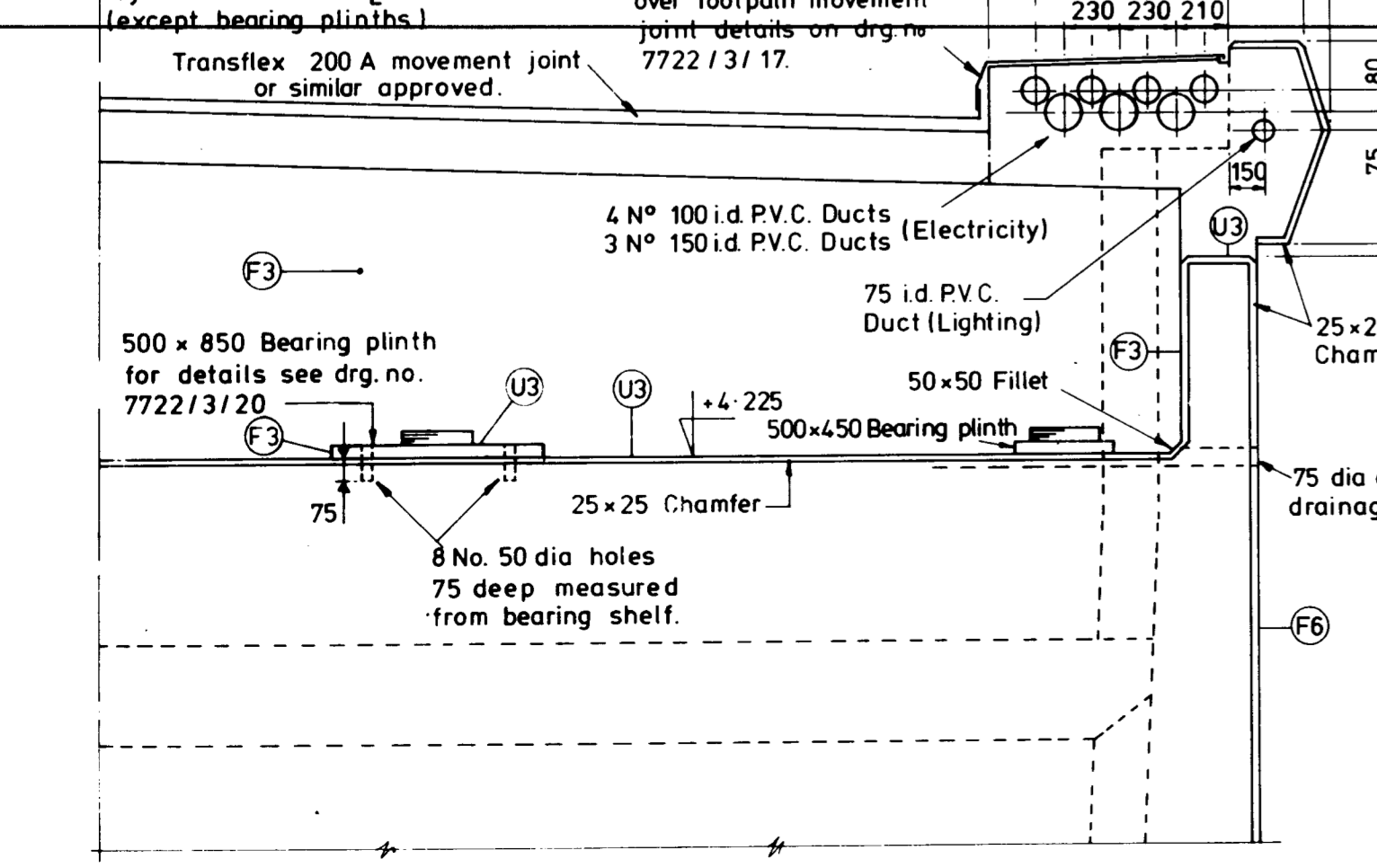

ELEVATION F-F

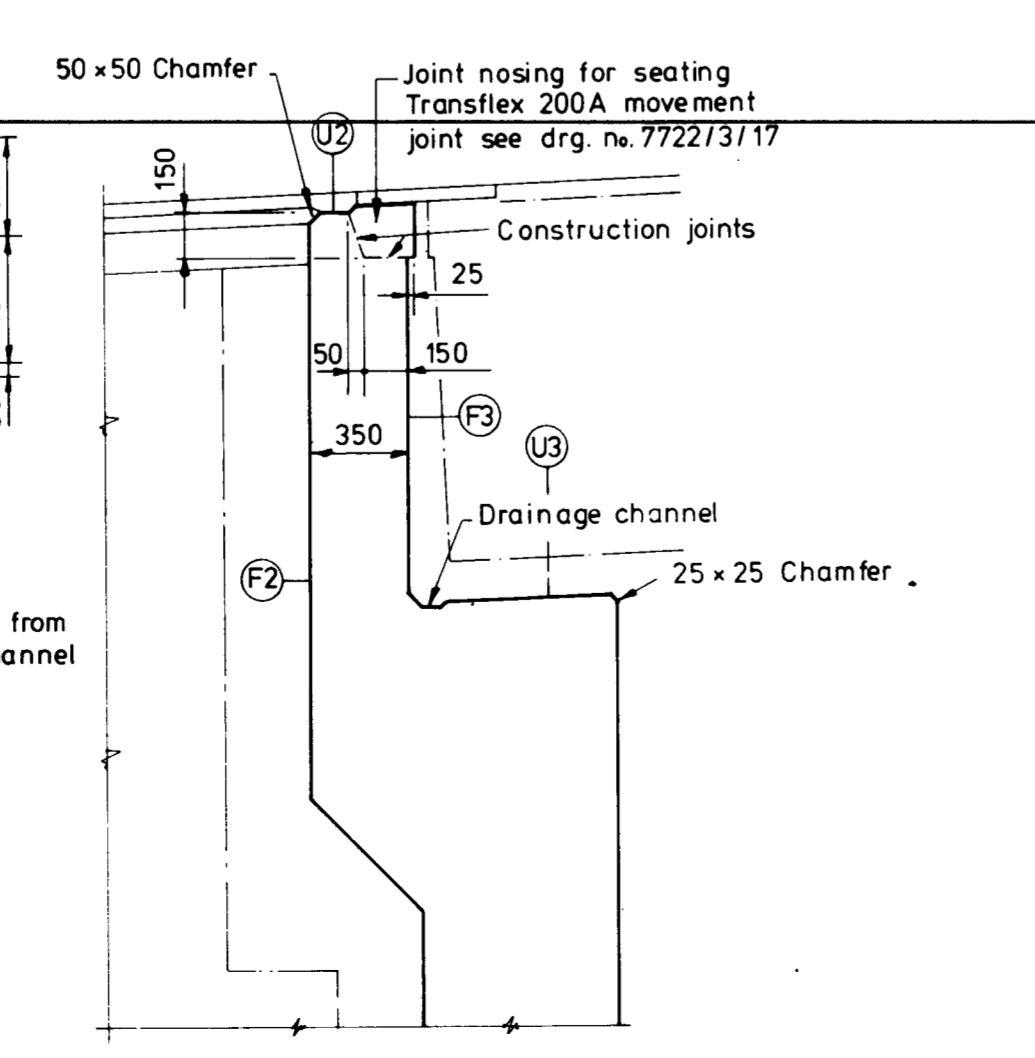

SECTION G-G

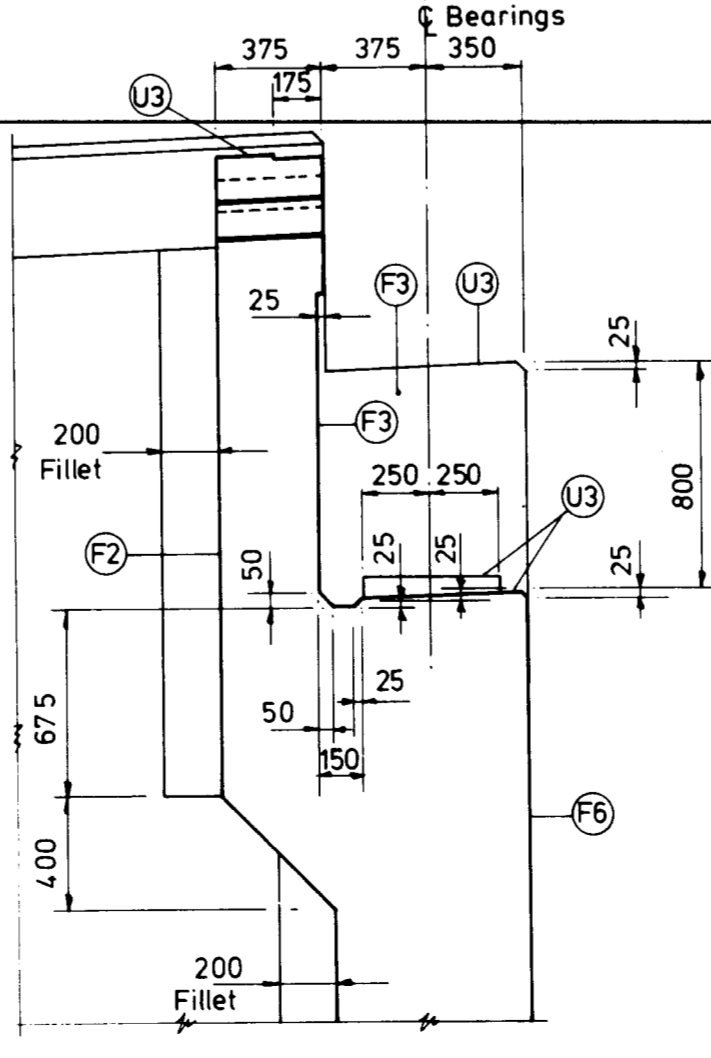

SECTION H-H

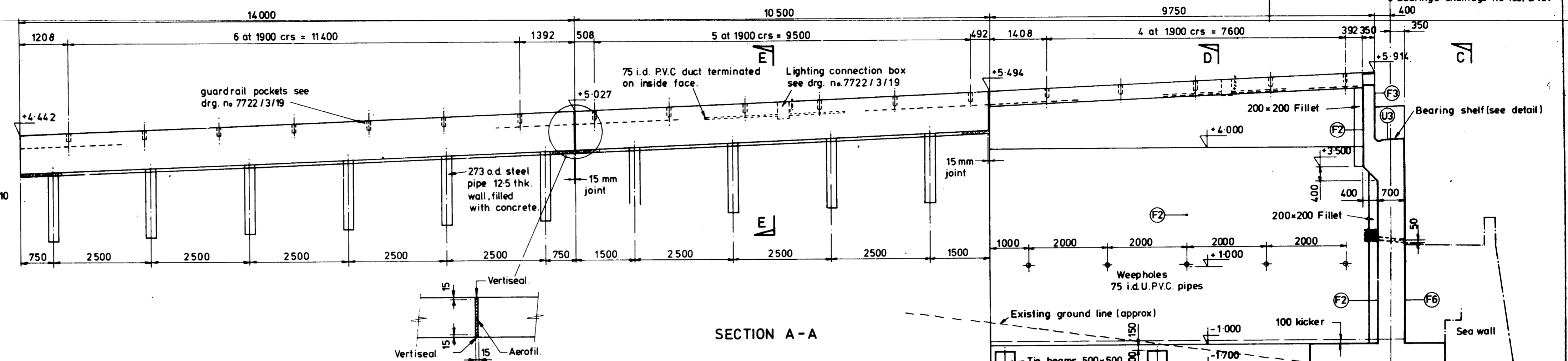

SECTION A-A

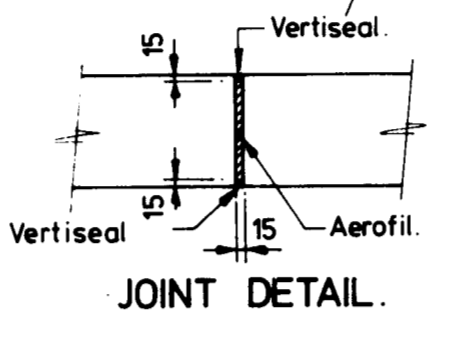

JOINT DETAIL

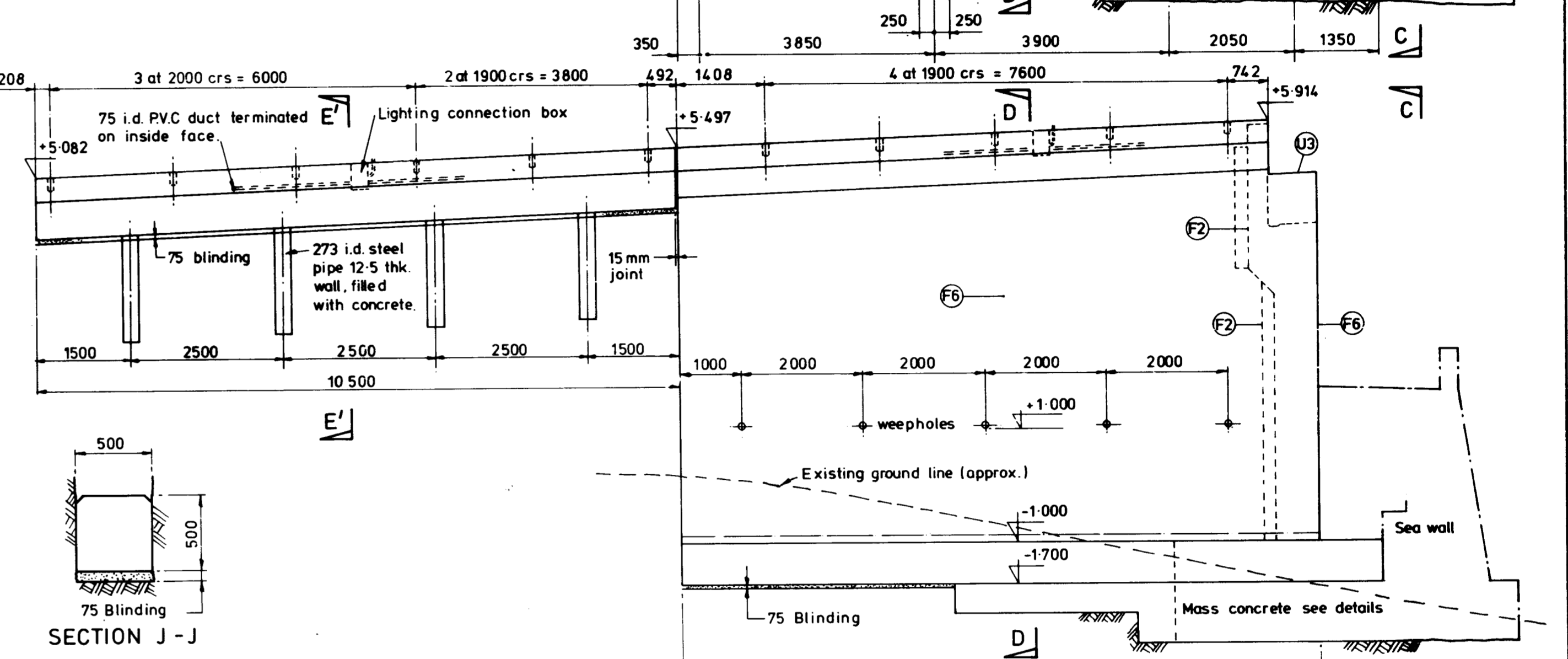

SECTION J-J

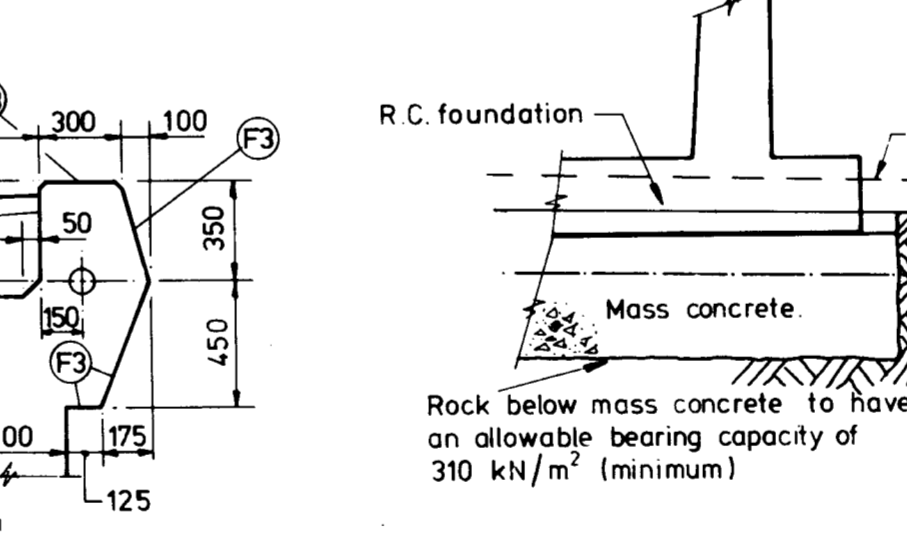

DETAIL 'L'

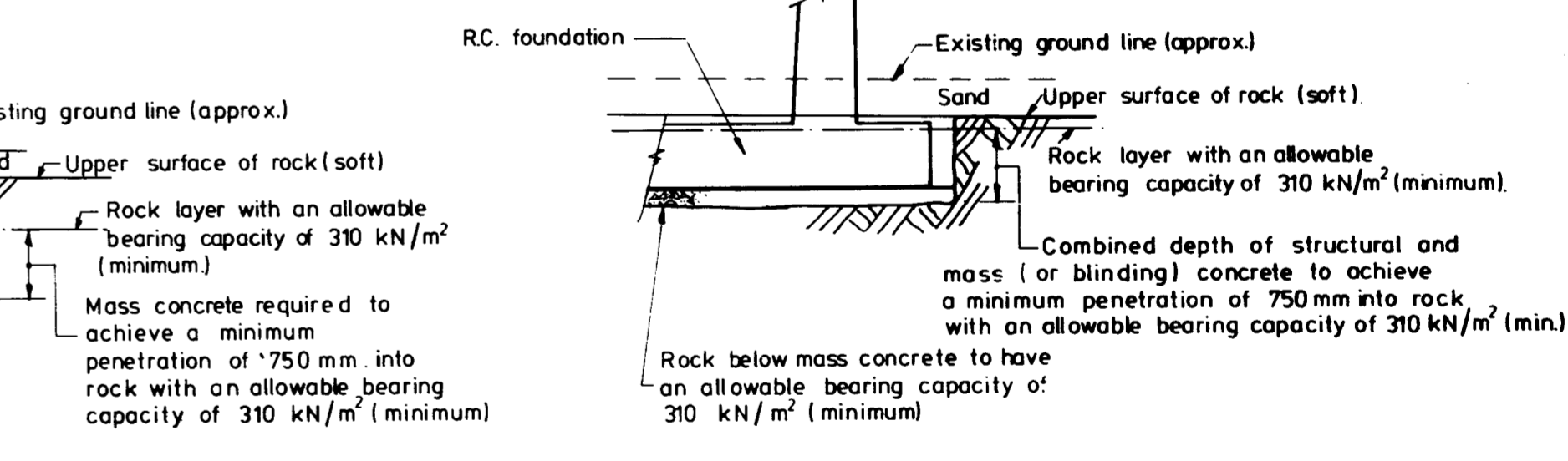

DETAIL 'K'

TO ESTABLISH FOUNDING LEVEL FOR MASS CONCRETE UNDER BASE OF WALL

- Notes :-
- All dimensions are in millimetres.
 - Levels are given to Datum 0.000 at Mean Sea level.
 - Surface finishes - denoted on drawing thus F3 formed surfaces to be F1 unless otherwise noted. Unformed surfaces to be U1 unless otherwise noted.
 - All sealant and joint fillers as Servisiced (W.R. Grace Ltd.) or similar approved and installed in accordance with manufacturers specification. Sealant colour to be "Standard Grey".
 - This drawing to be read in conjunction with the following drawings :-
7722 / 3 / 2 - Vertical and Horizontal Alignment (and the Setting Out Book)
7722 / 3 / 6 - Somerset Island Approach, Scheme 1.
7722 / 3 / 8 - Somerset Abutment R.C. Details, Scheme 1.
7722 / 3 / 19 - Guardrail & Lighting Details.
7722 / 3 / 20 - Bearing Schedule & Details.

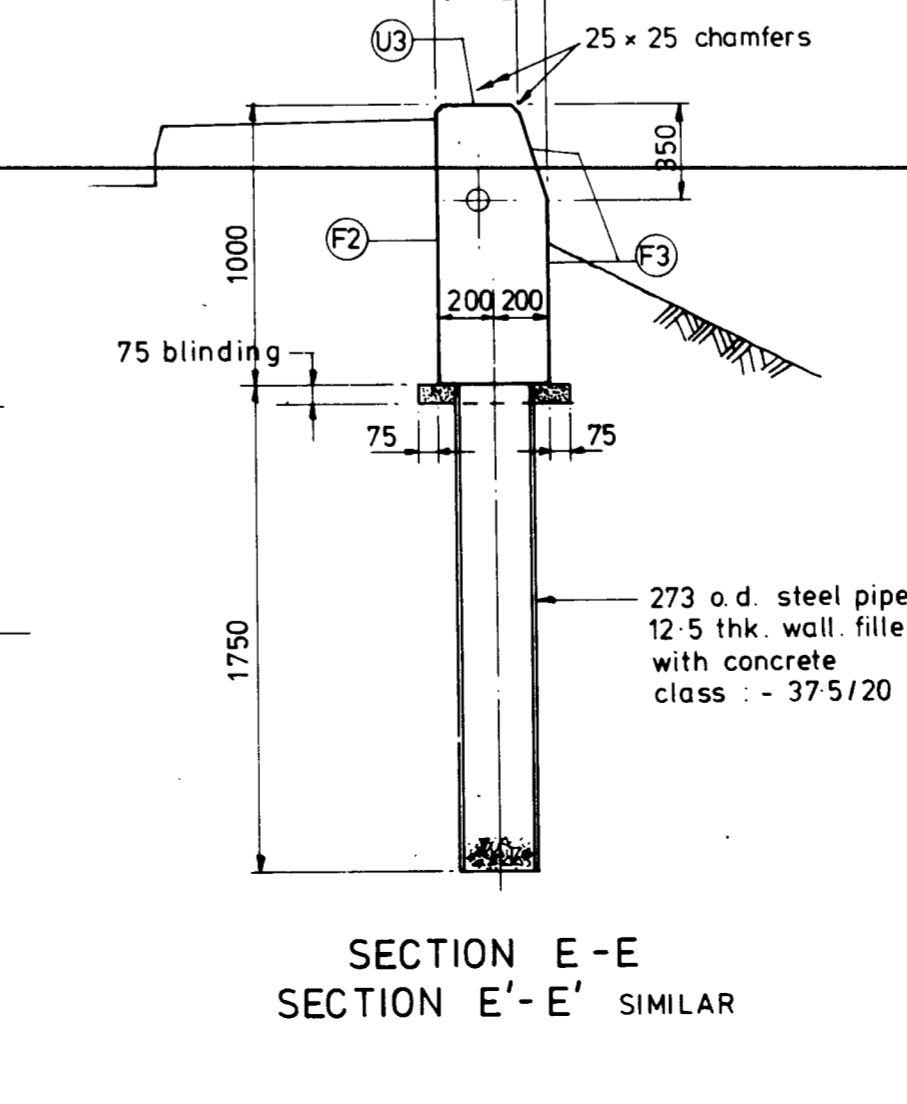

**SECTION E-E
SECTION E'-E' SIMILAR**

REV.	DESCRIPTION	DATE	CHECKED
GOVERNMENT OF BERMUDA			
NEW WATFORD BRIDGE			
SOMERSET ABUTMENT GENERAL ARRANGEMENT SCHEME 1			
PUBLIC WORKS DEPT. HAMILTON 5 BERMUDA		G. MAUNSELL & PARTNERS CONSULTING ENGINEERS LONDON S.E. 20	
SCALE: 1:200, 1:50, 1:20	DRG. NO. 7722/3/7		
DATE: MAY 1979	DRAWN BY: ME		

BAR LOCATING TABLE

Bending Schedule No. 2381

Bar Mark	Grouping	Shape	Crs	Total No.
FRONT WALL (1 NO)				
25 01 Y	1 x	23	38	175
16 02 T	1 x	23	38	175
25 03 Y	2 x	19	38	175
16 04 Y	2 x	19	20	175
16 05 Y	1 x	23	38	175
16 06 Y	2 x	19	37	175
15 07 Y	2 x	19	38	175
16 08 T	2 x	19	20	175
16 08 Y	2 x	19	20	175
16 09 Y	2 x	19	37	175
16 10 Y	2 x	2	37	175
14 11 Y	1 x	52	37	175
16 12 Y	1 x	52	38	175
20 13 Y	1 x	24	37	350
25 18 Y	2 x	20	37	350
16 15 Y	1 x	49	37	175
16 16 Y	1 x	40	37	175
16 17 Y	1 x	40	62	150
12 18 Y	1 x	24	62	350
12 19 Y	1 x	40	62	350
16 20 Y	2 x	21	20	175
16 21 Y	2 x	21	37	175
16 22 Y	2 x	21	37	175
16 23 Y	2 x	3	37	150
16 24 Y	2 x	3	37	150
16 25 Y	2 x	3	20	150
16 26 Y	2 x	8	37	125
25 27 Y	2 x	9	37	150
25 28 Y	1 x	9	20	125
16 29 Y	1 x	20	20	150
16 30 Y	1 x	4	20	200
12 31 Y	2 x	8	20	195
12 32 Y	1 x	8	38	175
12 33 Y	2 x	8	48	175
12 34 Y	2 x	24	62	175
10 35 Y	2 x	2	37	175
10 36 Y	2 x	2	37	200
NORTH/SOUTH SIDE WALLS (2 NO)				
16 34 Y	1 x	2	20	2
16 40 Y	1 x	47	95	175
25 41 Y	1 x	47	38	175
15 42 Y	2 x	19	20	175
16 42 Y	1 x	2	20	2
16 43 Y	2 x	19	20	175
16 44 Y	1 x	19	38	175
16 45 Y	1 x	2	38	2
25 47 Y	1 x	48	37	200
25 48 Y	1 x	48	37	200
16 40 Y	1 x	48	37	200
16 50 Y	1 x	48	37	200
16 51 Y	1 x	48	37	200
16 52 Y	1 x	4	37	200
16 53 Y	1 x	4	37	200
16 44 Y	1 x	19	38	175
10 55 Y	1 x	4	38	200
16 56 Y	1 x	18	20	200
16 57 Y	2 x	5	20	200
15 58 Y	1 x	8	20	200
12 59 Y	1 x	65	33	150
12 60 Y	1 x	65	33	150
16 61 Y	1 x	21	37	175
20 62 Y	1 x	10	37	150
16 63 Y	2 x	8	20	200
16 64 Y	1 x	18	20	200
16 65 Y	1 x	5	37	250
16 140 T	6 x	2	20	12
TIE BEAMS (2 NO)				
10 130 T	2 x	2	40	4
25 131 Y	1 x	12	50	300
25 132 T	2 x	12	20	12
BEARING PLINTHS 500x450 (3 NO)				
10 130 T	1 x	4	38	4
10 131 T	1 x	4	38	4
10 137 Y	1 x	2	60	2
BEARING PLINTHS 500x850 (1 NO)				
12 155 Y	1 x	4	38	4
12 146 Y	1 x	7	38	7
10 147 Y	1 x	2	60	2
GROUND BEAM TYPE 1 (2 NO)				
16 150 Y	2 x	8	20	8
16 151 Y	7 x	2	20	14
12 152 Y	1 x	35	964	300
12 153 Y	1 x	2	964	2
14 153 Y	4 x	6	34	24
8 154 Y	4 x	4	85	16
GROUND BEAM TYPE 2 (1 NO)				
16 151 Y	7 x	2	20	14
12 152 Y	1 x	47	964	300
12 153 Y	1 x	2	964	2
14 153 Y	6 x	6	34	36
8 154 Y	6 x	4	85	24
16 155 Y	4 x	2	20	8
16 156 Y	4 x	2	20	8
STAIRCASE (1 NO)				
16 201 T	2 x	6	62	200
12 202 T	2 x	19	60	300
16 203 T	8 x	2	20	16
MESH REINFORCEMENT AS B283				

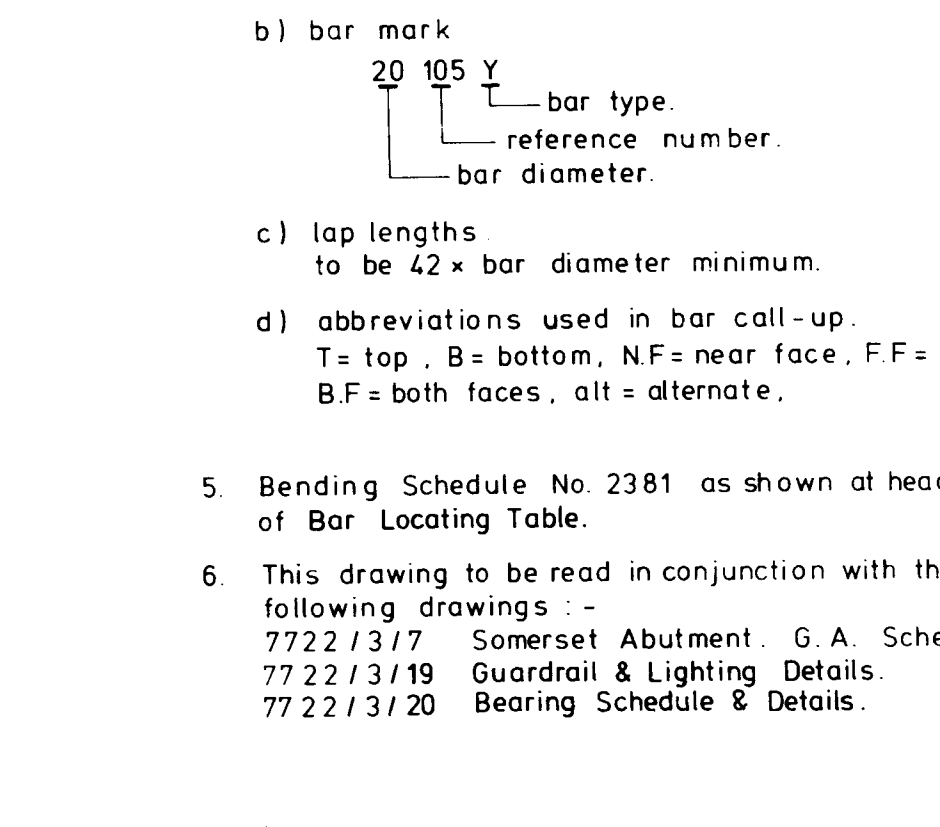
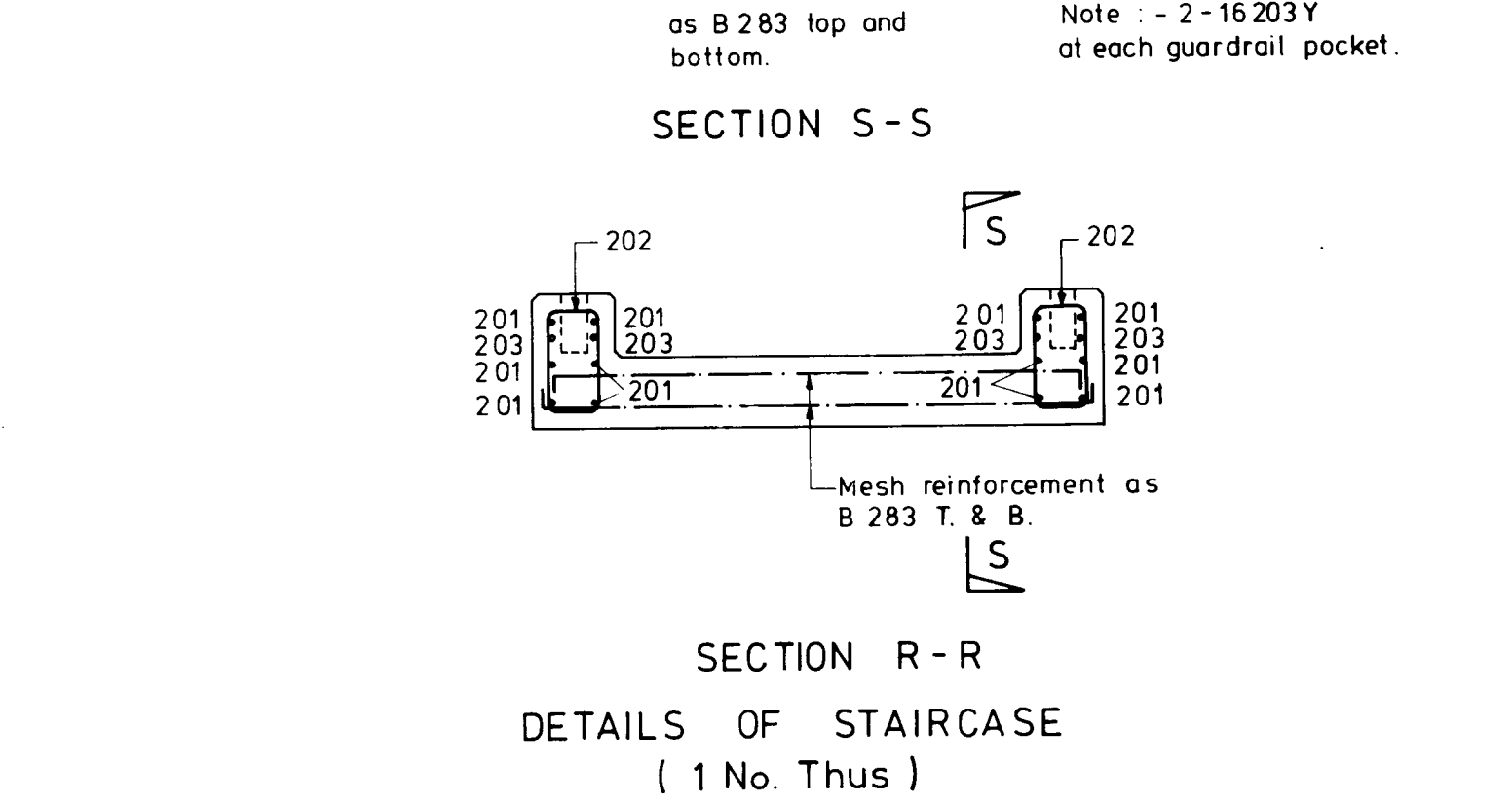
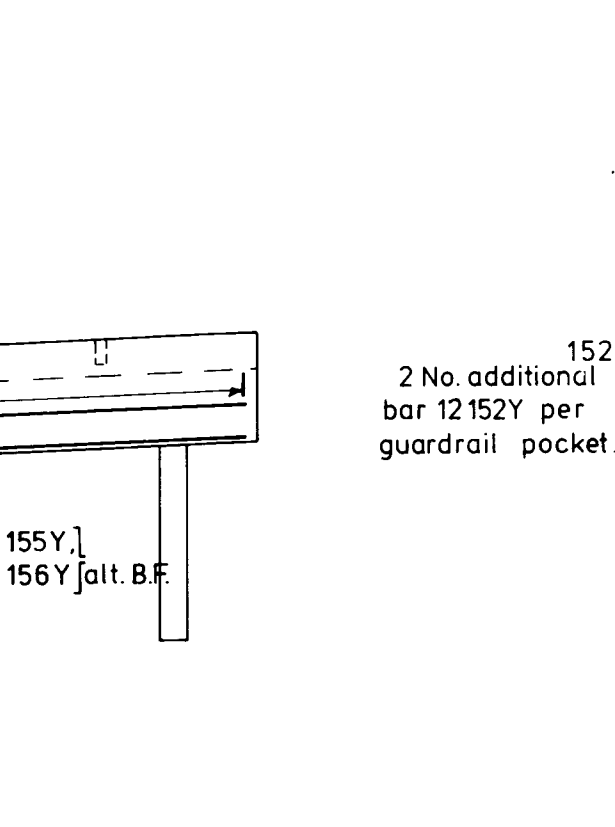
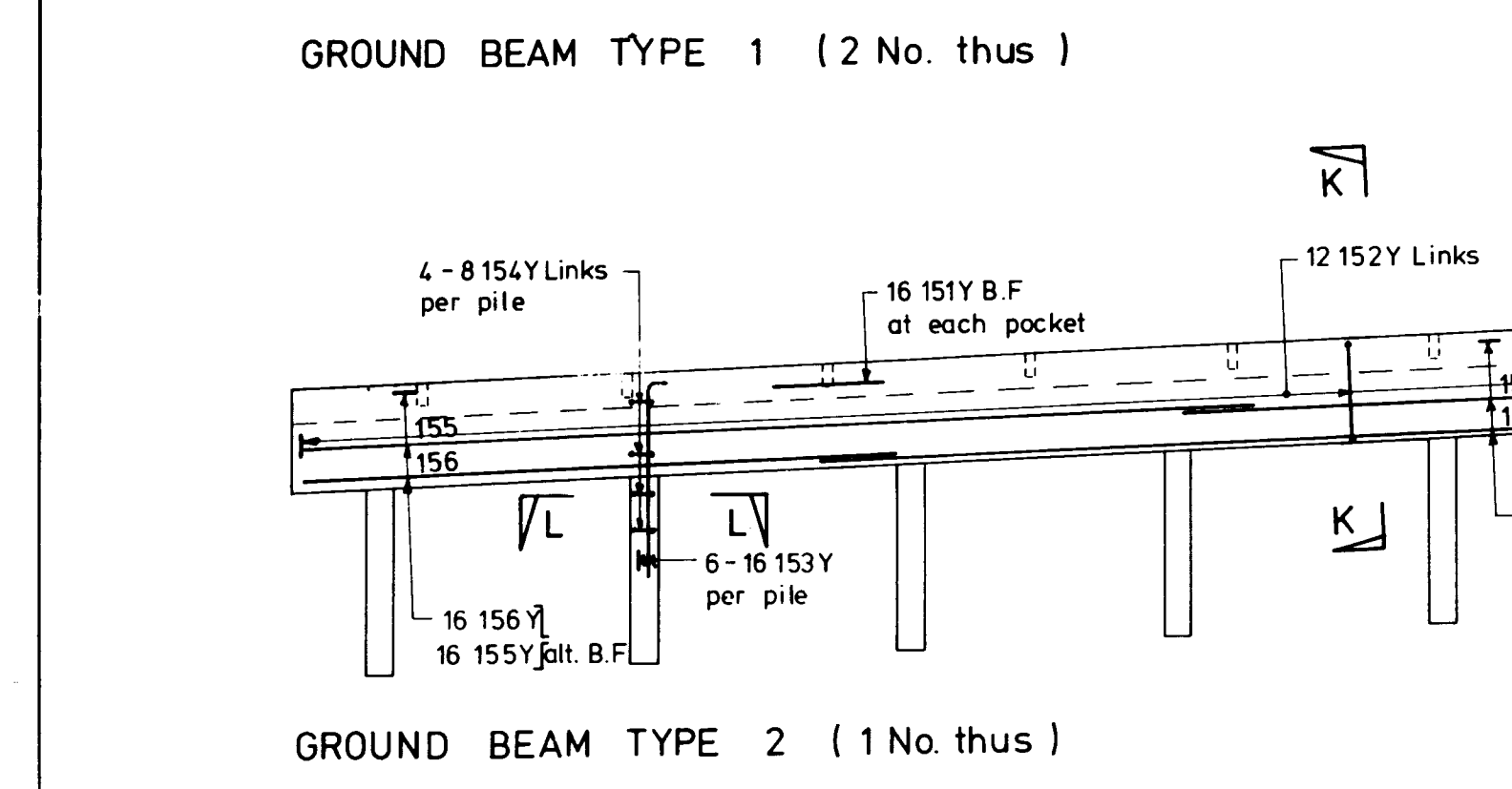
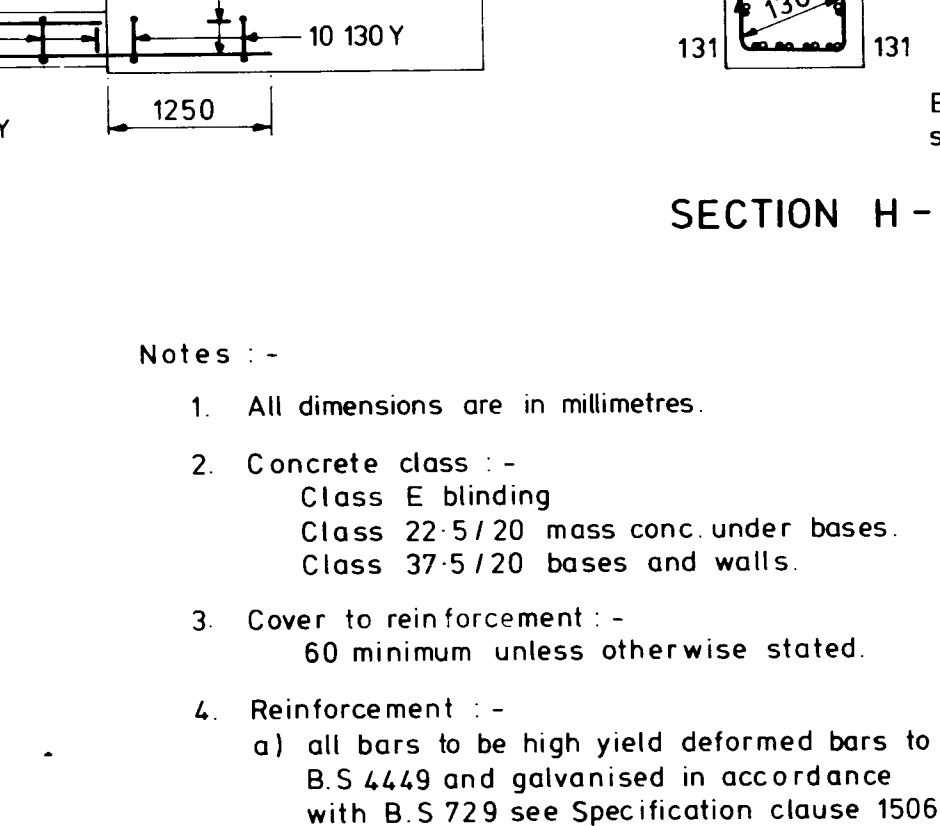
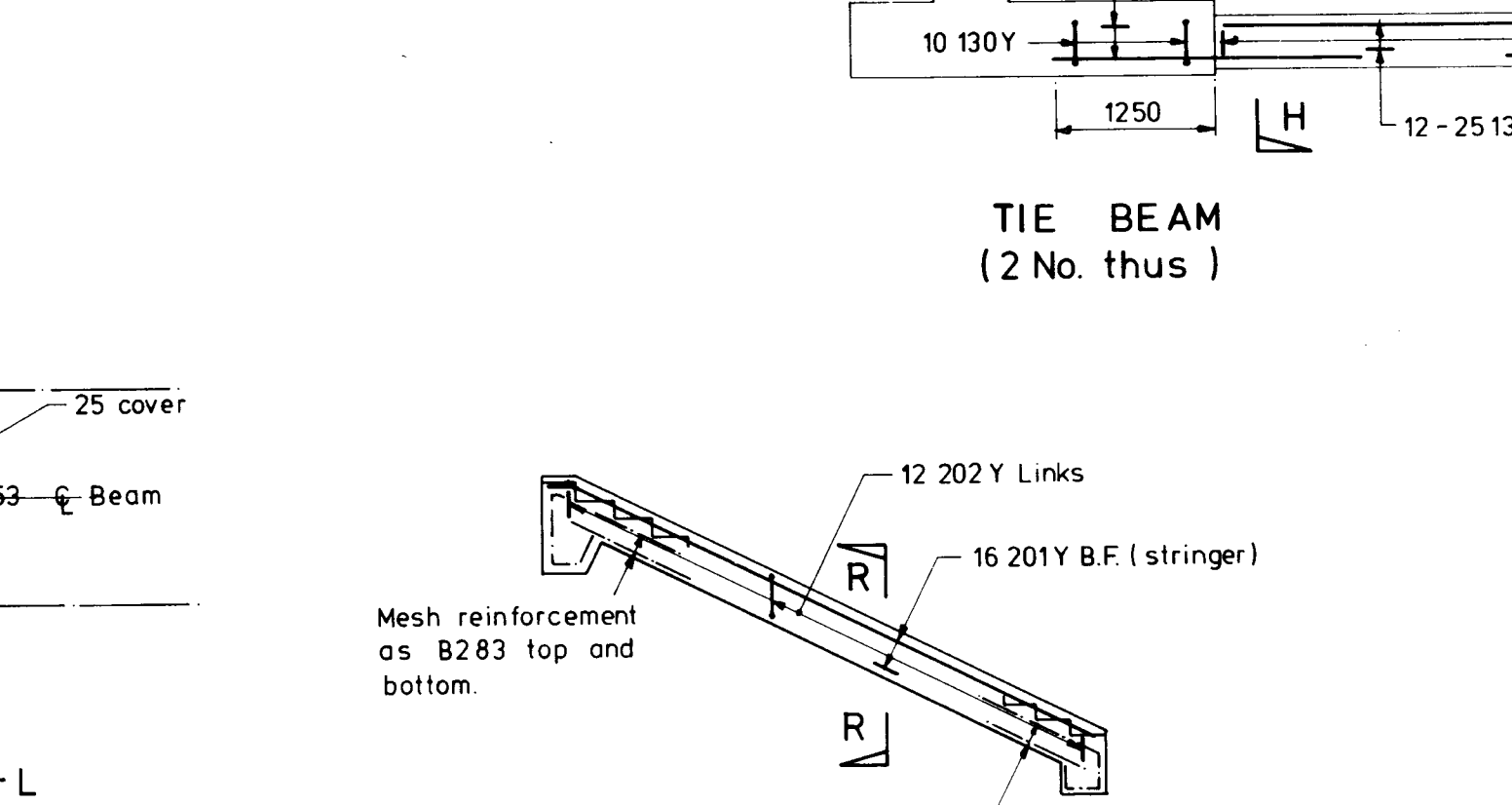
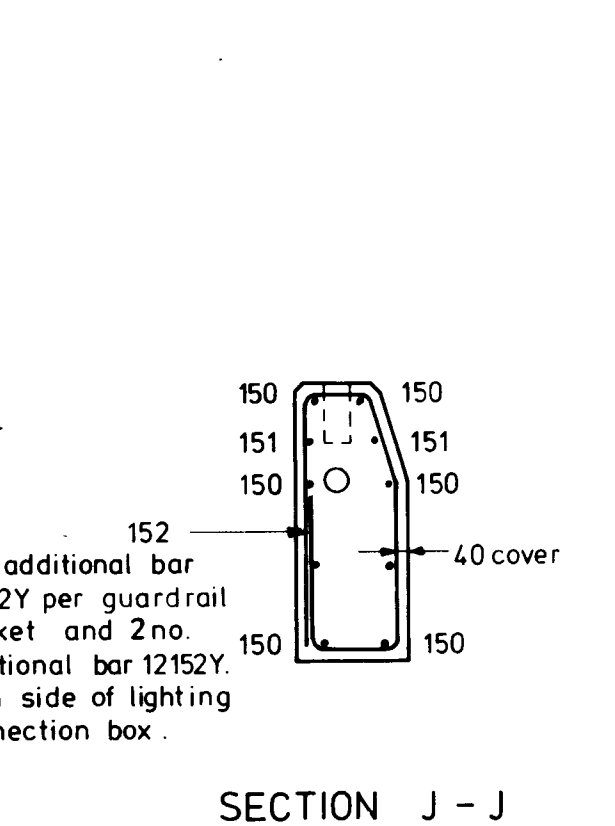
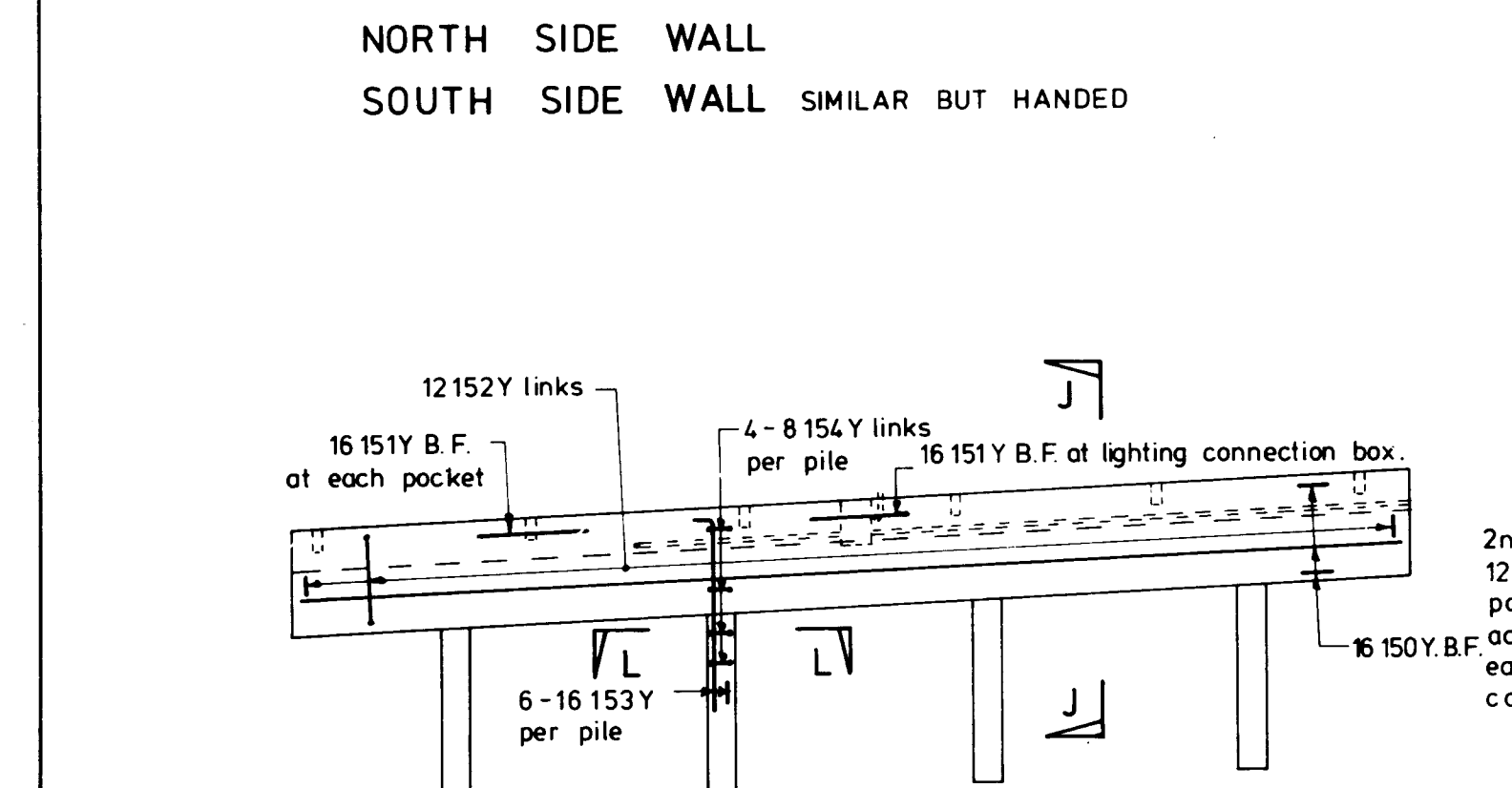
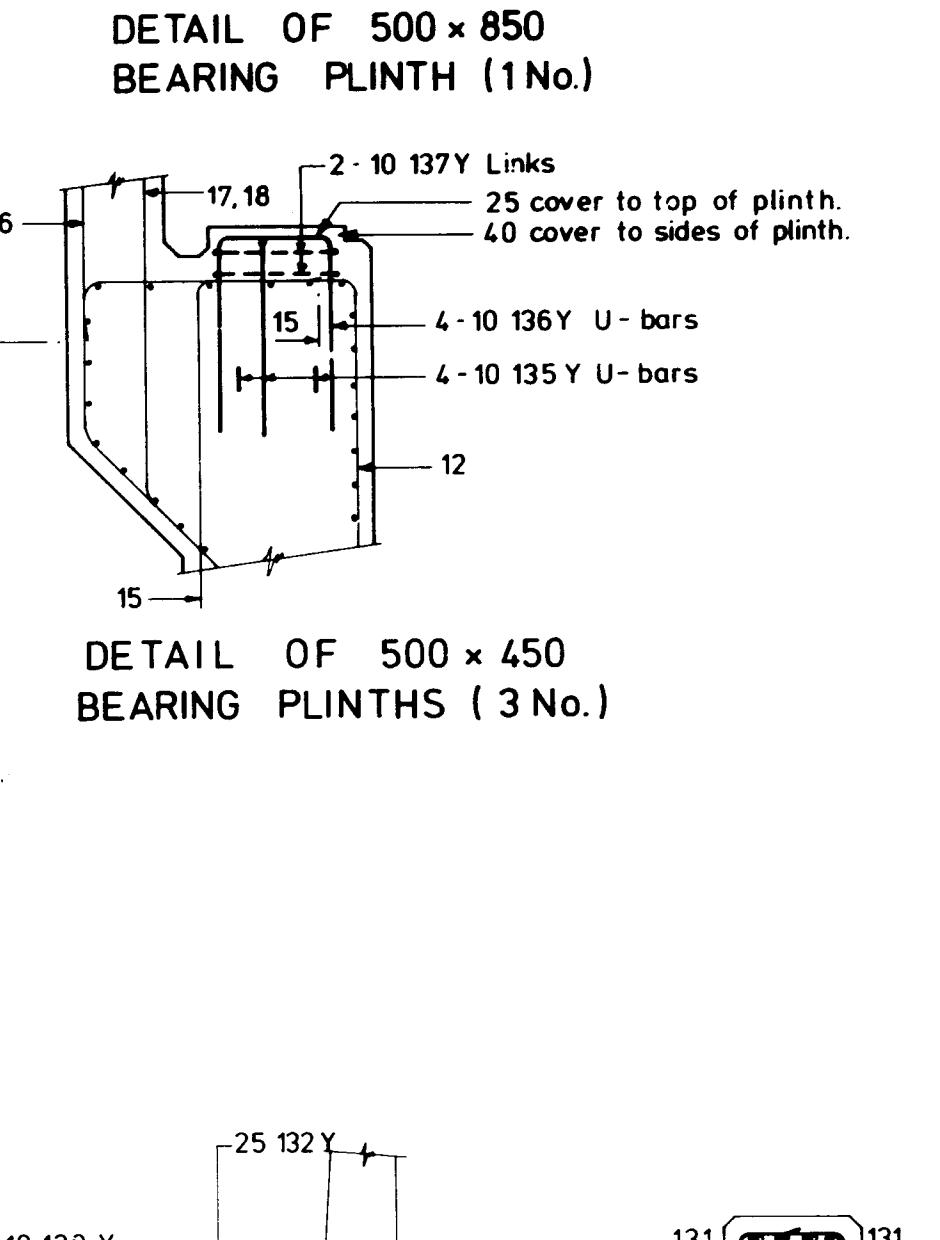
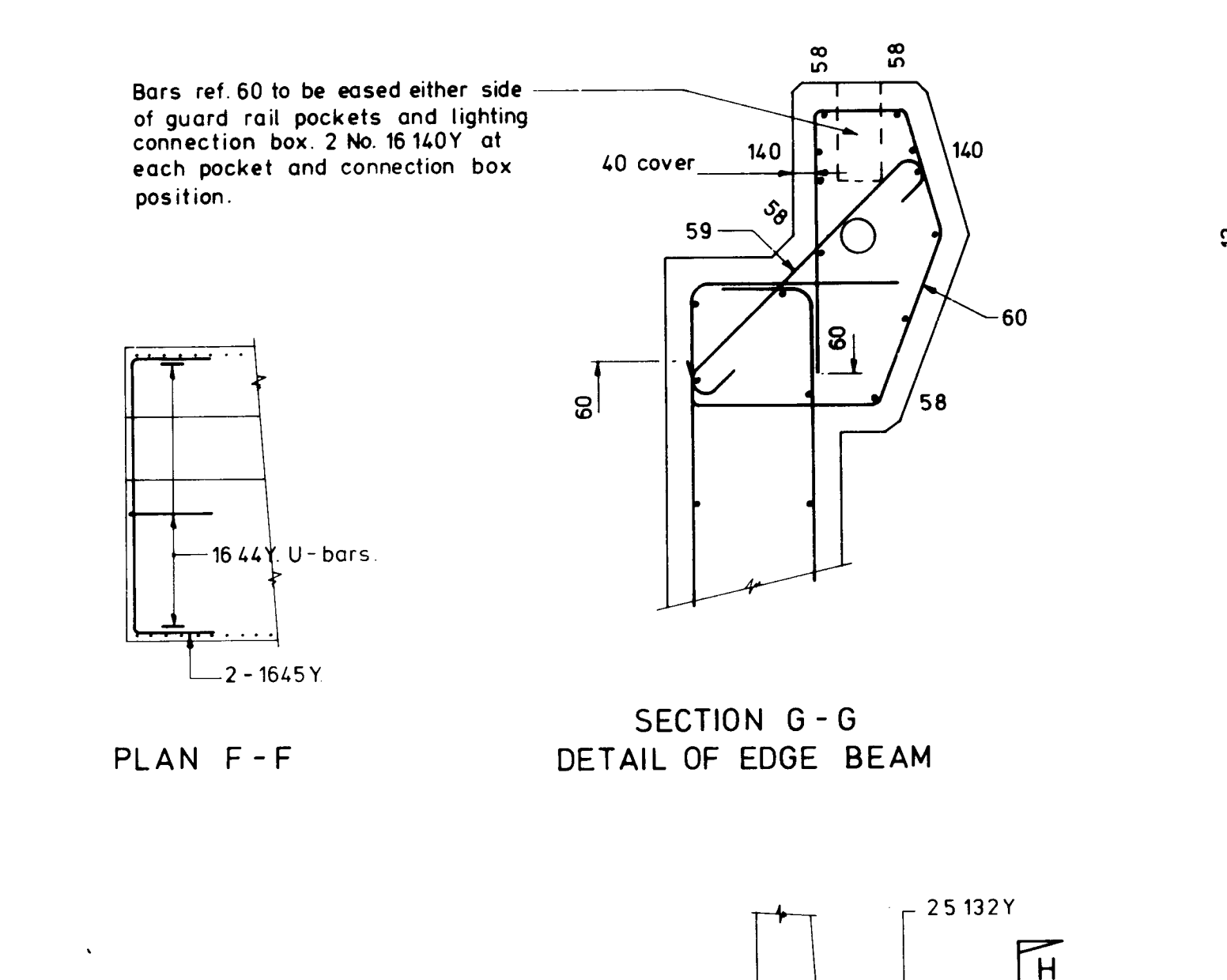
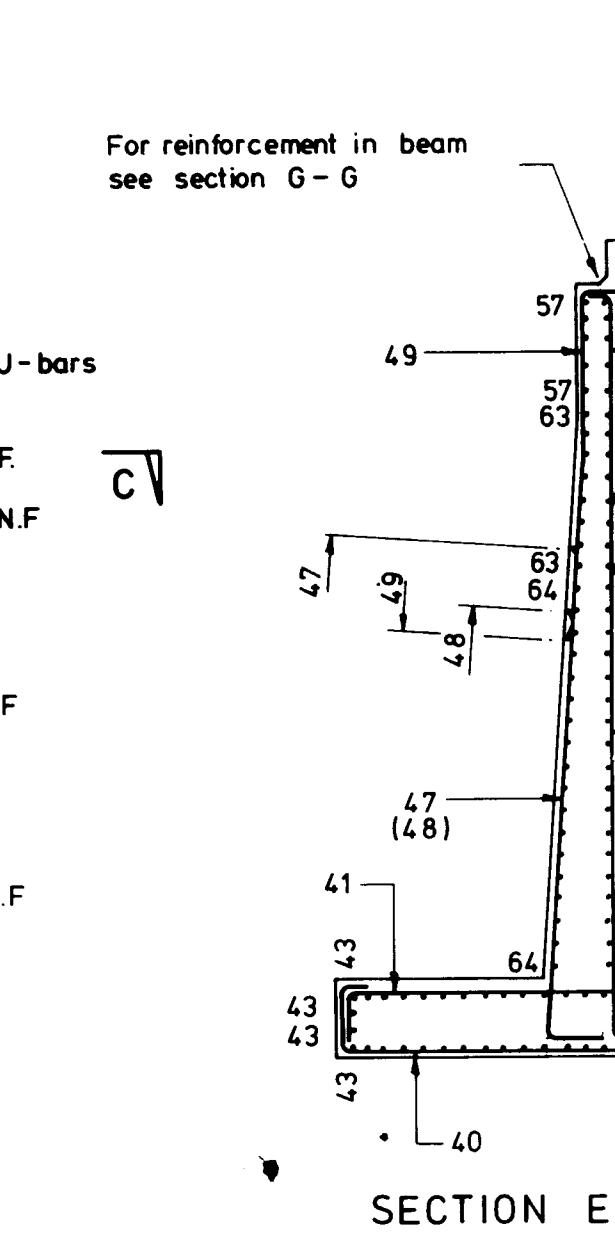
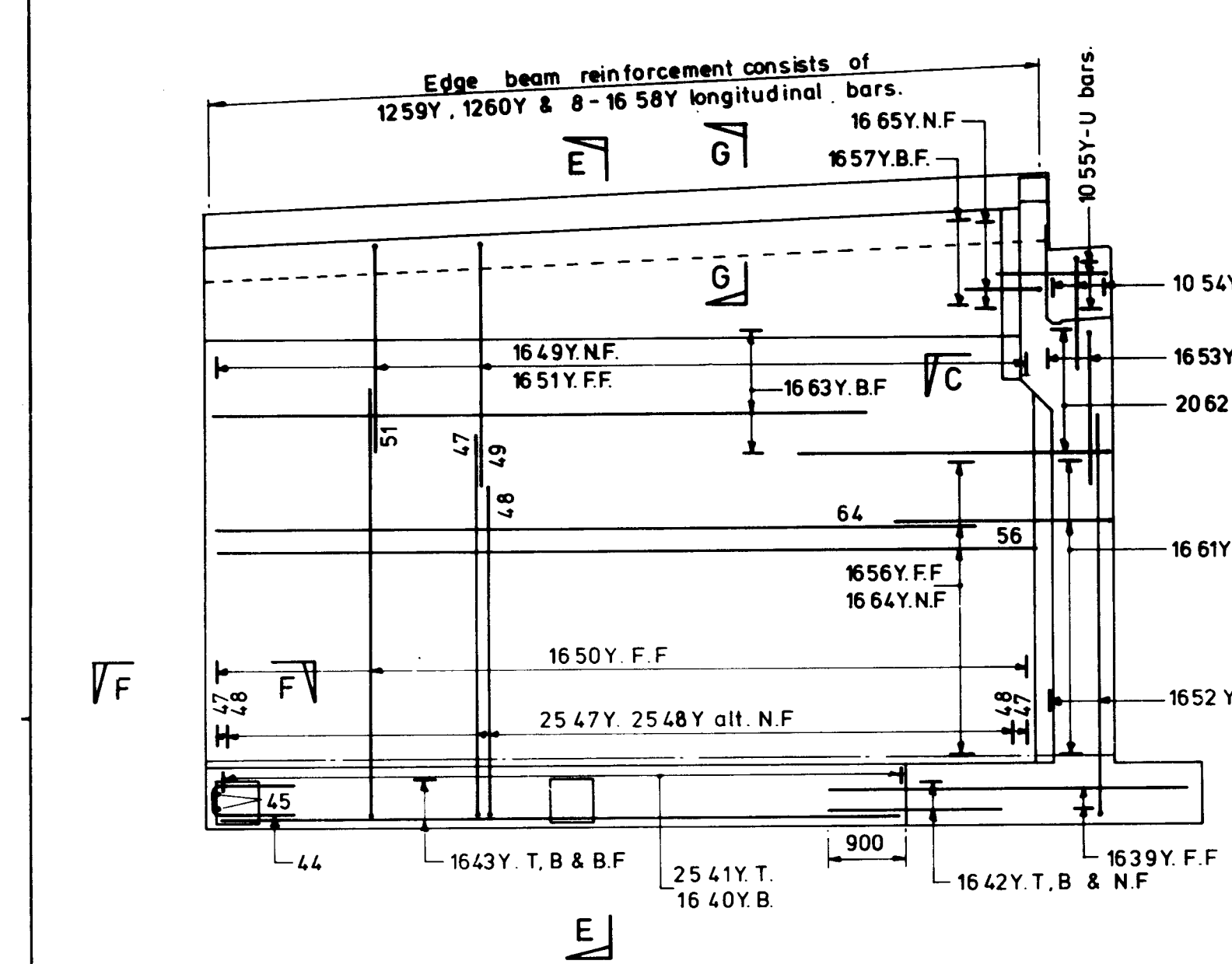
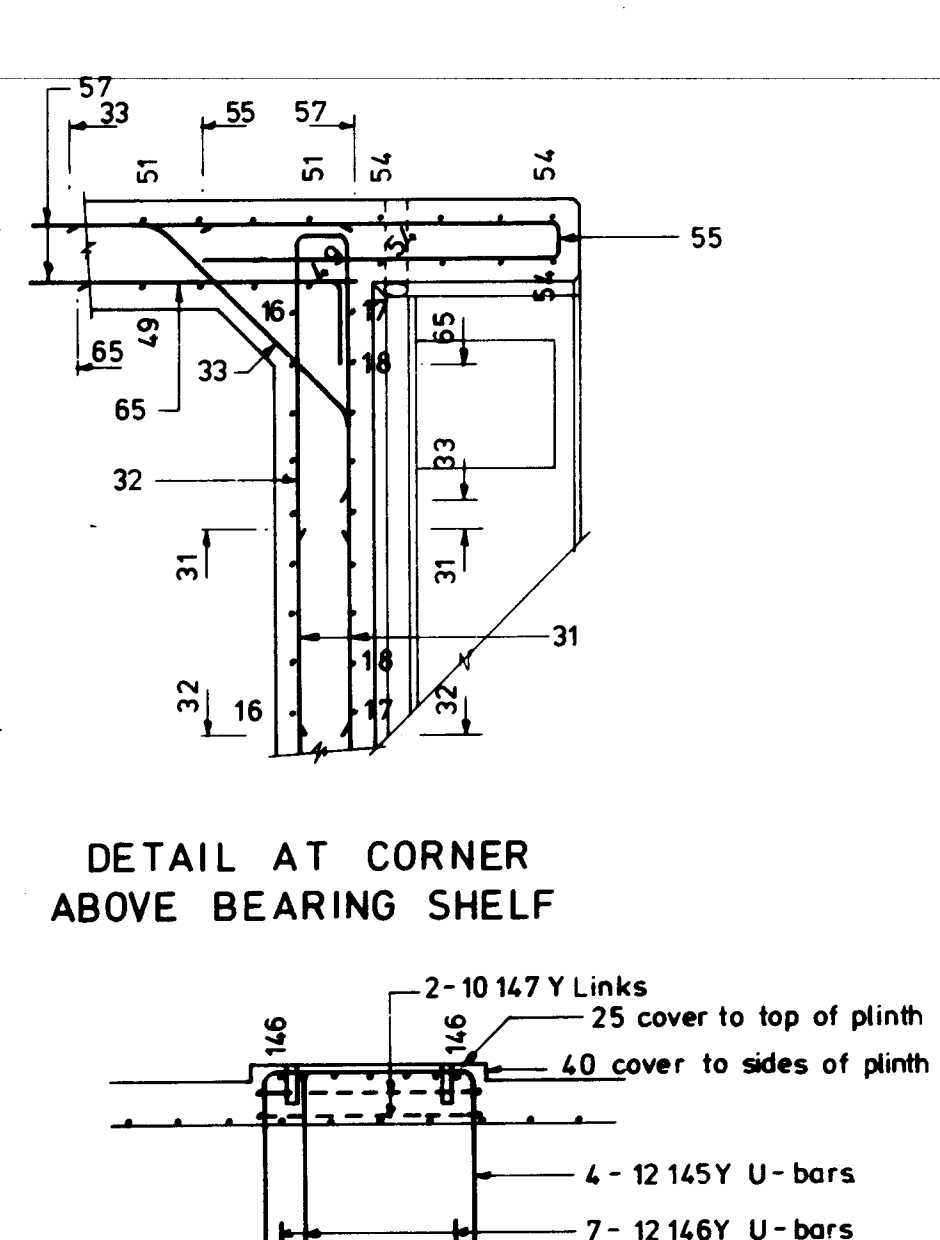
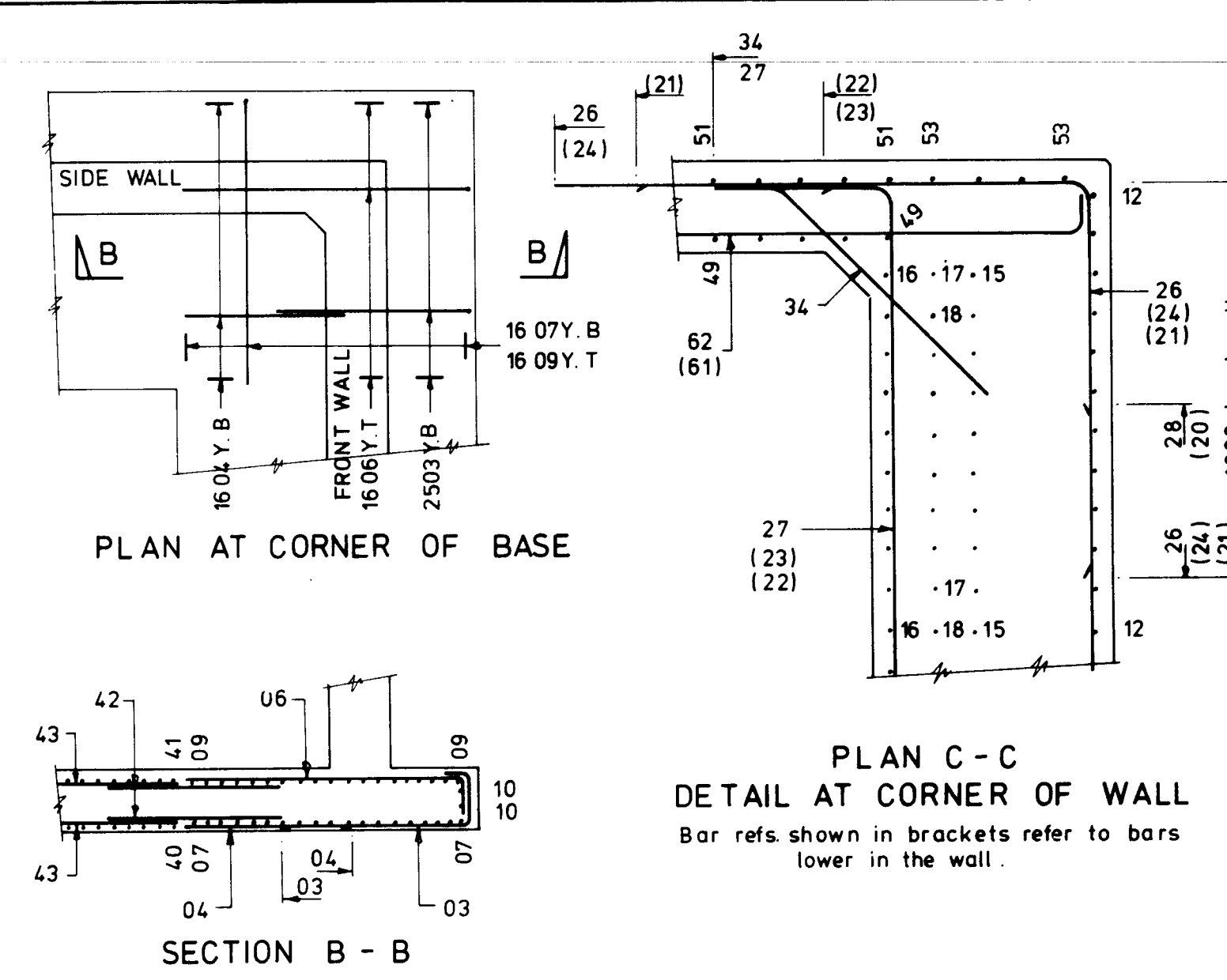
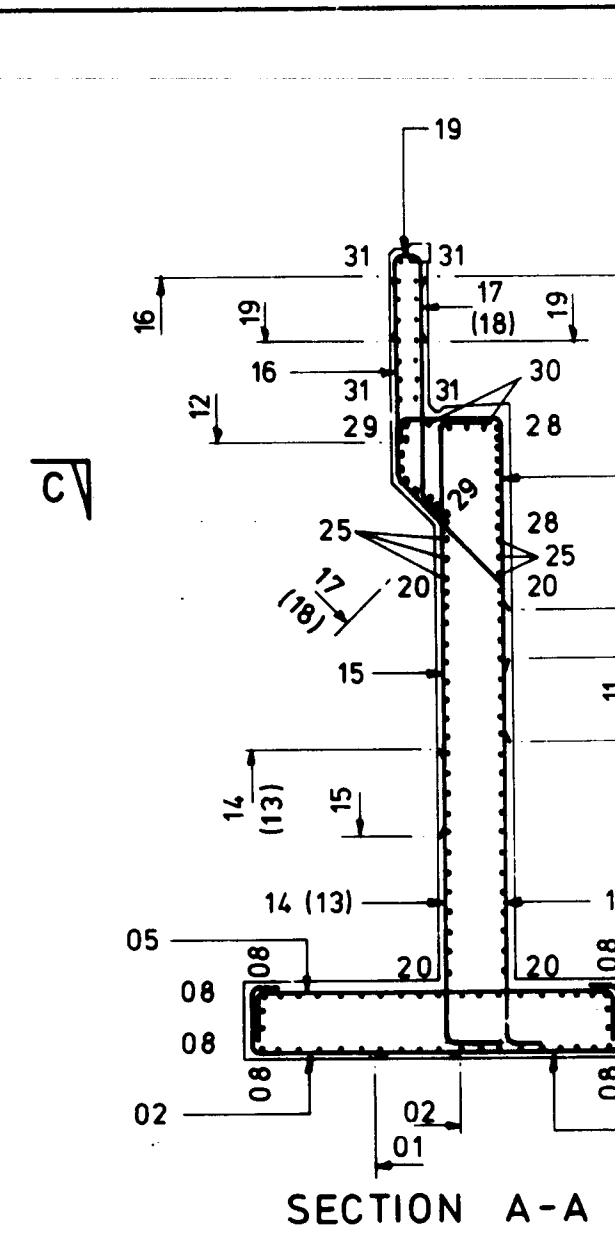
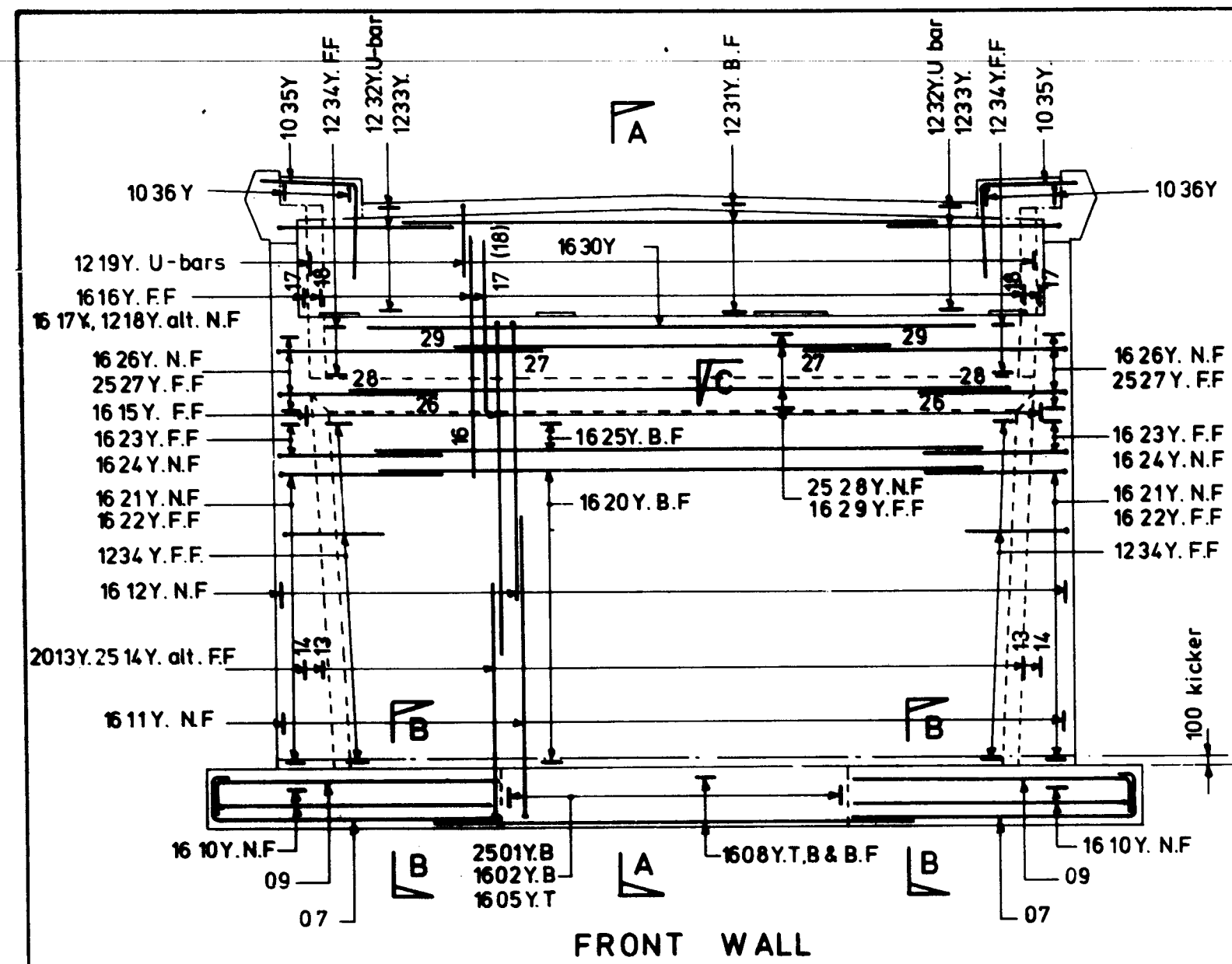

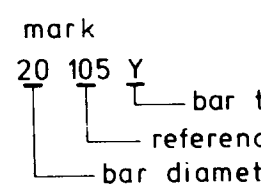
Notes :-
 1. All dimensions are in millimetres.
 2. Concrete class :-
 Class E binding
 Class 22.5/20 mass conc. under bases.
 Class 37.5/20 bases and walls.
 3. Cover to reinforcement :-
 60 minimum unless otherwise stated.
 4. Reinforcement :-
 a) all bars to be high yield deformed bars to B.S.4449 and galvanised in accordance with B.S.729 see Specification clause 1506. High yield bars are shown as bar type Y.
 b) bar mark

 — bar type.
 — reference number.
 — bar diameter.
 c) lap lengths
 to be 42 x bar diameter minimum.
 d) abbreviations used in bar call-up.
 T = top, B = bottom, N.F = near face, F.F = far face.
 B.F = both faces, alt = alternate.

REV. DESCRIPTION DATE CHECKED

GOVERNMENT OF BERMUDA
NEW WATFORD BRIDGE

SOMERSET ABUTMENT
 R.C. DETAILS
 SCHEME 1.

PUBLIC WORKS DEPT. HAMILTON 5 BERMUDA G. MAUNSELL & PARTNERS CONSULTING ENGINEERS LONDON S.E. 20.

SCALE: 1:50, 1:20, 1:10
 DATE: MAY 1979 DRAWN BY: ME DRG. NO: 7722/3/8

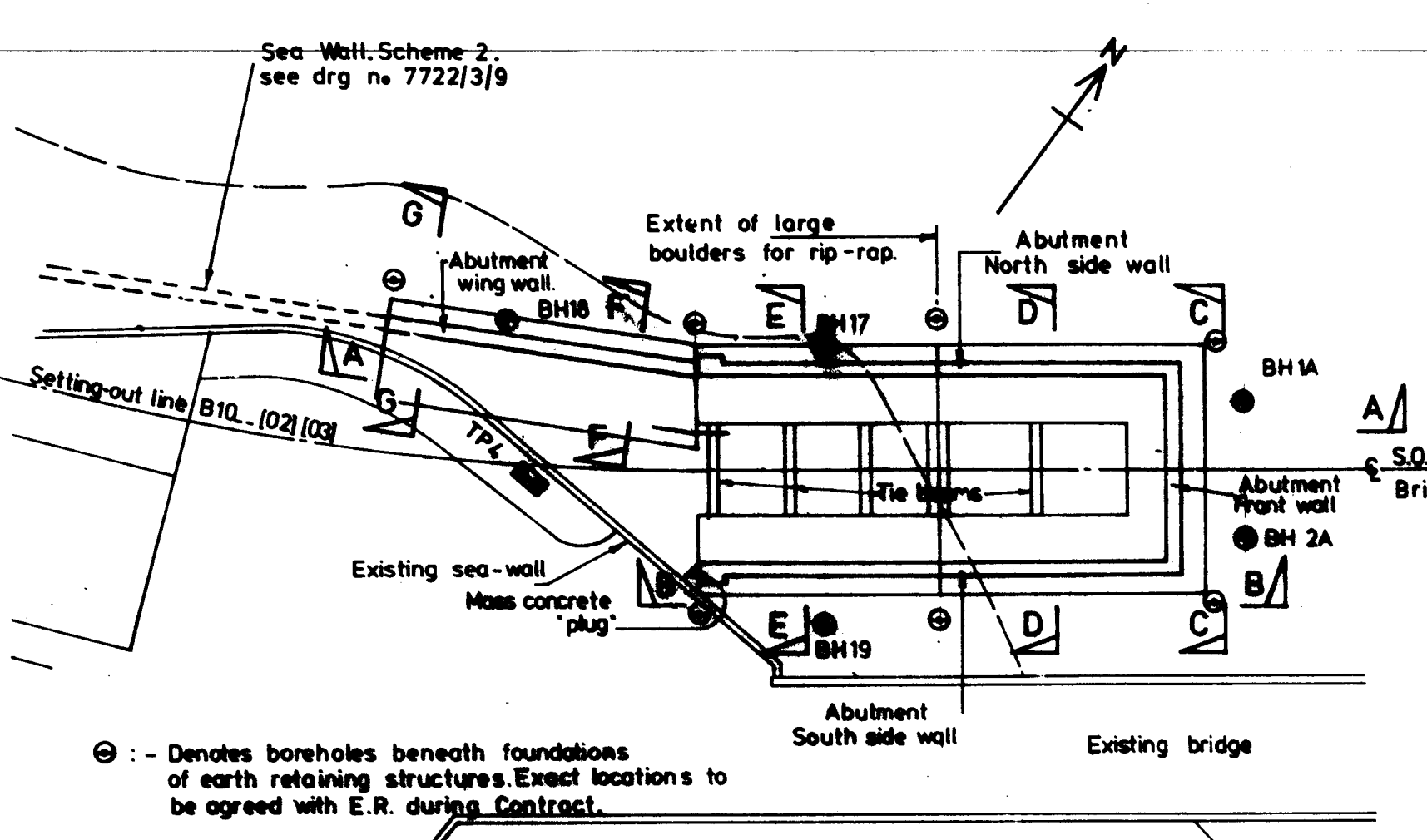

KEY PLAN

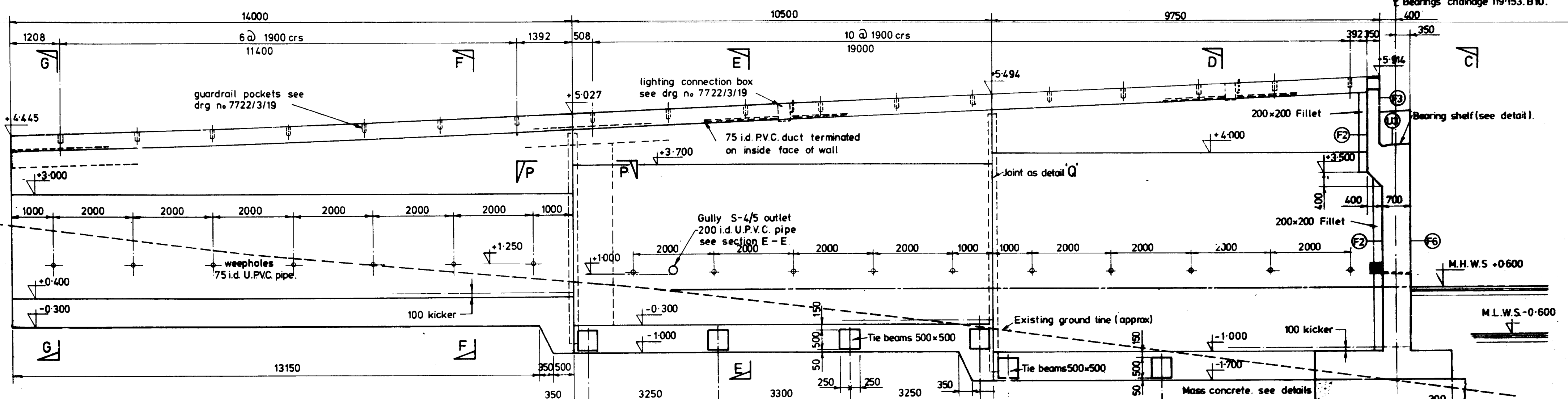

SECTION A-A

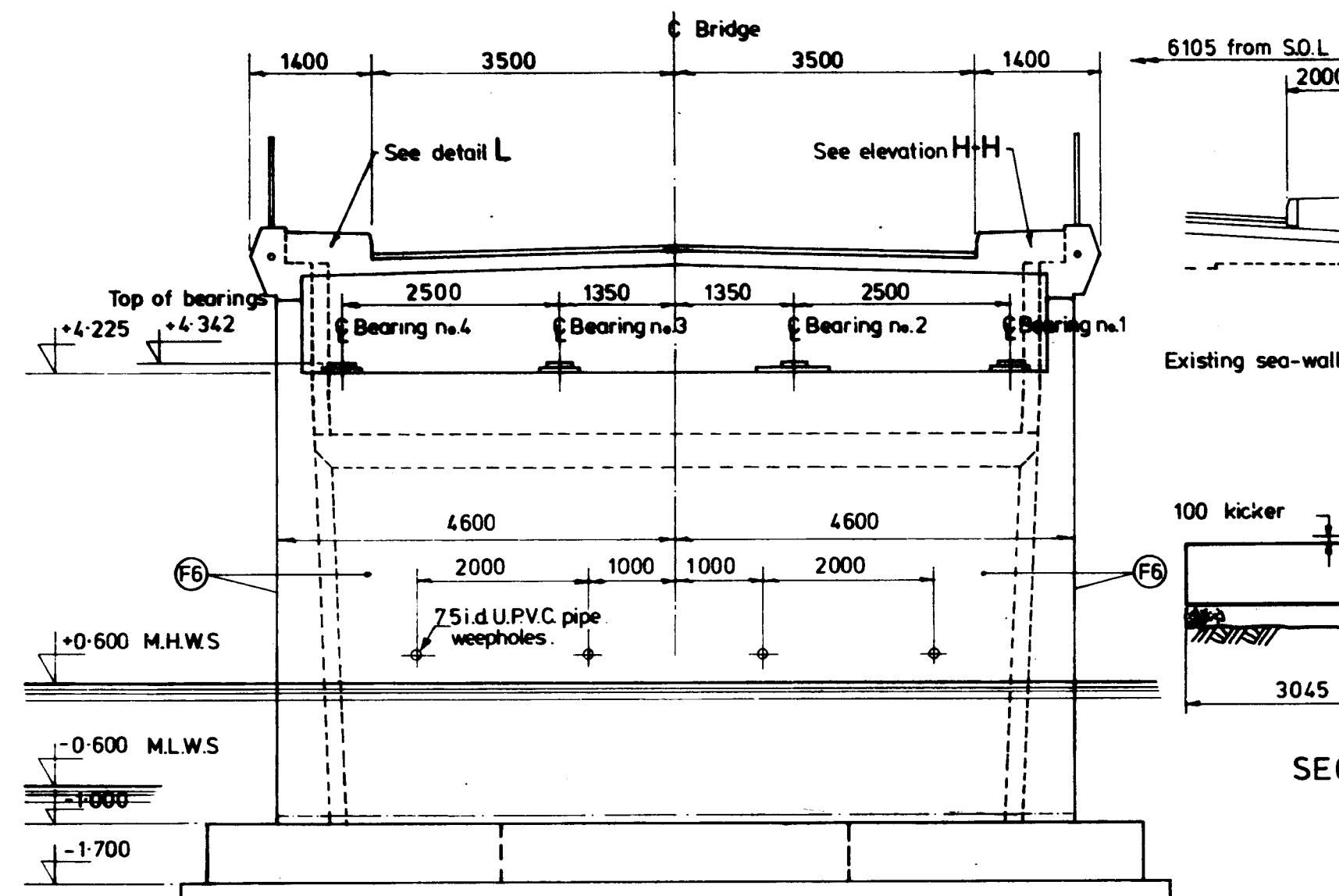

ELEVATION C-C

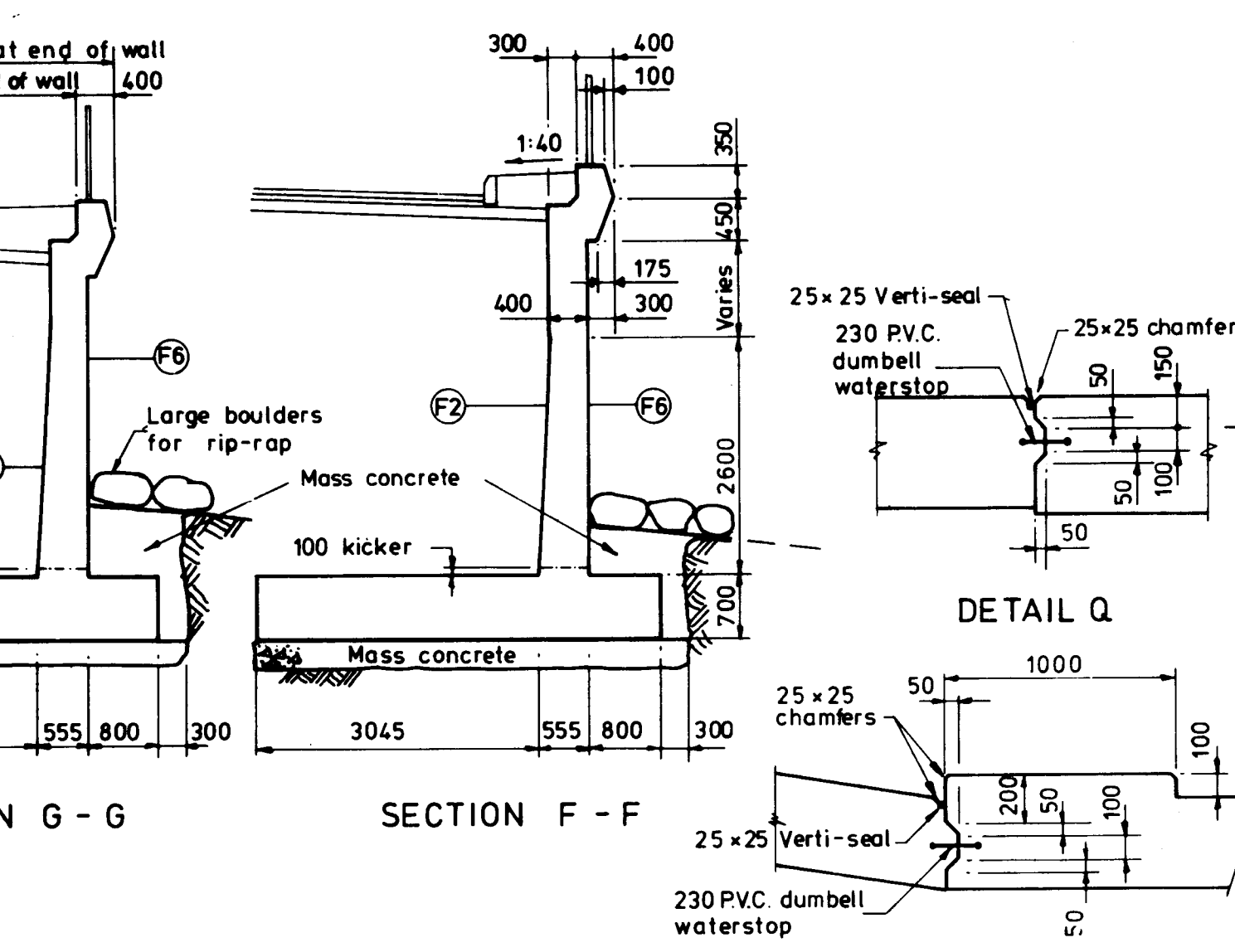

SECTION G-G

SECTION F-F

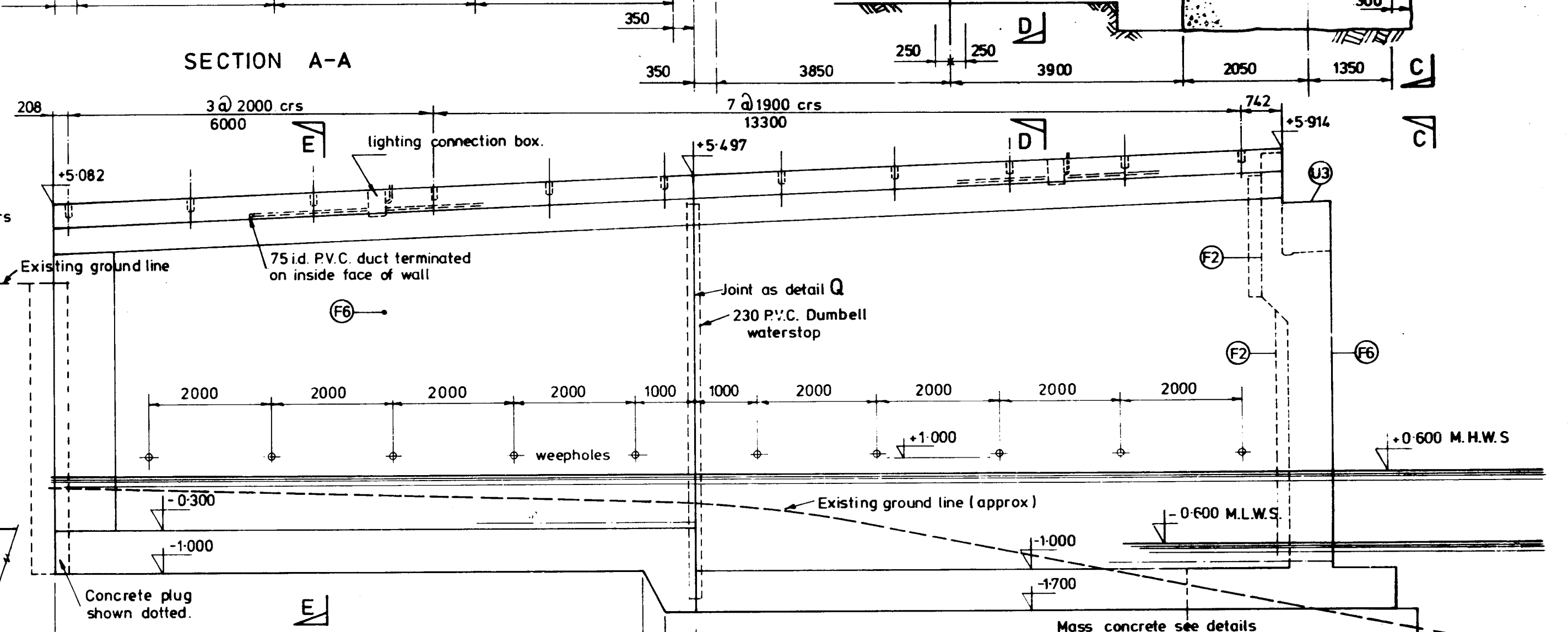

SECTION P-P

ELEVATION B-B

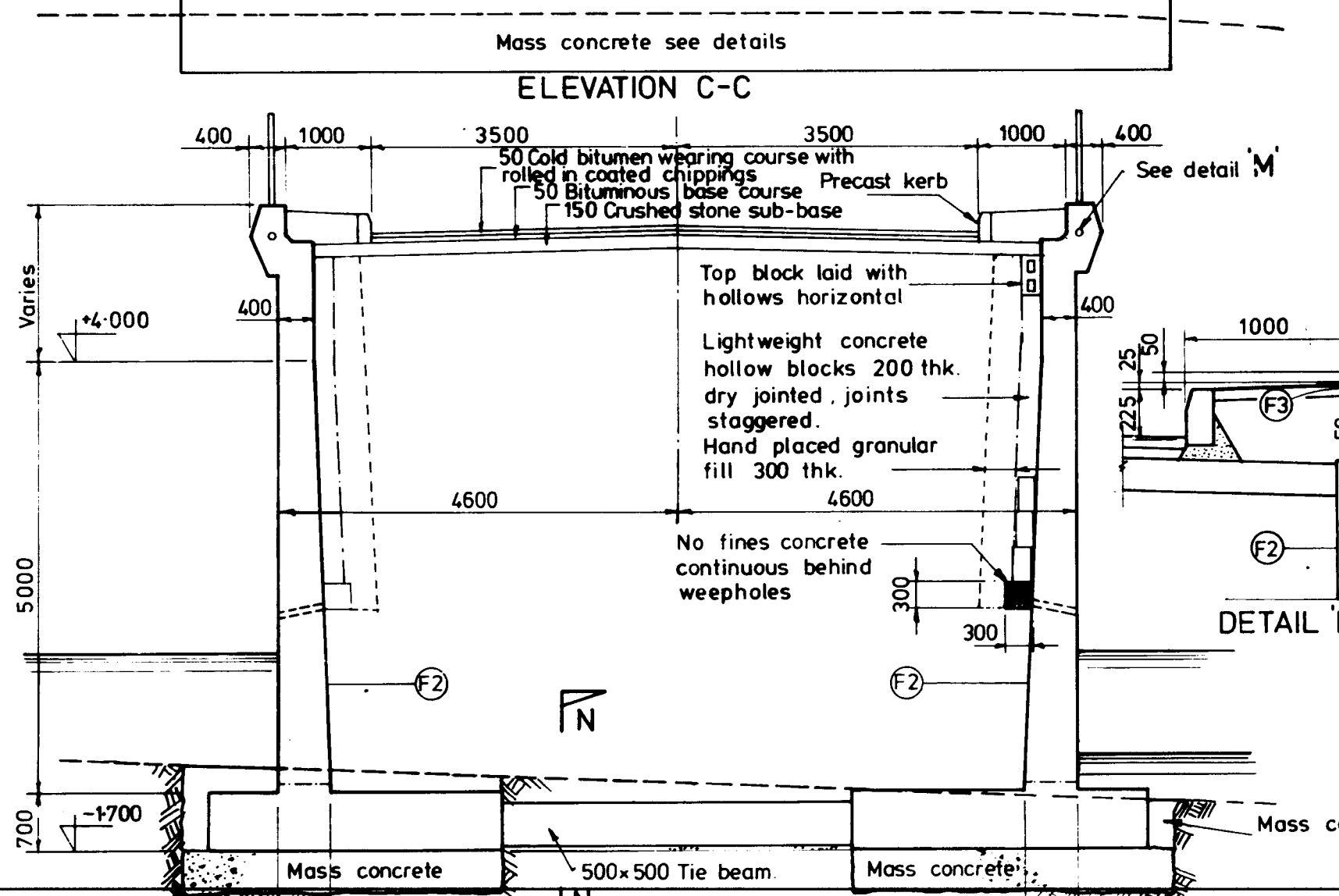

SECTION D-D

SECTION E-E

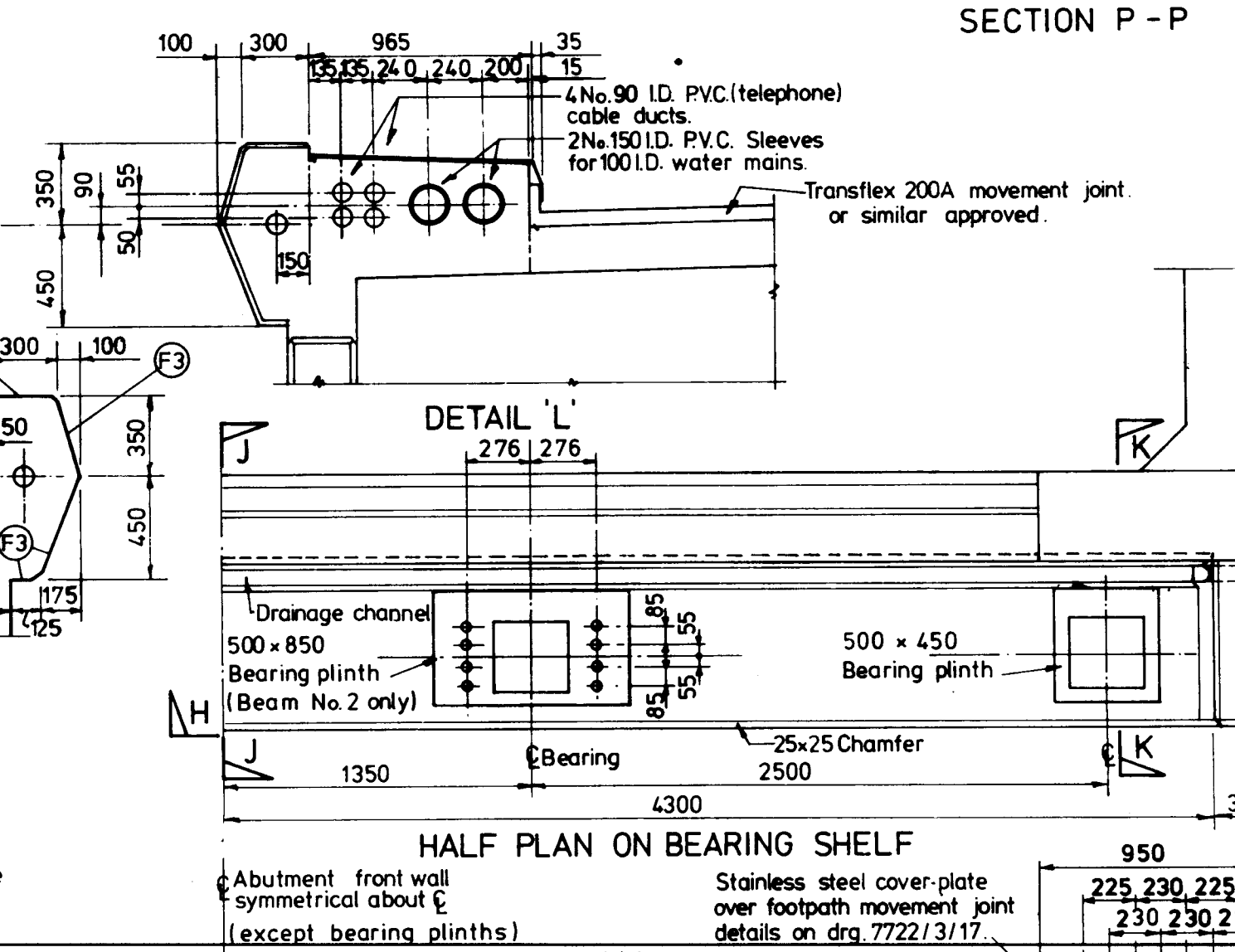

DETAIL L

HALF PLAN ON BEARING SHELF

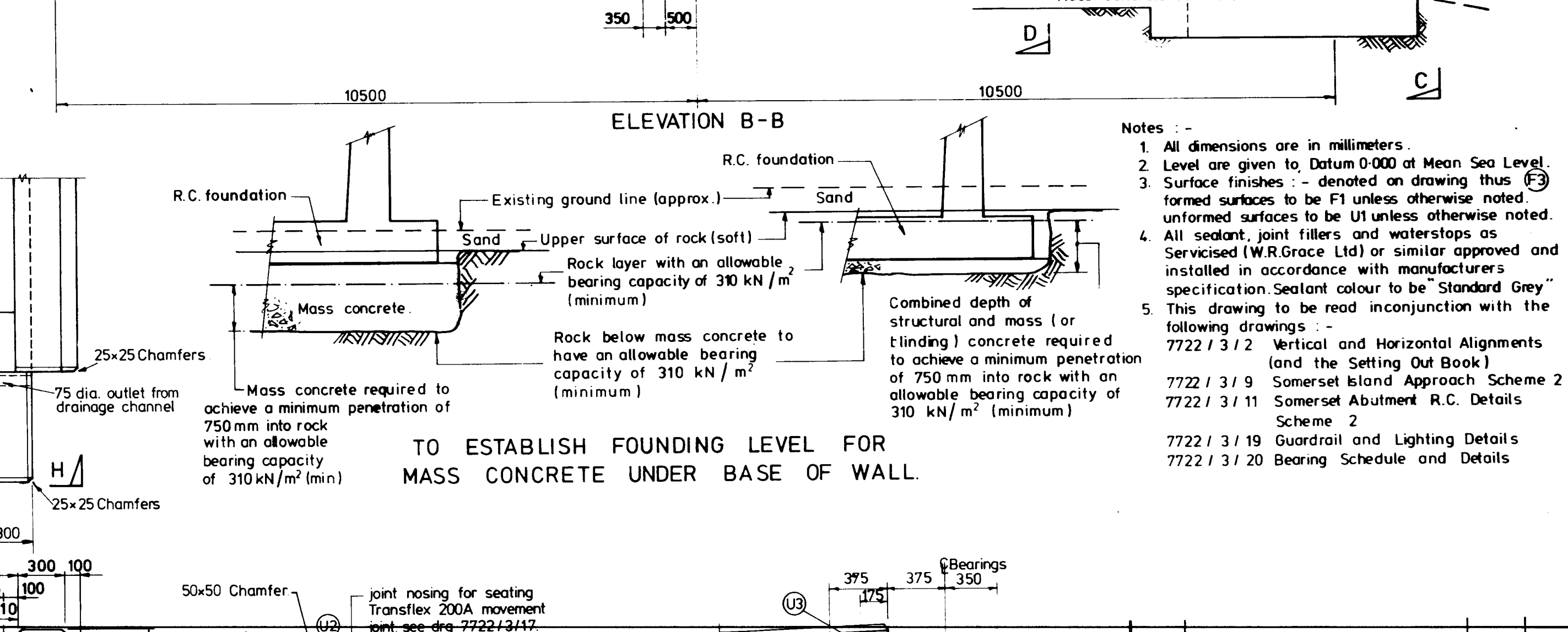

DETAIL M

SECTION J-J

SECTION K-K

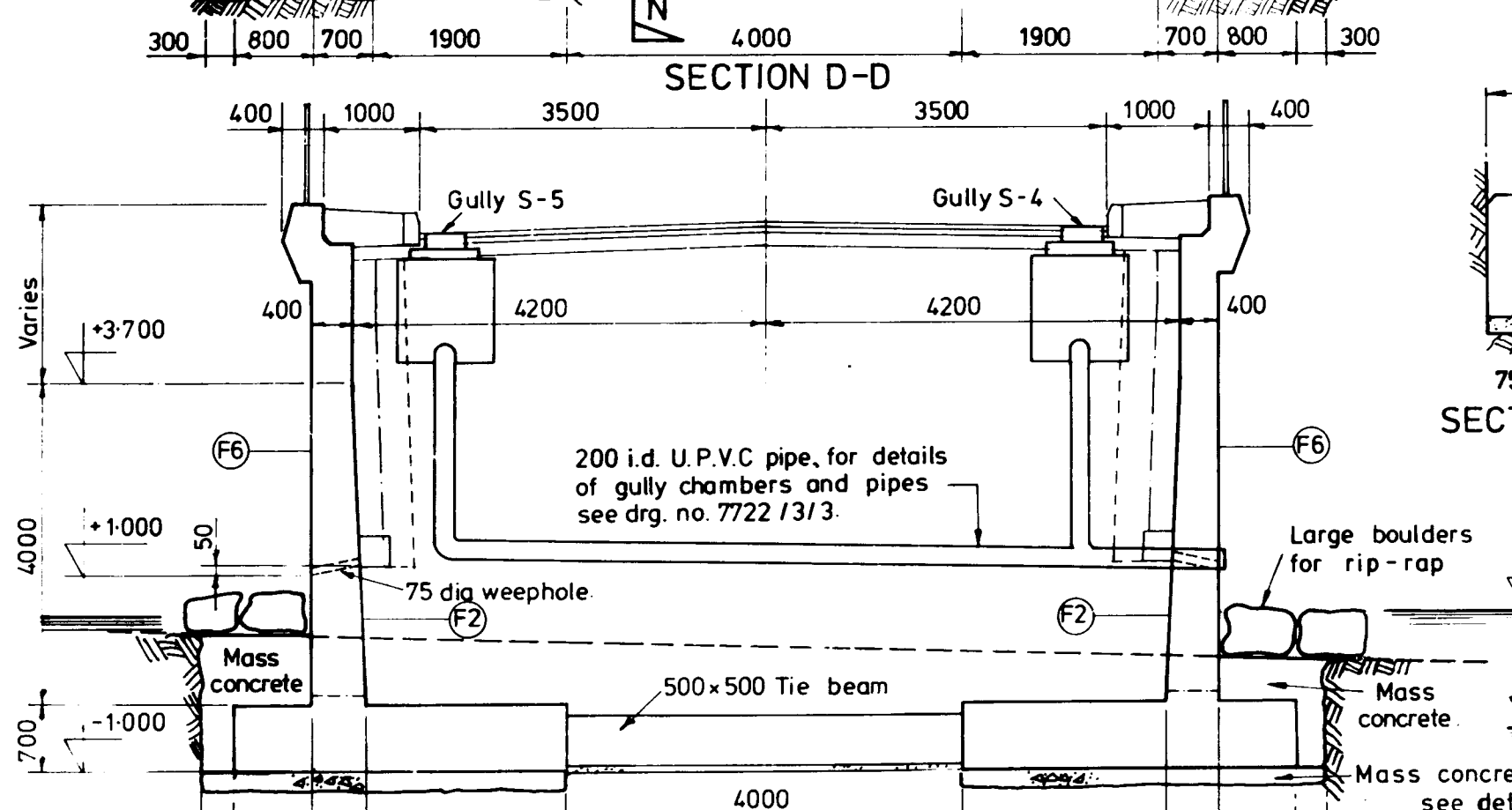

SECTION N-N

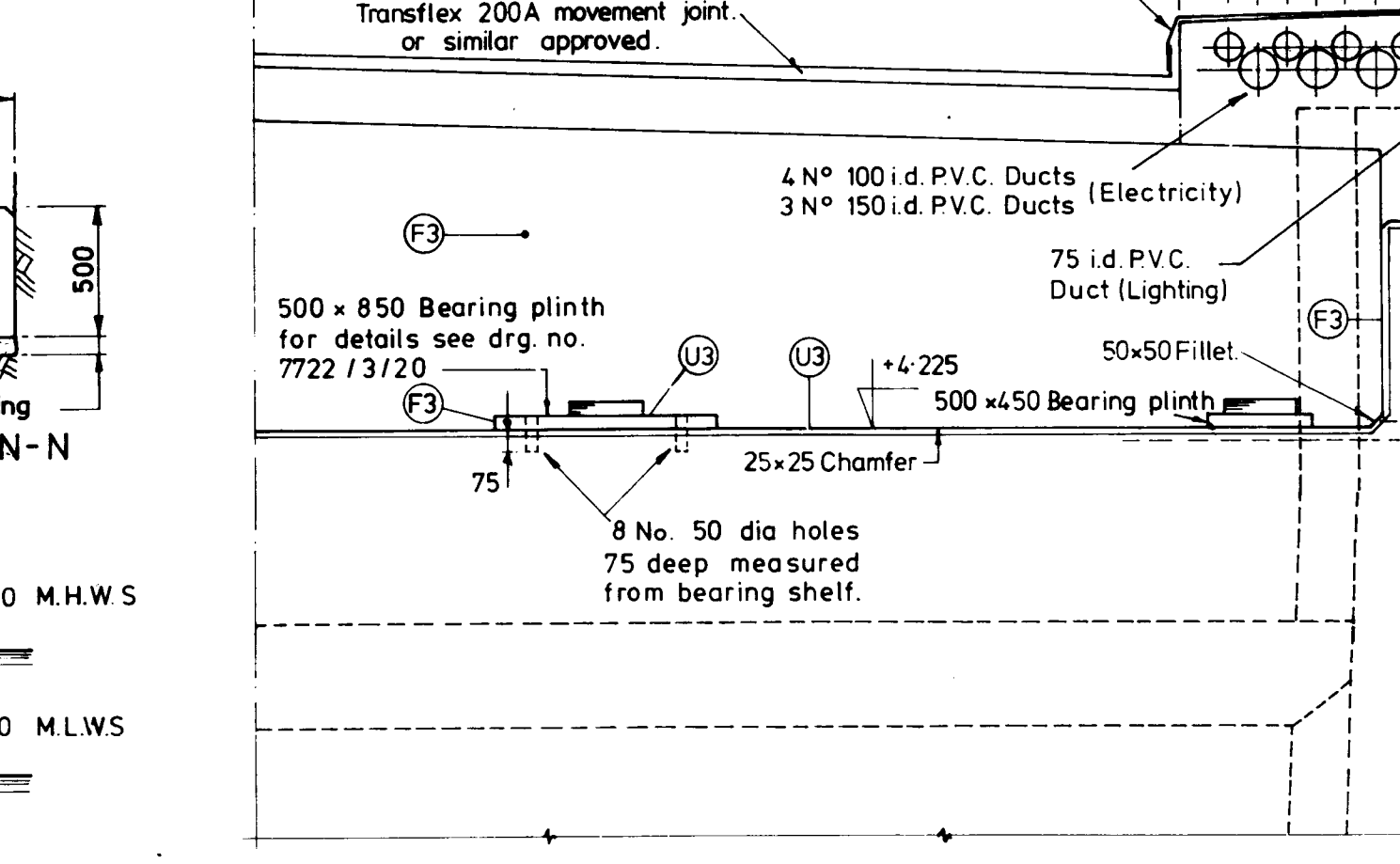

ELEVATION H-H

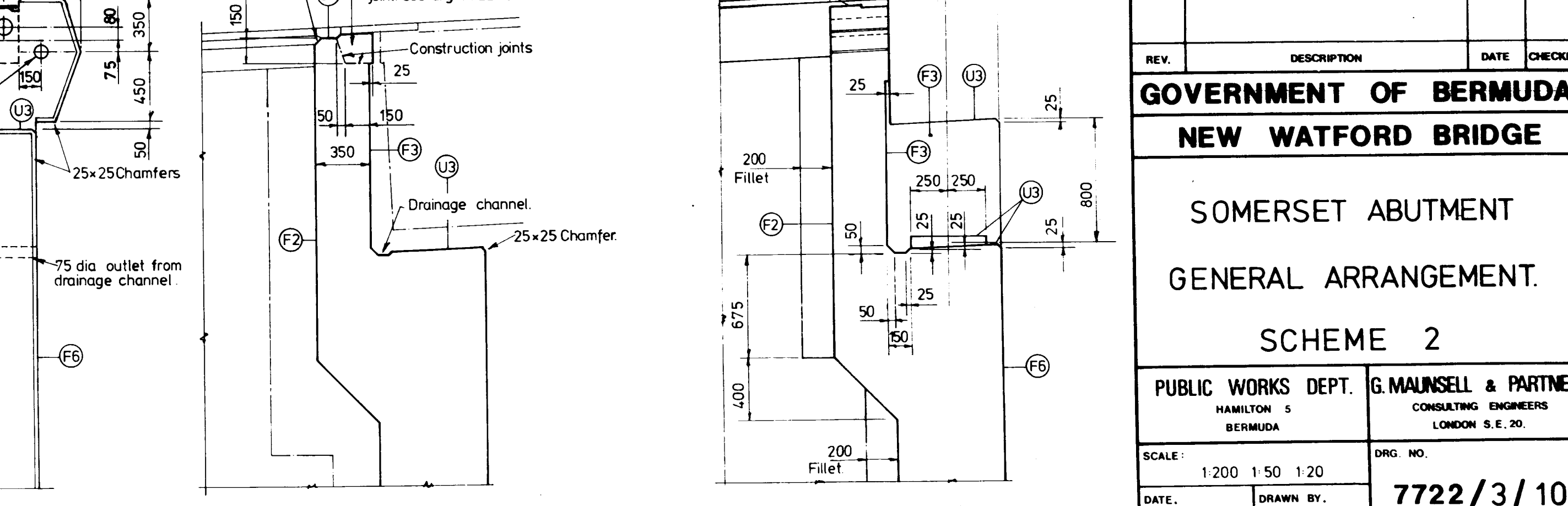

- Notes :-
- All dimensions are in millimeters.
 - Level are given to Datum 0.000 at Mean Sea Level.
 - Surface finishes :- denoted on drawing thus (F3) formed surfaces to be F1 unless otherwise noted. unformed surfaces to be U1 unless otherwise noted.
 - All sealant, joint fillers and waterstops as Serviced (W.R. Grace Ltd) or similar approved and installed in accordance with manufacturers specification. Sealant colour to be "Standard Grey".
 - This drawing is to be read in conjunction with the following drawings :-
 - 7722/3/2 Vertical and Horizontal Alignments (and the Setting Out Book)
 - 7722/3/9 Somerset Island Approach Scheme 2
 - 7722/3/11 Somerset Abutment R.C. Details Scheme 2
 - 7722/3/19 Guardrail and Lighting Details
 - 7722/3/20 Bearing Schedule and Details

TO ESTABLISH FOUNDING LEVEL FOR MASS CONCRETE UNDER BASE OF WALL.

REV.	DESCRIPTION	DATE	CHECKED
GOVERNMENT OF BERMUDA			
NEW WATFORD BRIDGE			
SOMERSET ABUTMENT			
GENERAL ARRANGEMENT.			
SCHEME 2			
PUBLIC WORKS DEPT. HAMILTON 5 BERMUDA		G. MAUNSELL & PARTNERS CONSULTING ENGINEERS LONDON S.E. 20.	
SCALE: 1:200 1:50 1:20		DRG. NO.	
DATE: MAY 1979		DRAWN BY: A.S.	
7722/3/10.			

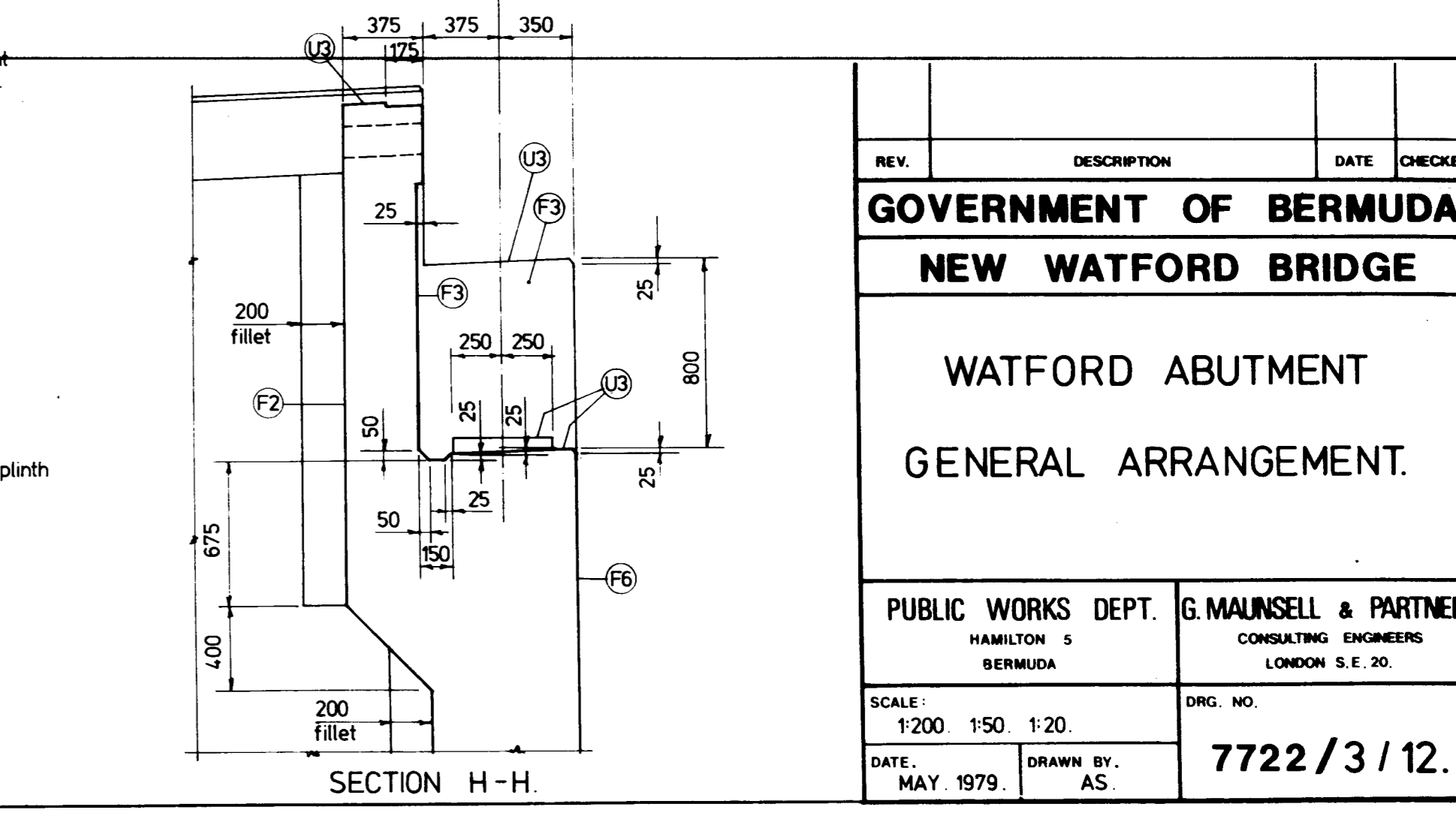
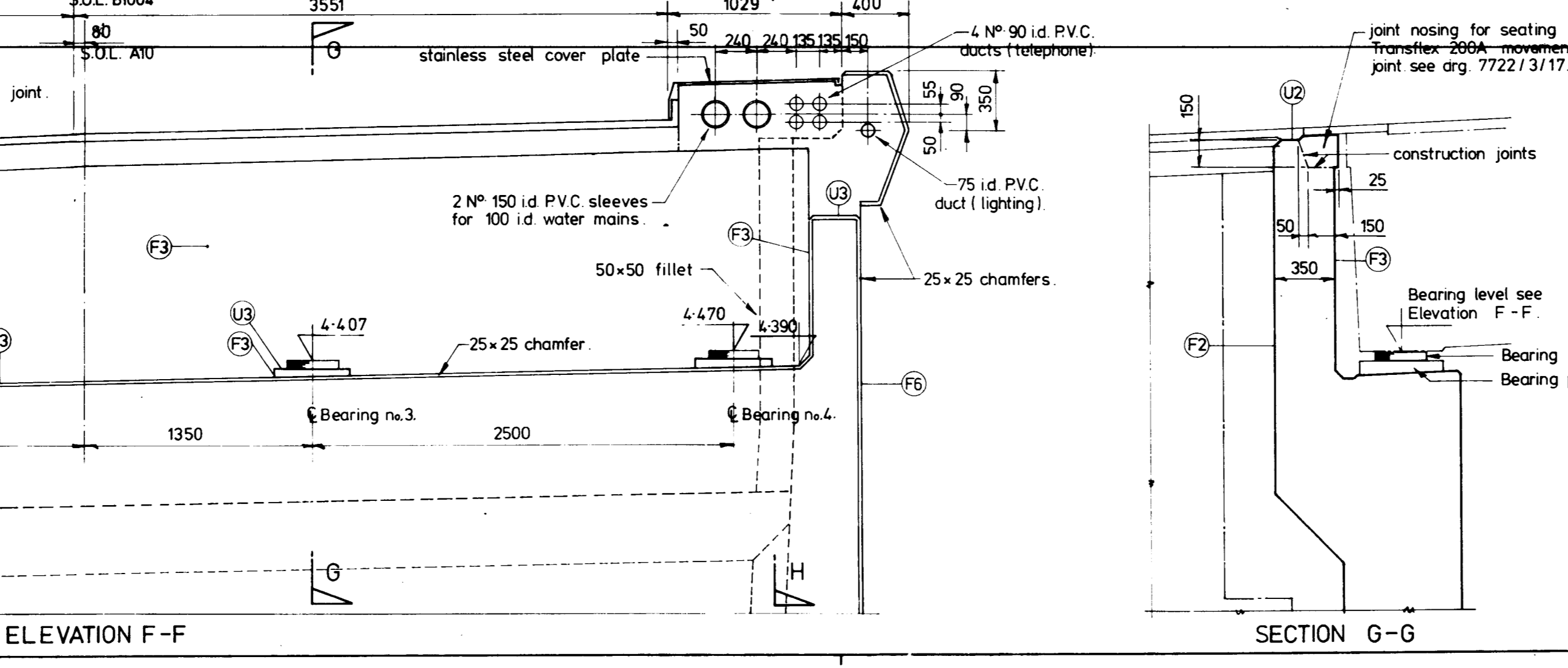
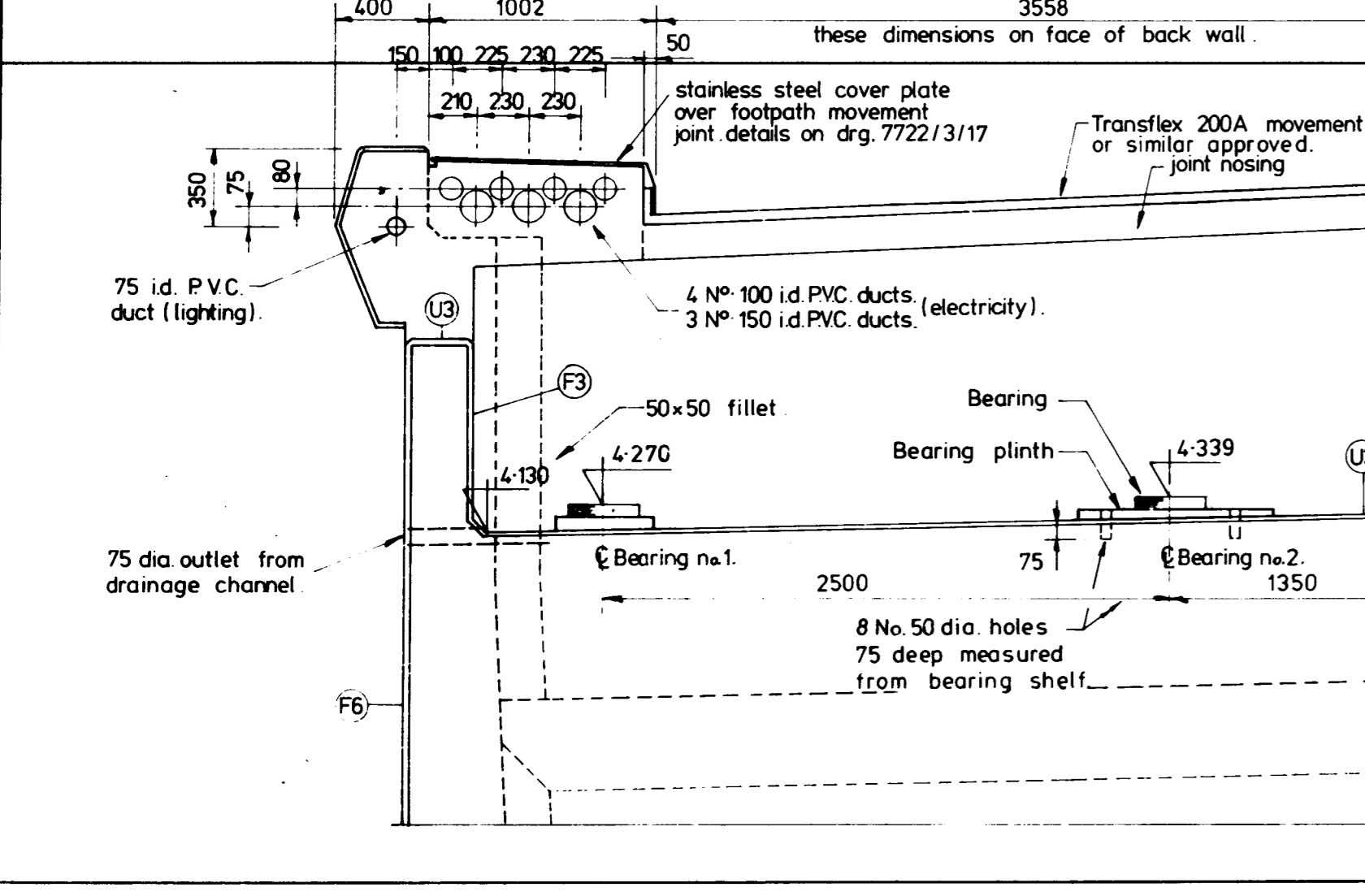
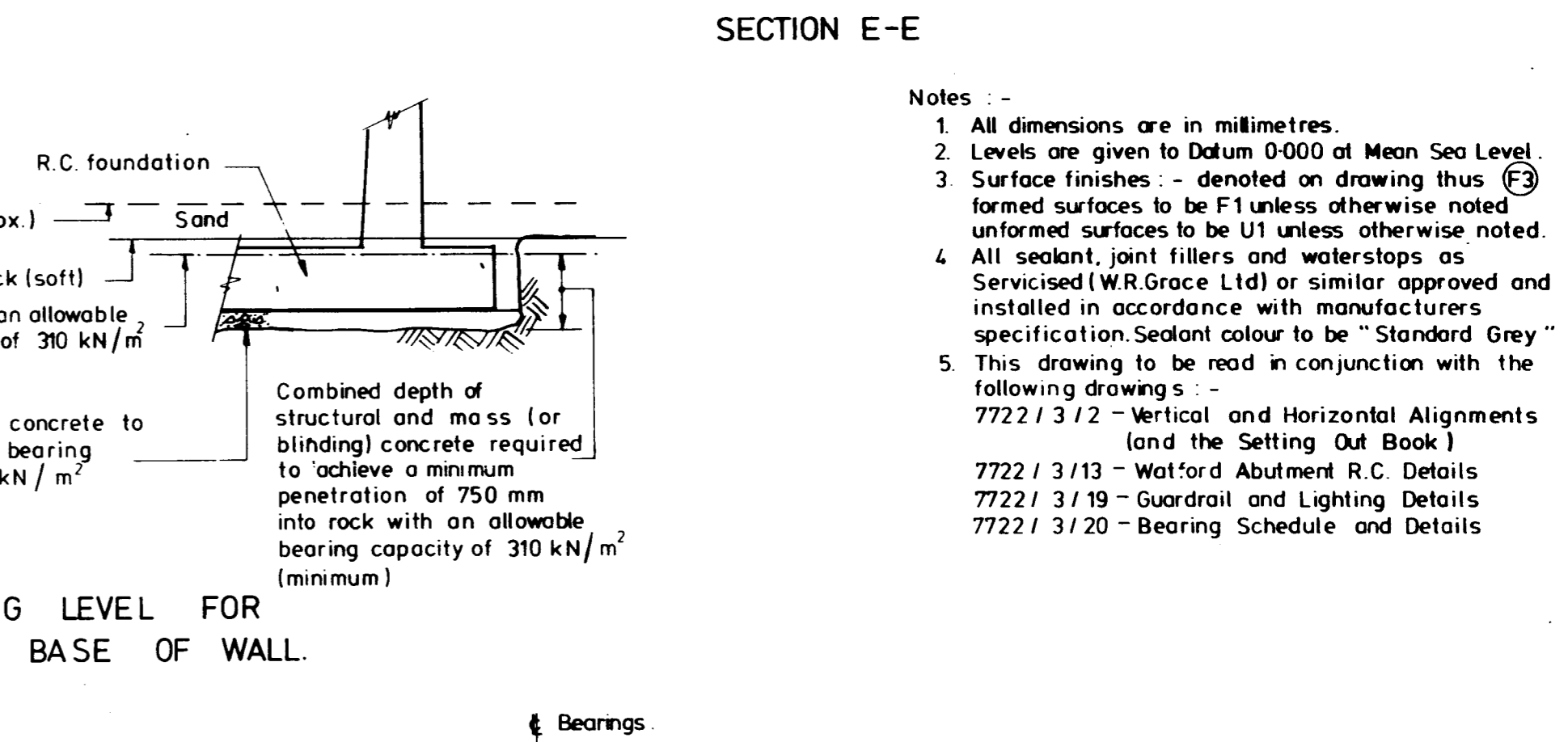
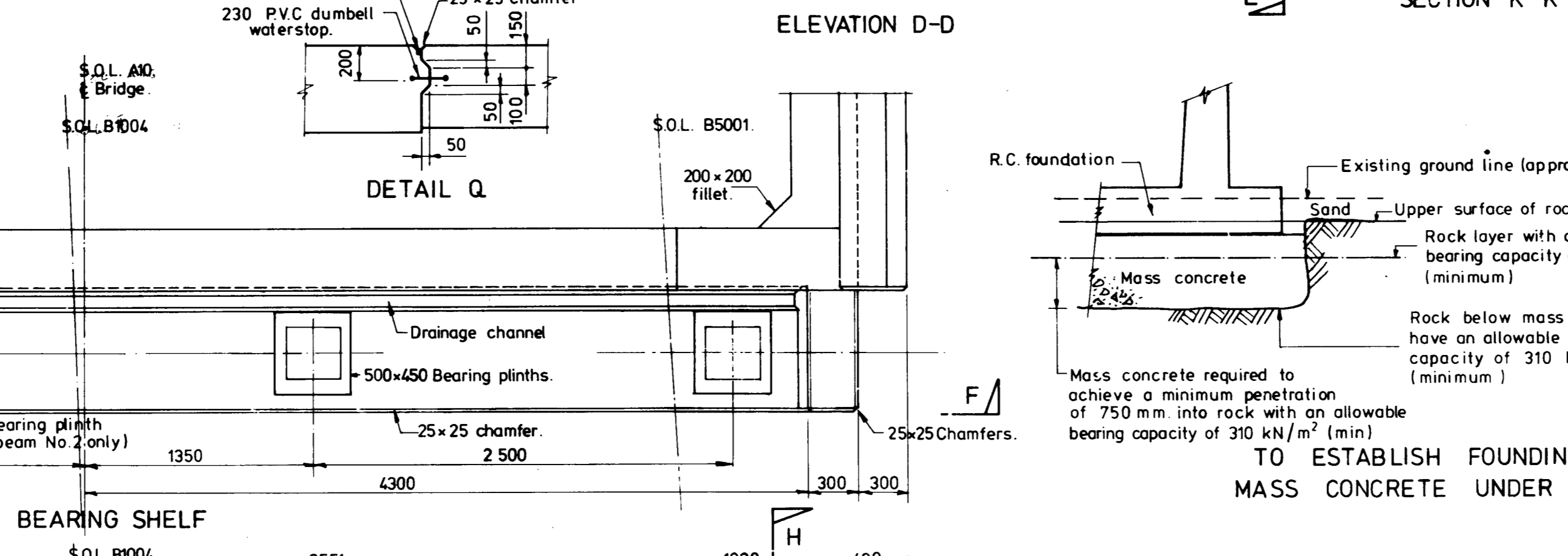
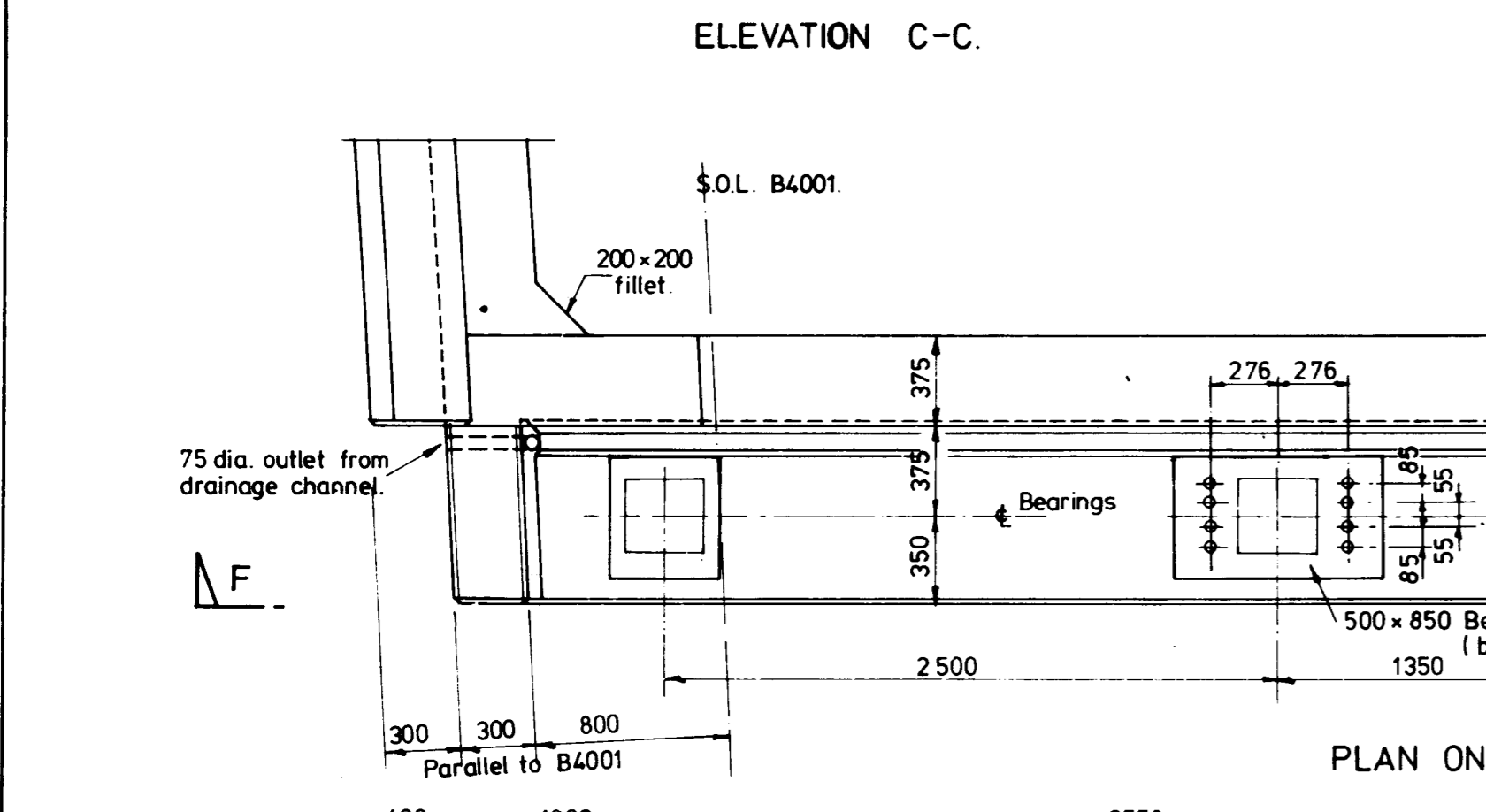
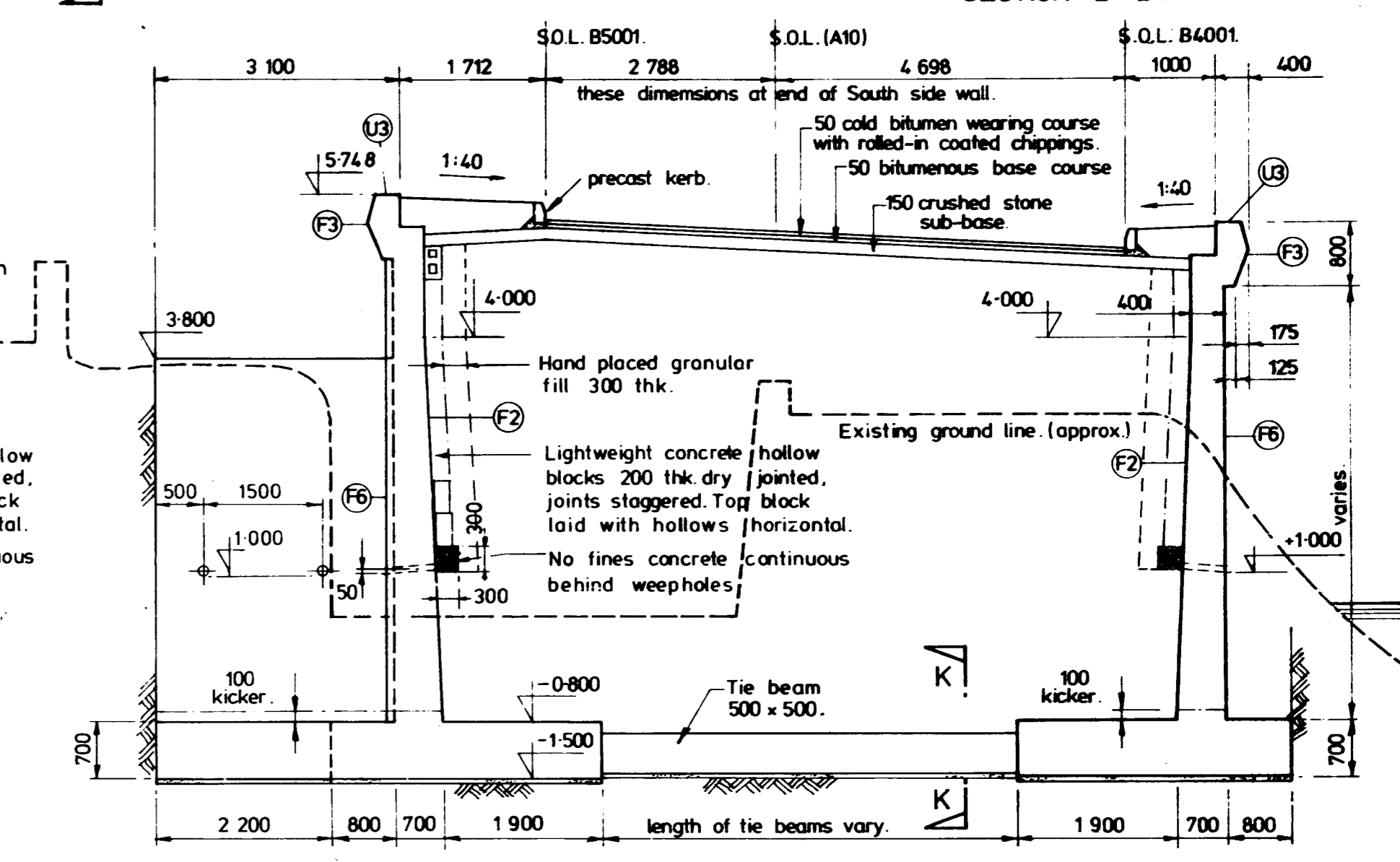
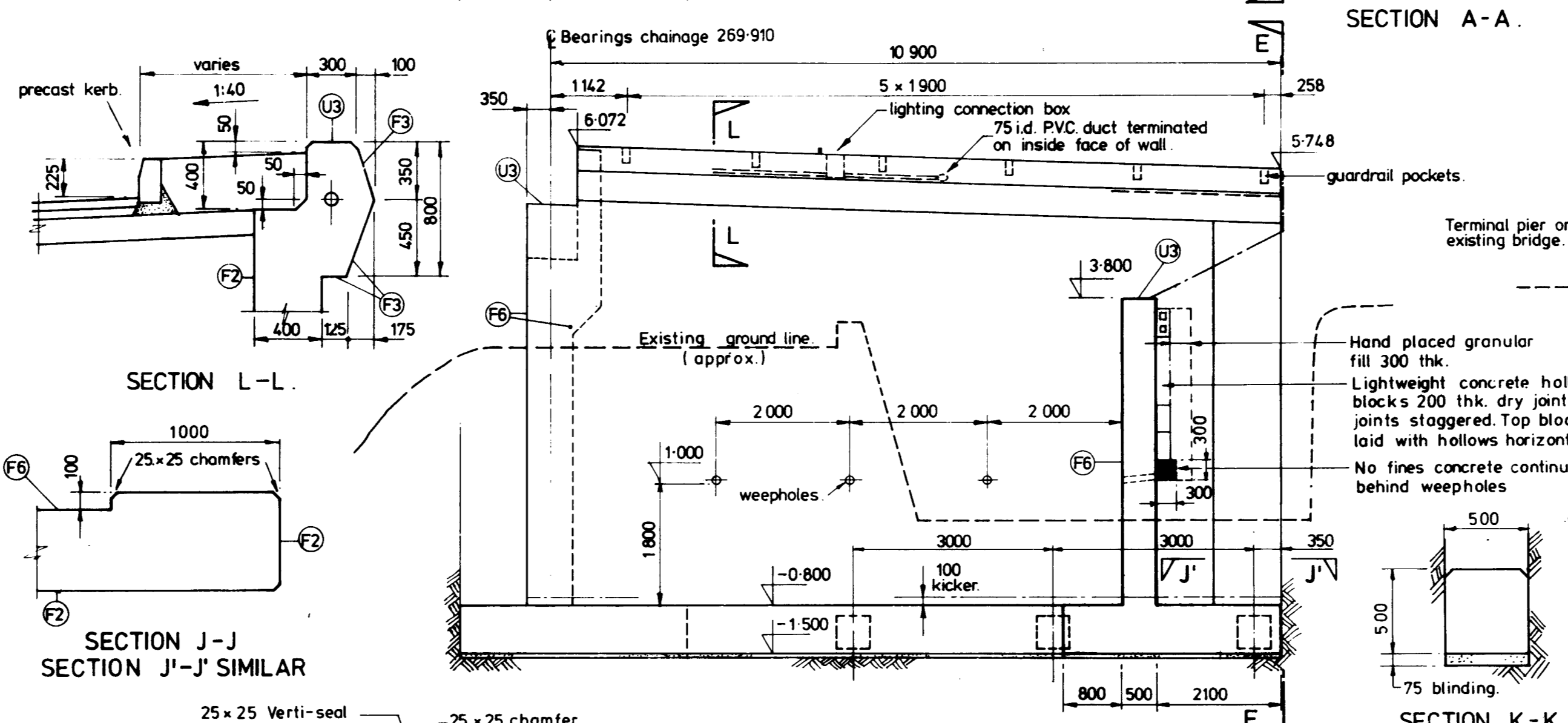
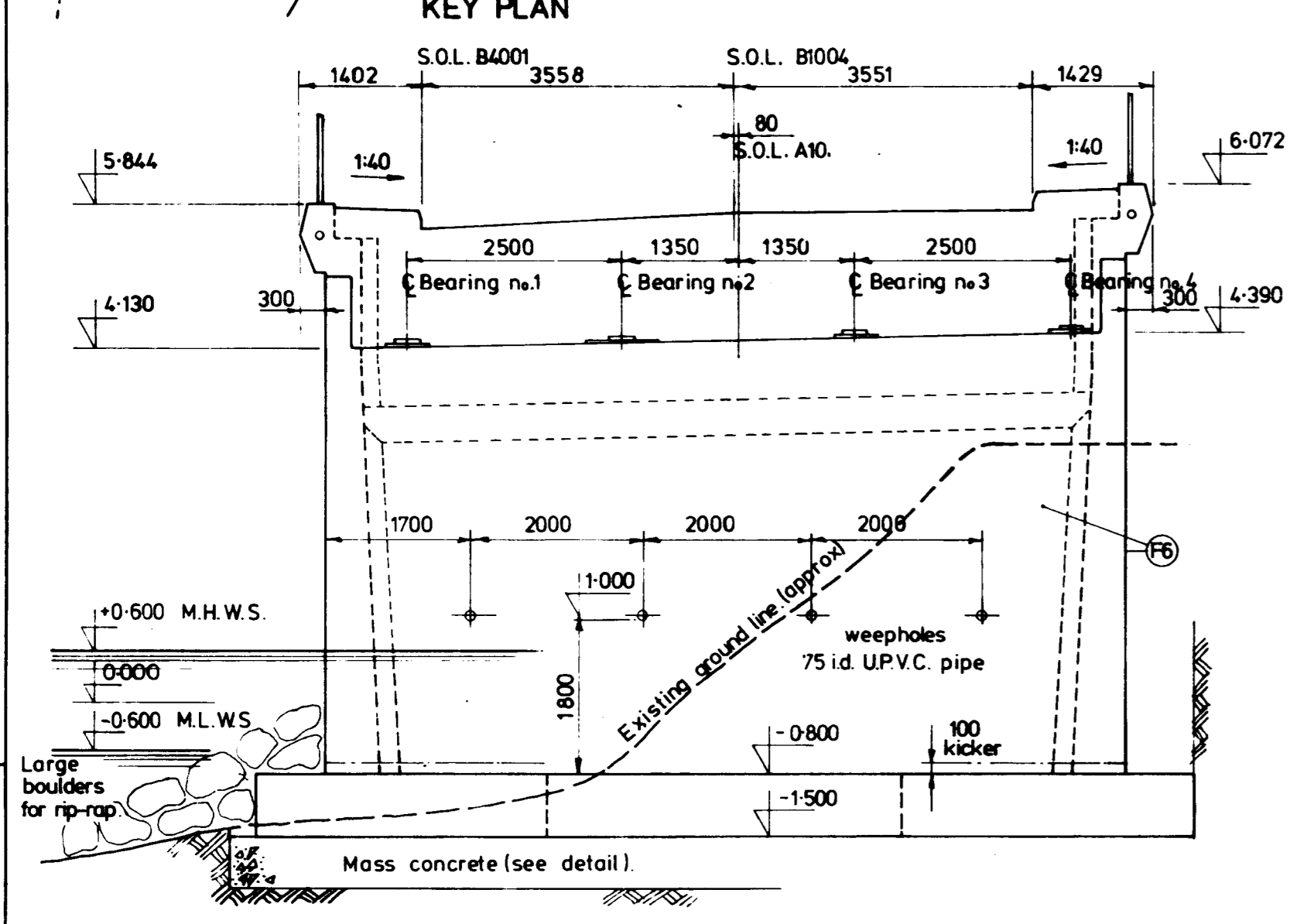
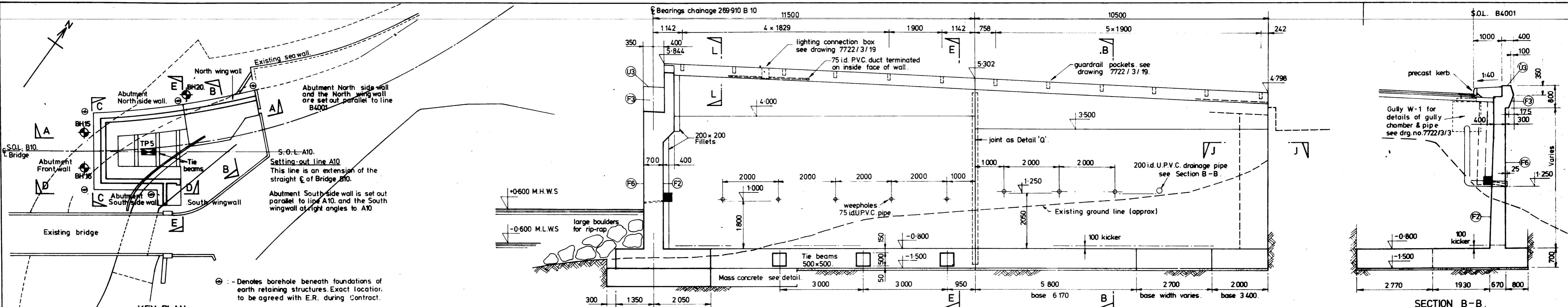

- Notes :-
1. All dimensions are in millimetres.
 2. Levels are given to Datum 0-000 of Mean Sea Level.
 3. Surface finishes :- denoted on drawing thus (F3) formed surfaces to be F1 unless otherwise noted. All sealant, joint fillers and waterstops as Serviced (W.R. Grace Ltd) or similar approved and installed in accordance with manufacturers specification. Sealant colour to be "Standard Grey".
 4. This drawing to be read in conjunction with the following drawings :- 7722/3/12 - Vertical and Horizontal Alignments (and the Setting Out Book) 7722/3/13 - Watford Abutment R.C. Details 7722/3/19 - Guardrail and Lighting Details 7722/3/20 - Bearing Schedule and Details

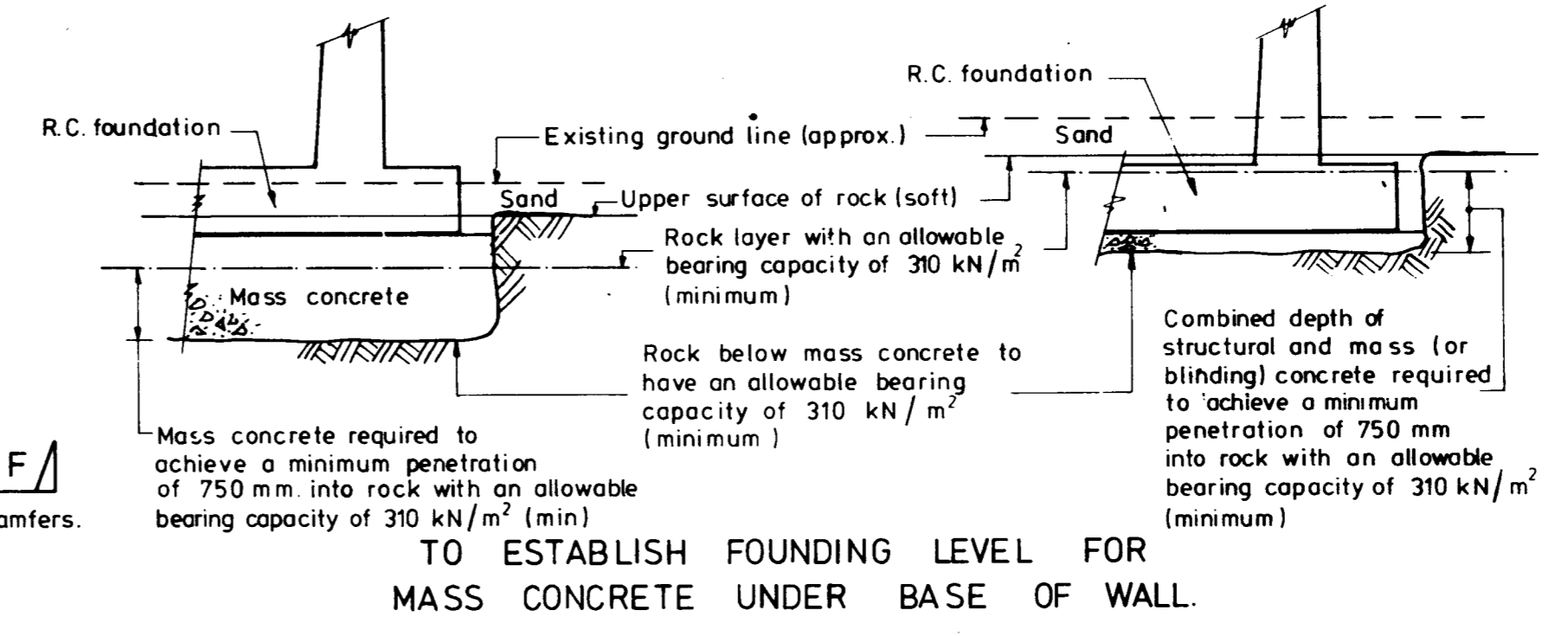

REV.	DESCRIPTION	DATE	CHECKED
GOVERNMENT OF BERMUDA			
NEW WATFORD BRIDGE			
WATFORD ABUTMENT			
GENERAL ARRANGEMENT.			
PUBLIC WORKS DEPT. HAMILTON 5 BERMUDA		G. MAUNSELL & PARTNERS CONSULTING ENGINEERS LONDON S.E. 20.	
SCALE: 1:200 1:50 1:20.	DATE: MAY 1979.		DRG. NO. 7722/3/12.

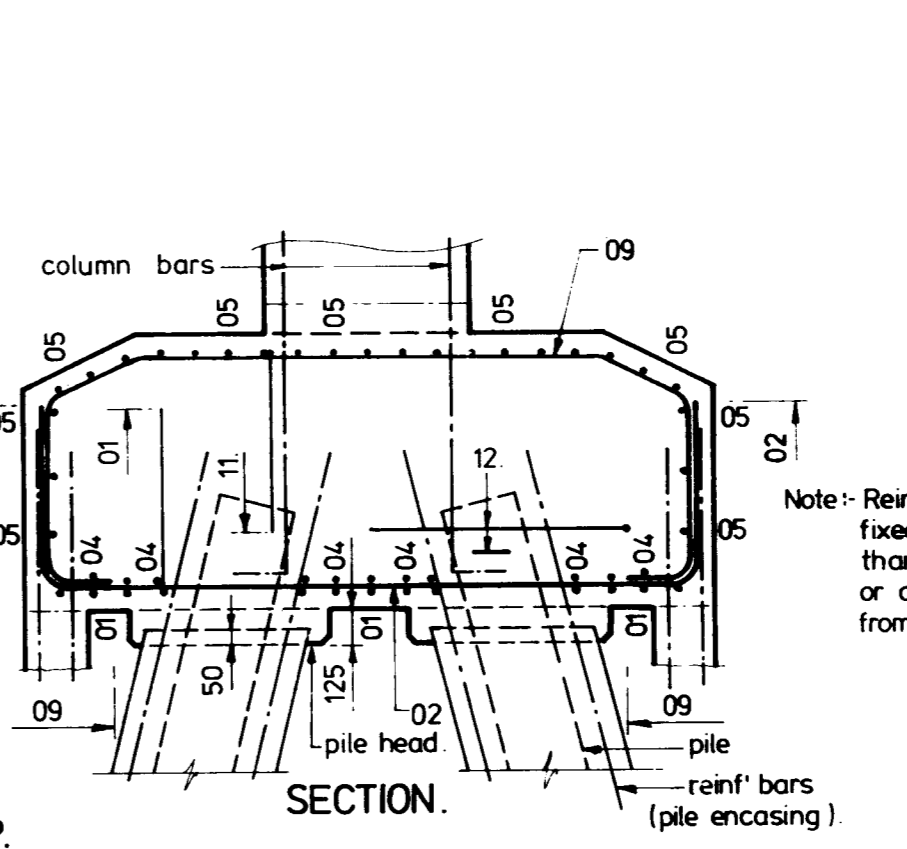
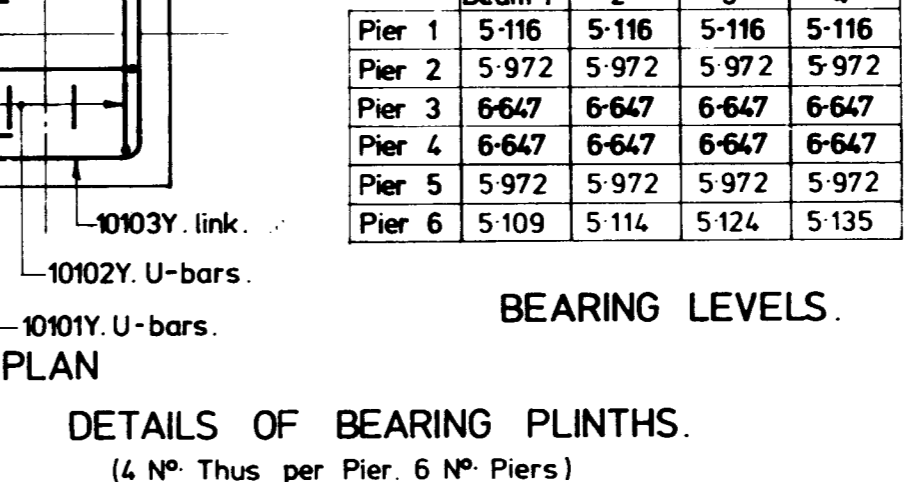
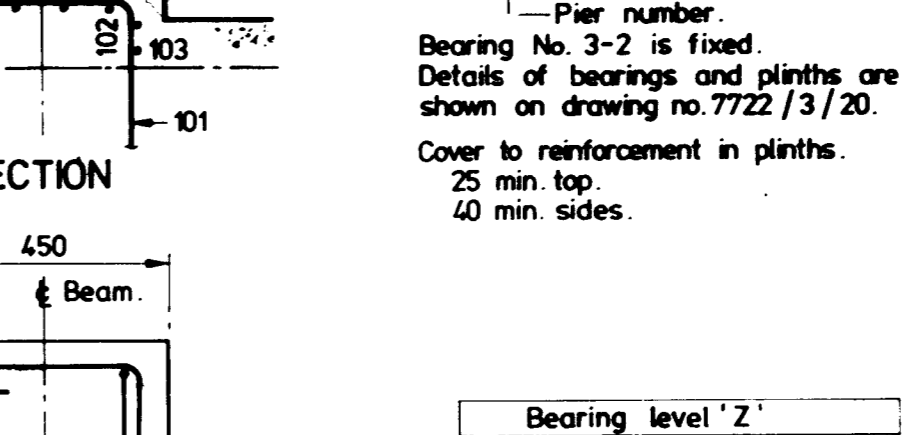
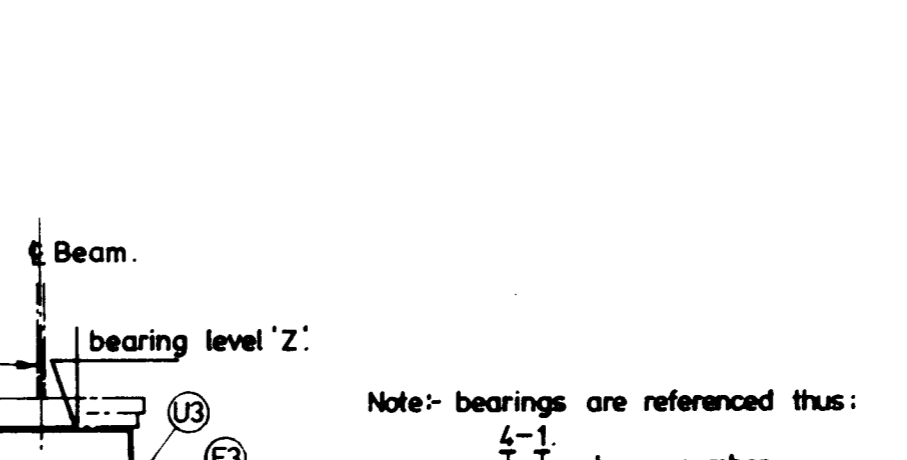
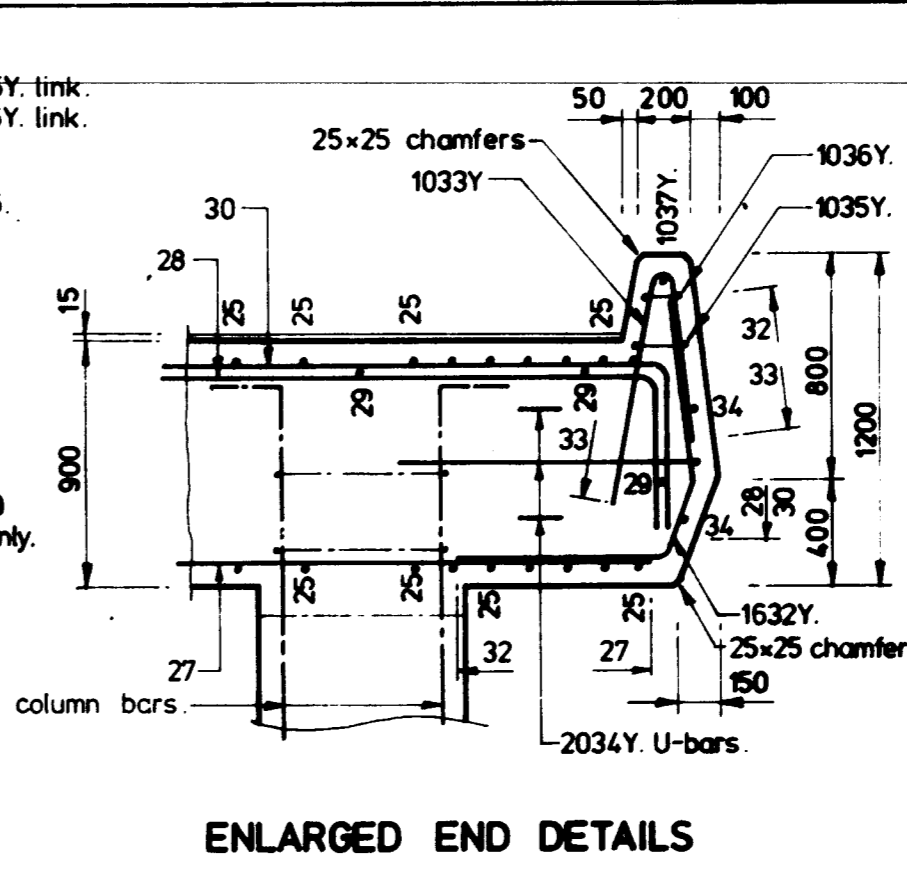
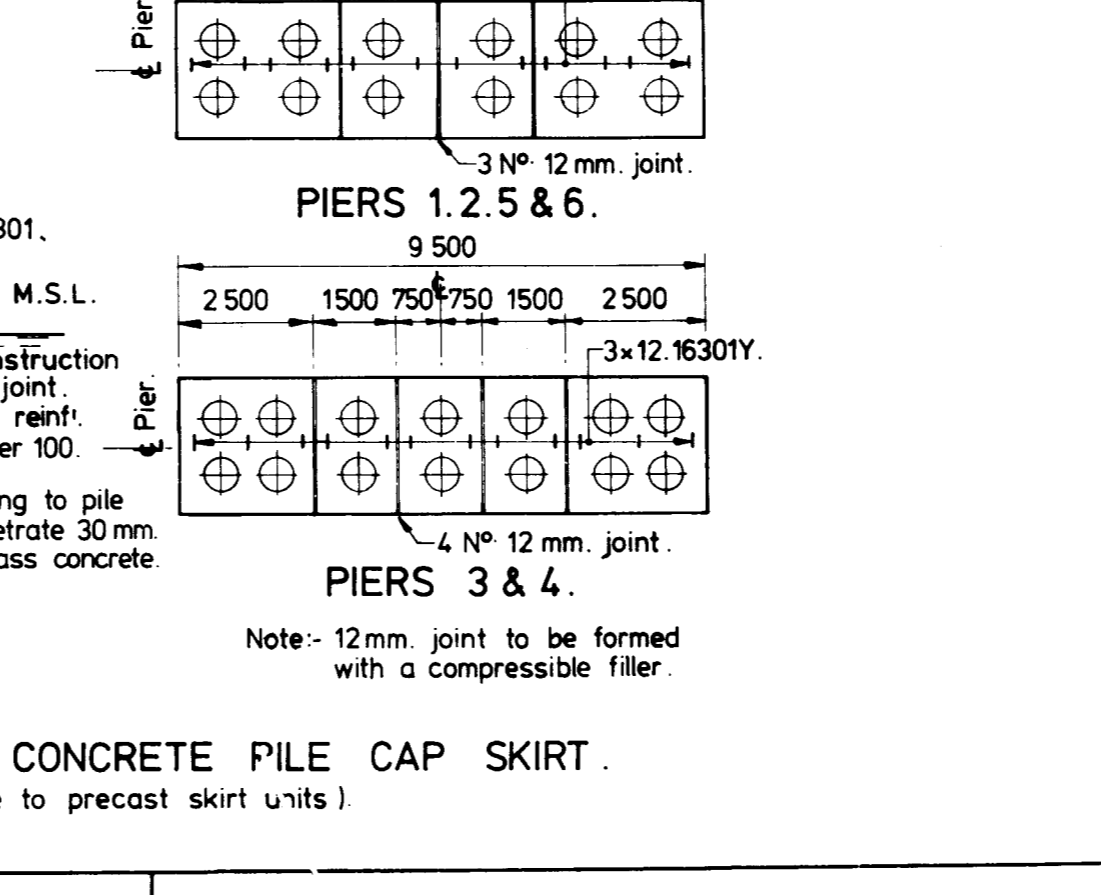
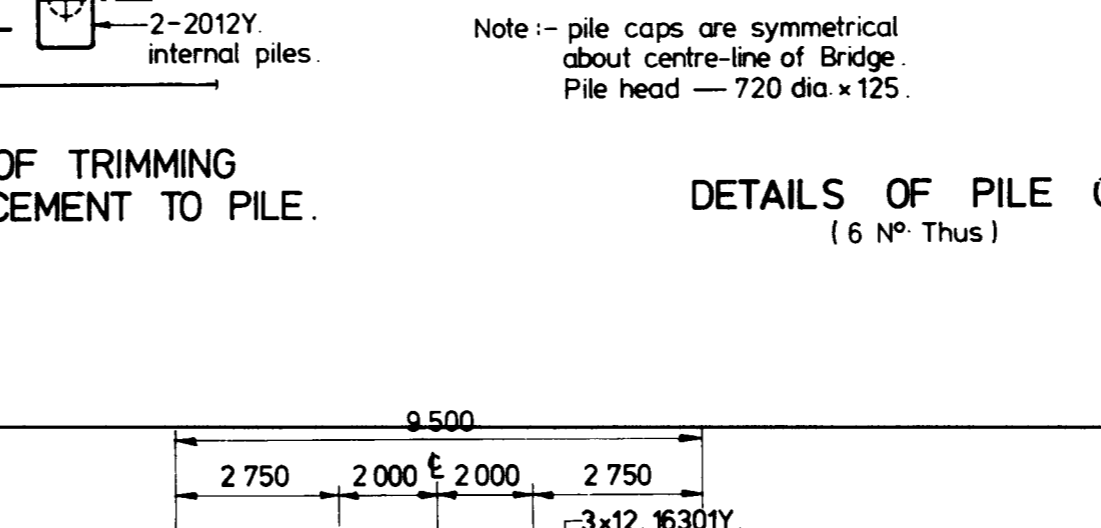
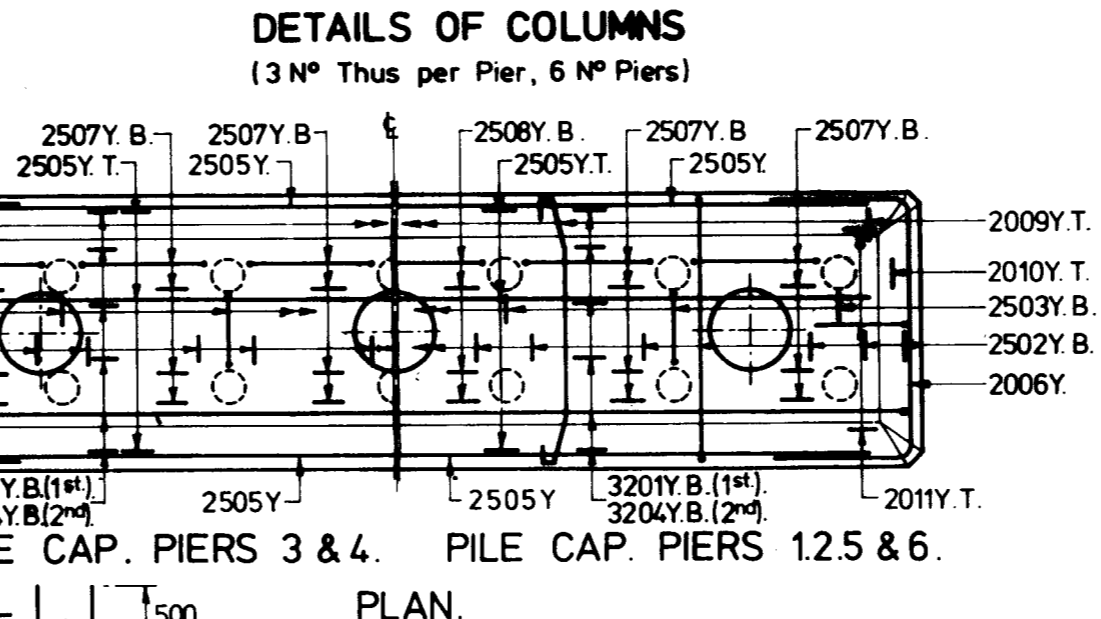
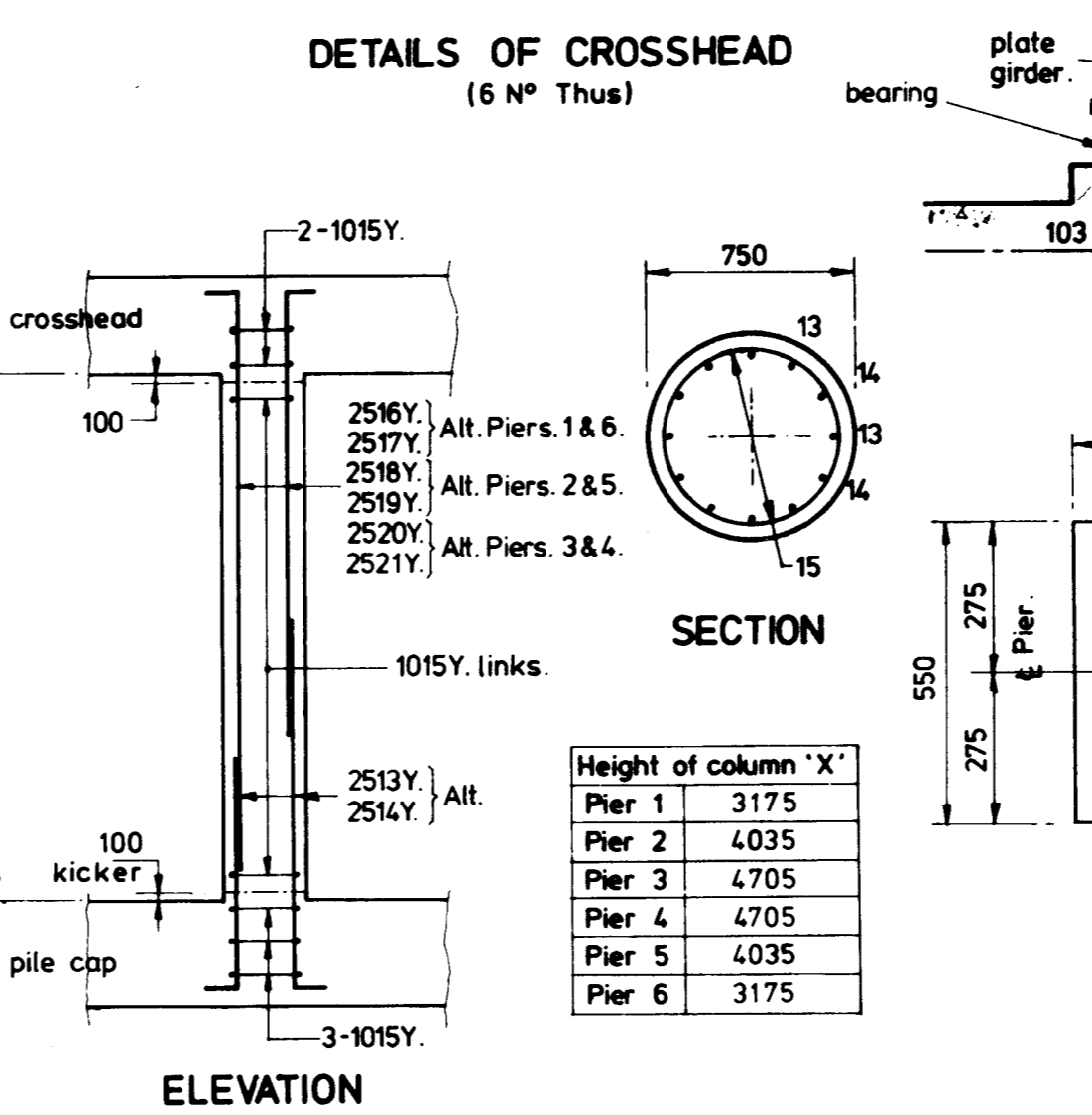
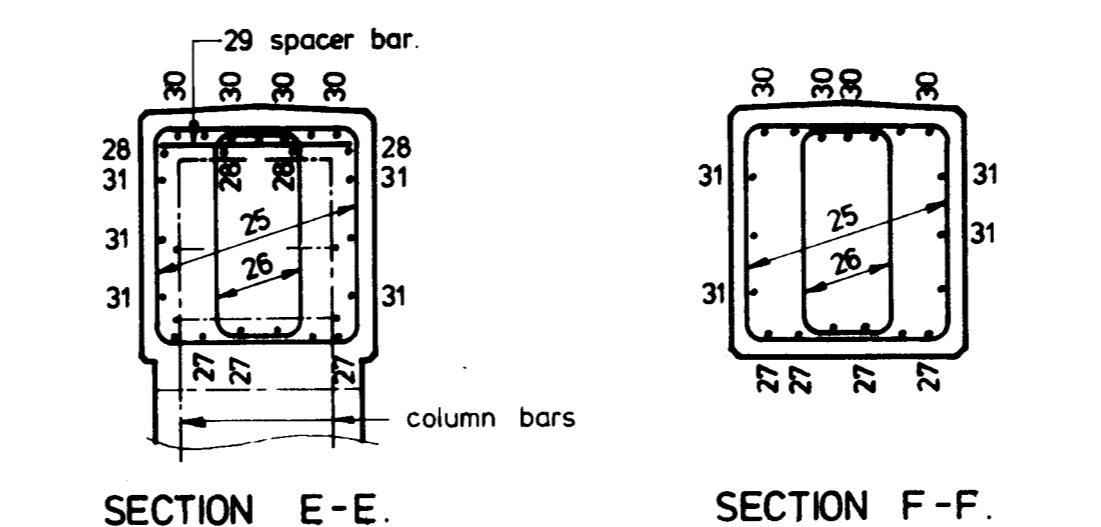
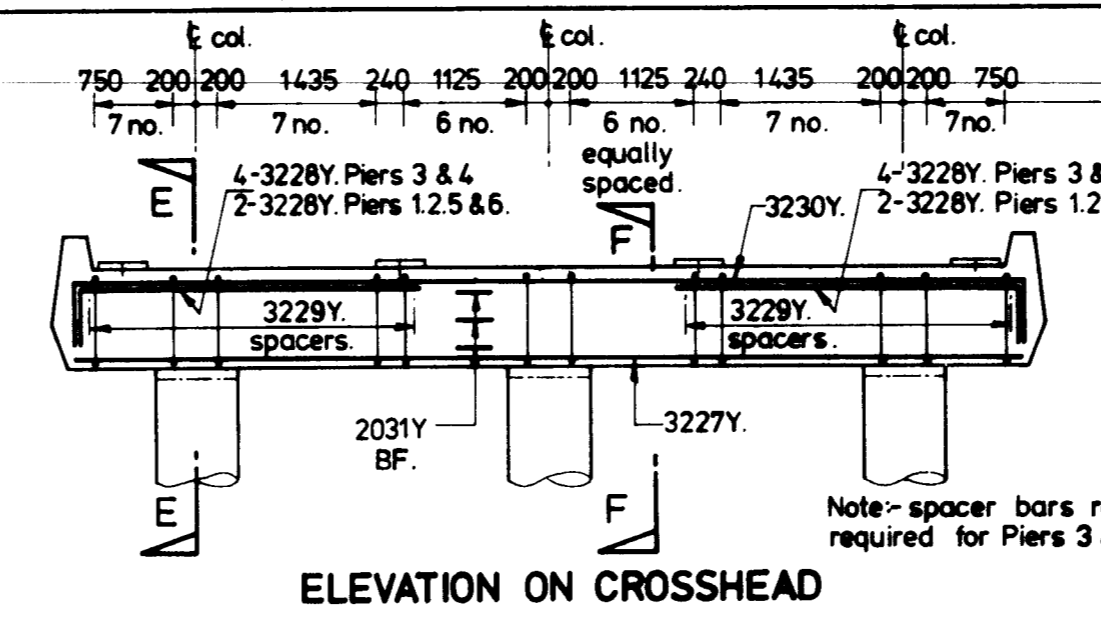
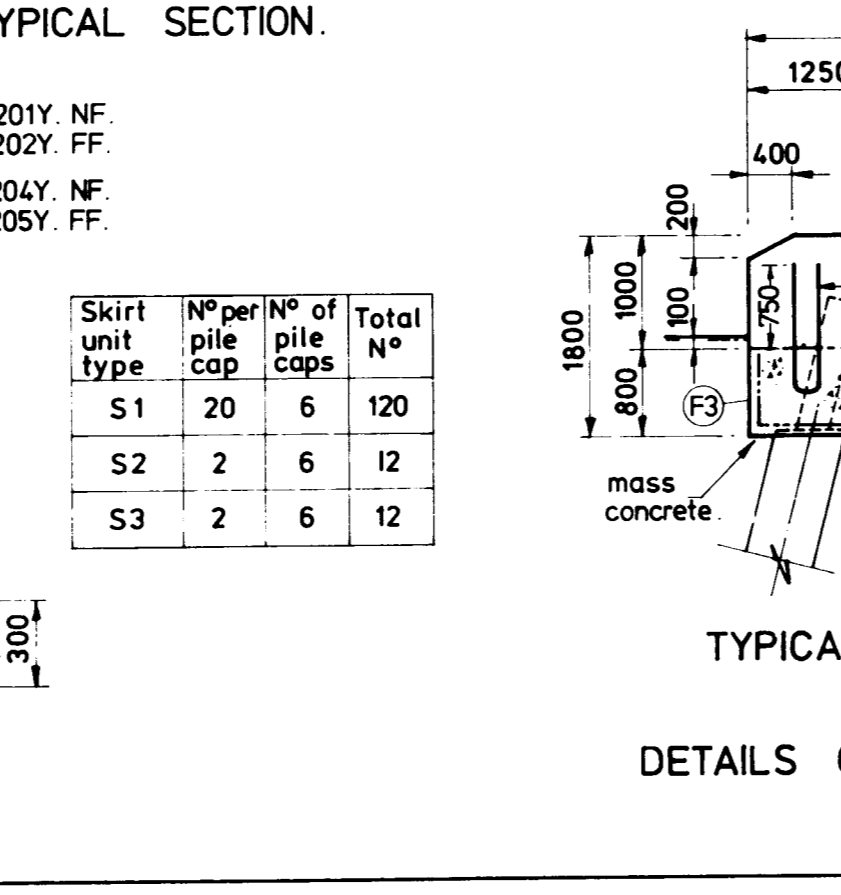
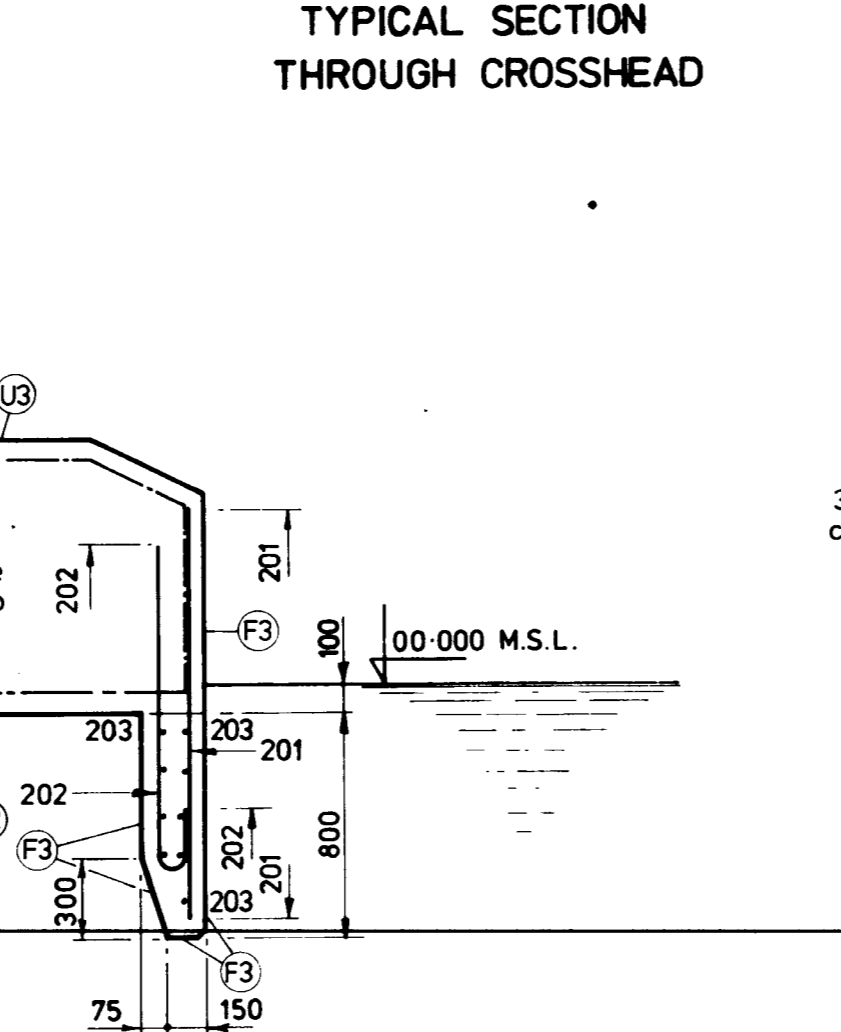
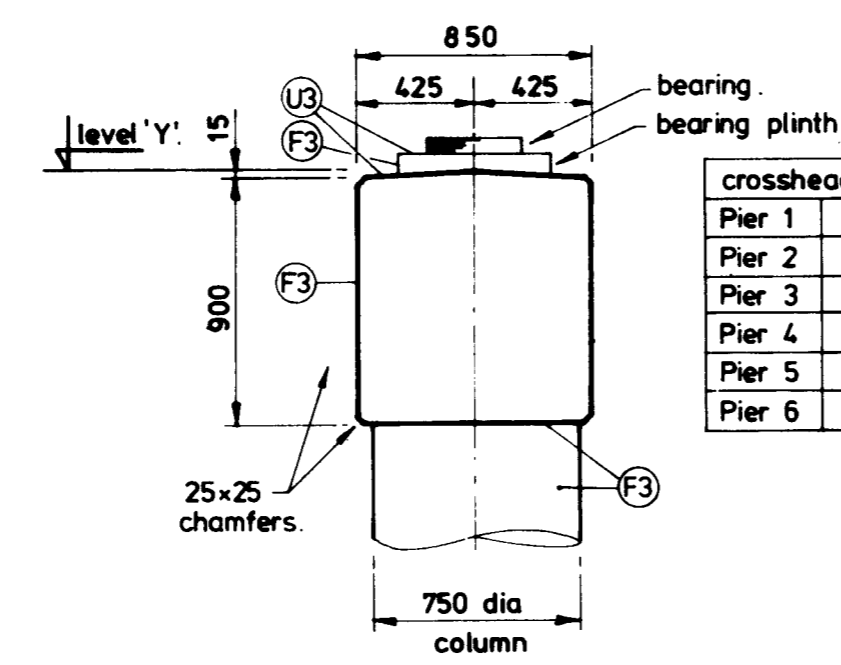
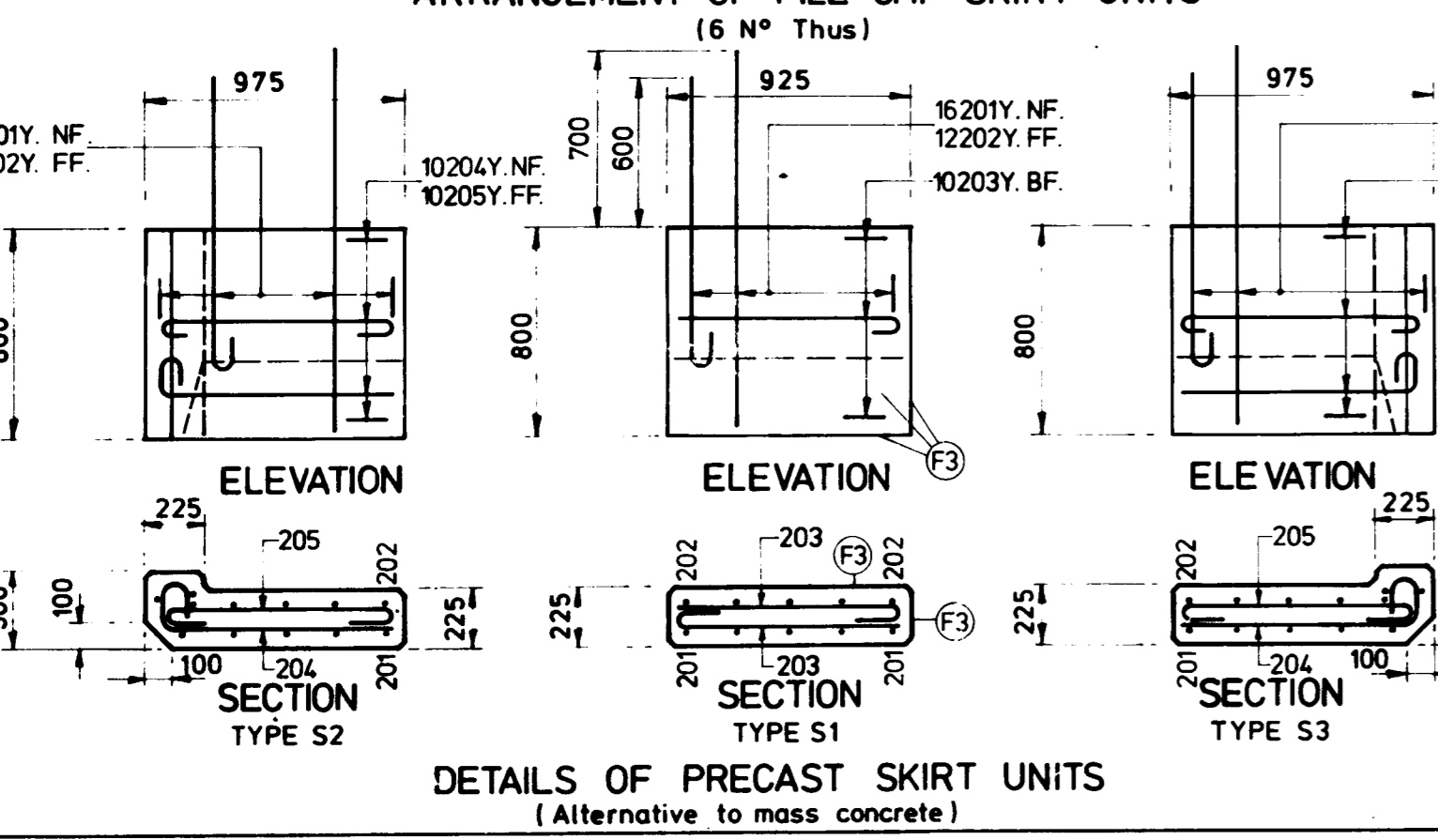
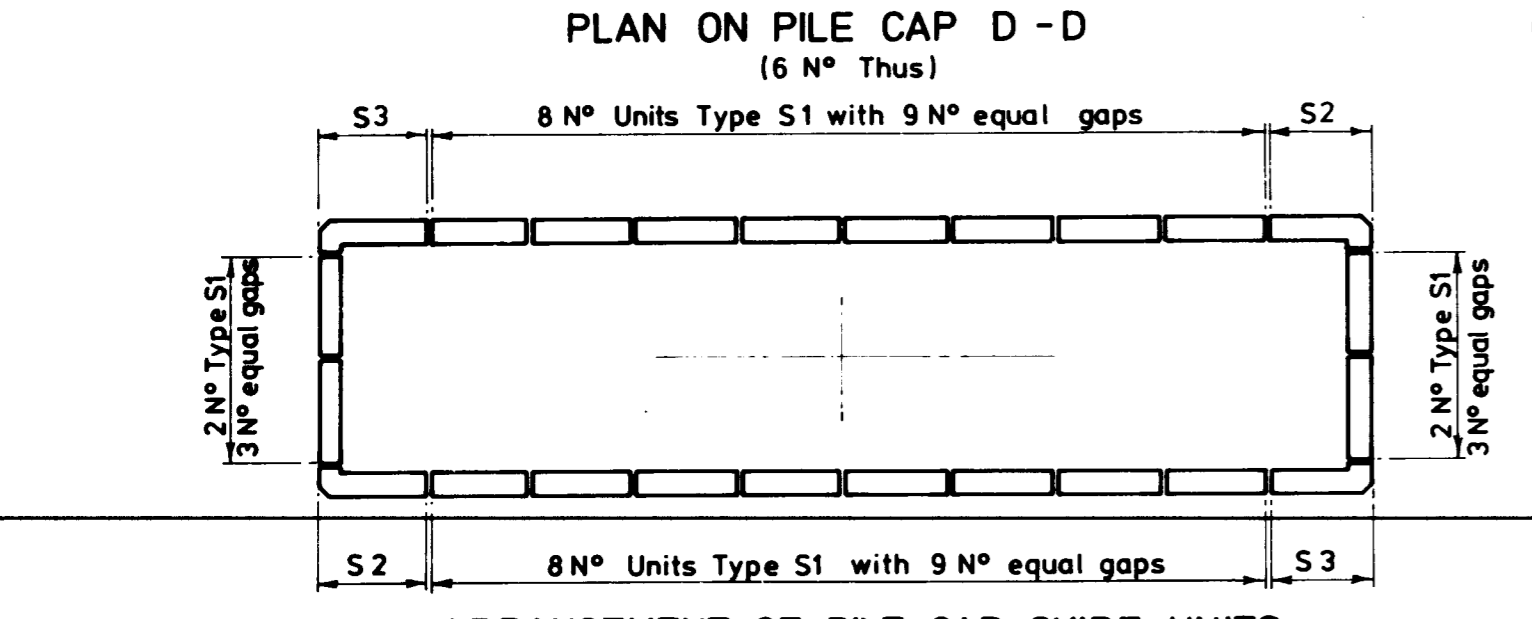
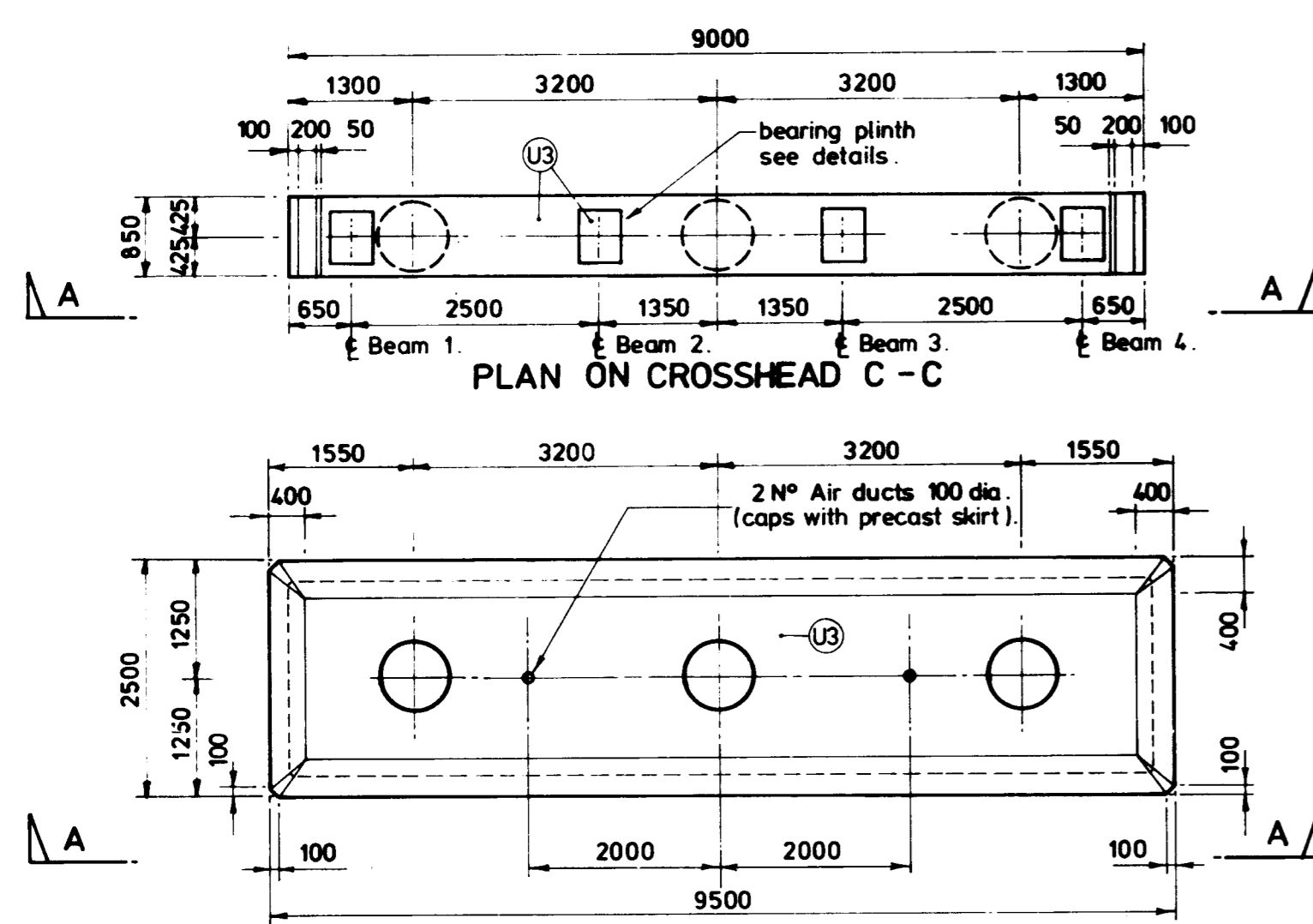
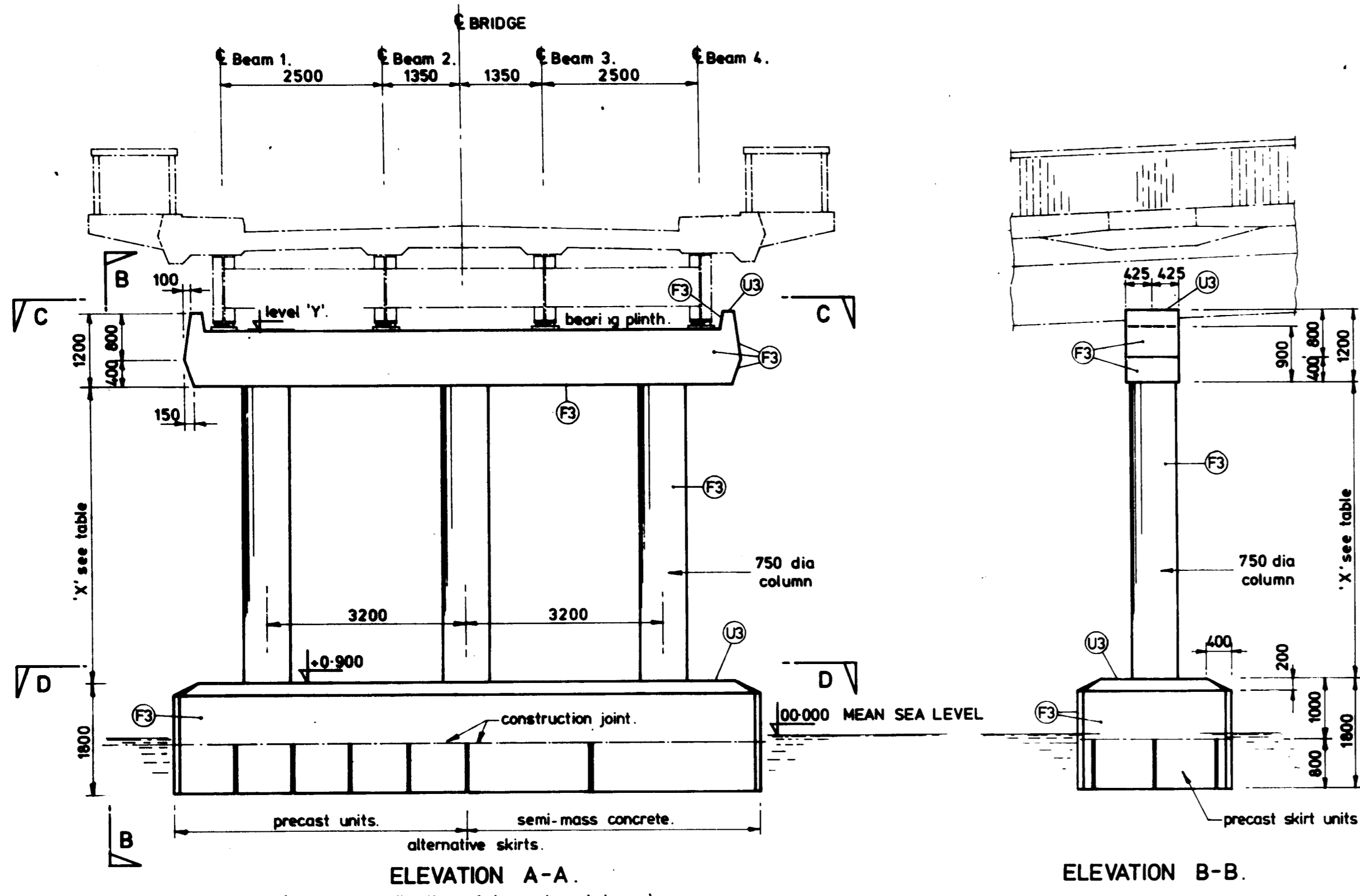

- Notes:-
- All dimensions are in millimetres
 - Levels are to Datum 000 at Mean Sea Level.
 - Surface finishes:- denoted on drawing thus (F3) formed surfaces to be F2 unless otherwise noted, unformed surfaces to be U2 unless otherwise noted.
 - Concrete classes:-
class 30/20 - mass concrete under pile cap, mass concrete crossheads.
class 37.5/20 - skirt units, pile caps, columns crossheads.
 - Cover to reinforcement: 60 mm min. unless otherwise stated.
 - Reinforcement:-
a) all reinforcement to be high yield deformed bars to BS4449 and galvanised in accordance with BS729, see Specification clause 1506.
High yield bars are shown as type Y.
b) bar mark: 20 105 Y - bar type
reference number
bar diameter.
c) laps to be 42 x bar diameter, minimum.
d) abbreviations: T = top, B = bottom, NF = near face.
 - Bending Schedule No as shown at head of each Bar Locating Table.
 - This drawing to be read in conjunction with:-
7722/3/4 - General Arrangement.
7722/3/5 - Foundation Plan.
7722/3/20 - Bearing Schedule and Details.

BAR LOCATING TABLE				
Bending Schedule No: 23142				
Bar mark	Grouping	Shape	Crs.	Total No.
PRECAST SKIRT UNITS				
SKIRT UNIT TYPE S1 (120 NO)				
16201 T	1 x 5	20	200	5
12202 T	1 x 5	32	200	5
10203 Y	1 x 4	39	175	4
10203 T	1 x 4	39	175	4
SKIRT UNIT TYPE S2 (12 NO)				
16201 T	1 x 6	20	200	6
12202 T	1 x 6	32	200	6
10204 Y	1 x 5	85	175	5
10205 T	1 x 4	36	175	4
SKIRT UNIT TYPE S3 (12 NO)				
16201 T	1 x 6	20	200	6
12202 T	1 x 6	32	200	6
10204 Y	1 x 5	85	175	5
10205 T	1 x 4	36	175	4

BAR LOCATING TABLE				
Bending Schedule No: 23143				
Bar mark	Grouping	Shape	Crs.	Total No.
MASS CONCRETE				
PILE CAP SKIRT (6 NO)				
16301 T	3 x 12	38		36
REINFORCEMENT TO SIDES AND UNDERSIDE OF SKIRT				
REIN TO BS. B283				
PIER NO 1, 2, 3, 4, 5, 6				
PIER NO 1, 2, 3, 4, 5, 6				
25 13 T	1 x 6	37		6
25 14 T	1 x 6	37		6
10 15 T	1 x 3	65		3
10 15 T	1 x 10	65		10
10 15 T	1 x 12	65		12
25 16 T	1 x 6	37		6
25 17 T	1 x 6	37		6

BAR LOCATING TABLE				
Bending Schedule No: 23141				
Bar mark	Grouping	Shape	Crs.	Total No.
PILE CAPS				
PIER NO 1, 2, 3, 4, 5, 6				
32 01 T	1 x 13	38	125	13
25 02 T	1 x 33	38	250	33
25 03 T	1 x 6	38	125	6
32 04 T	1 x 11	38	125	11
25 05 T	2 x 3	38	125	6
25 05 T	1 x 19	38	125	19
20 06 T	2 x 3	38	125	6
25 07 T	8 x 3	38	125	24
25 08 T	2 x 3	38	125	6
20 09 T	1 x 36	9961	250	36
20 10 T	2 x 17	48	125	34
20 11 T	2 x 17	48	125	34
20 12 T	2 x 3	38	125	6
20 12 T	10 x 2	38		20

BAR LOCATING TABLE				
Bending Schedule No: 23144				
Bar mark	Grouping	Shape	Crs.	Total No.
CROSSHEAD				
PIER NO 1, 2, 3, 4, 5, 6				
20 25 T	1 x 40	60		40
20 26 T	1 x 40	60		40
32 27 T	1 x 6	20		6
32 28 T	2 x 4	37		8
32 29 T	2 x 5	20		10
32 30 T	1 x 38	19		38
20 31 T	2 x 3	20		6
16 32 T	2 x 6	89		12
10 33 T	2 x 3	9905		12
20 34 T	2 x 3	38		6
10 35 T	2 x 1	60		2
10 36 T	2 x 1	60		2
10 37 T	2 x 1	20		2

Notes:-

Reinforcement in pile cap shall be fixed so that no bar is closer than 50 mm to the steel pile tubes, or closer than 25 mm to the bars from the pile encasing.

REV.	DESCRIPTION	DATE	CHECKED

GOVERNMENT OF BERMUDA

NEW WATFORD BRIDGE

DETAILS OF PIERS.

PUBLIC WORKS DEPT. HAMILTON 5 BERMUDA

G. MAUNSELL & PARTNERS CONSULTING ENGINEERS LONDON S.E. 20.

SCALE: 1:10, 1:20, 1:50, 1:100

DATE: MAY 1979

DRAWN BY: N.A.R.

DRG. NO. 7722/3/14

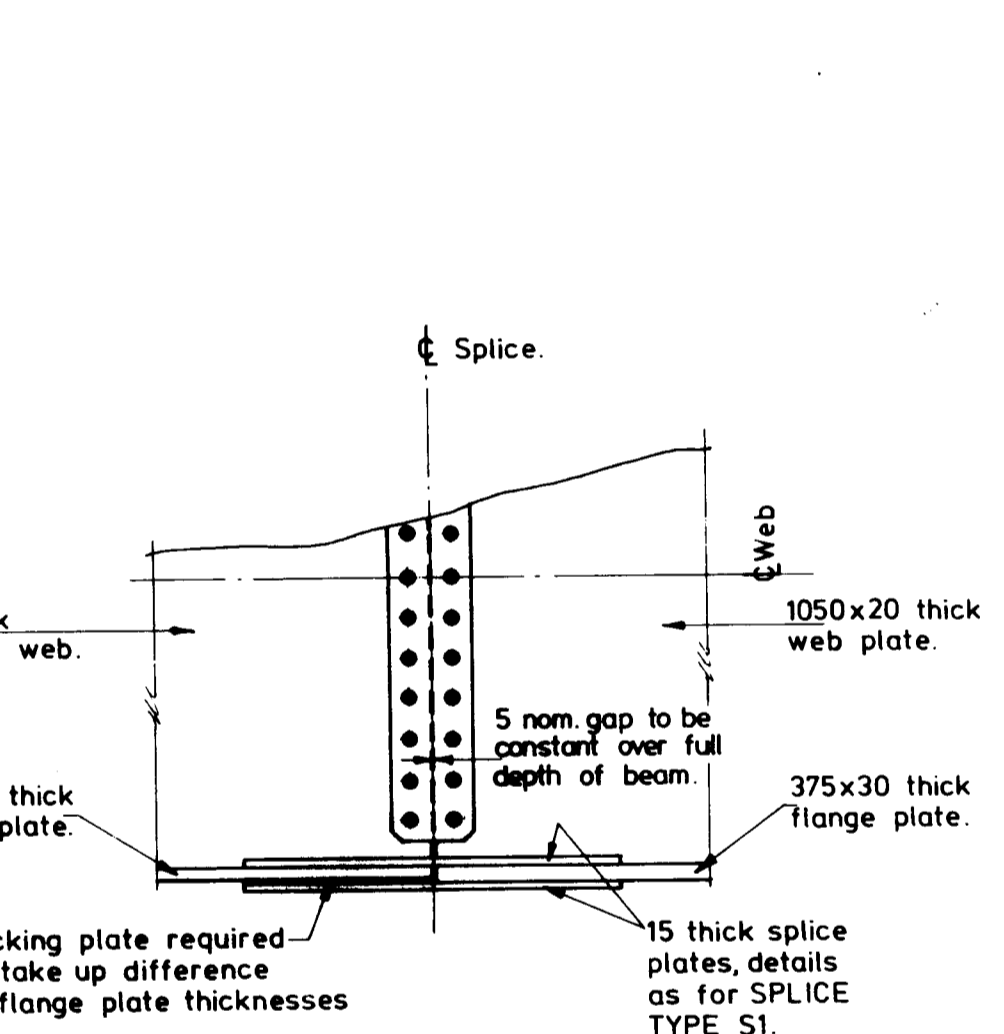
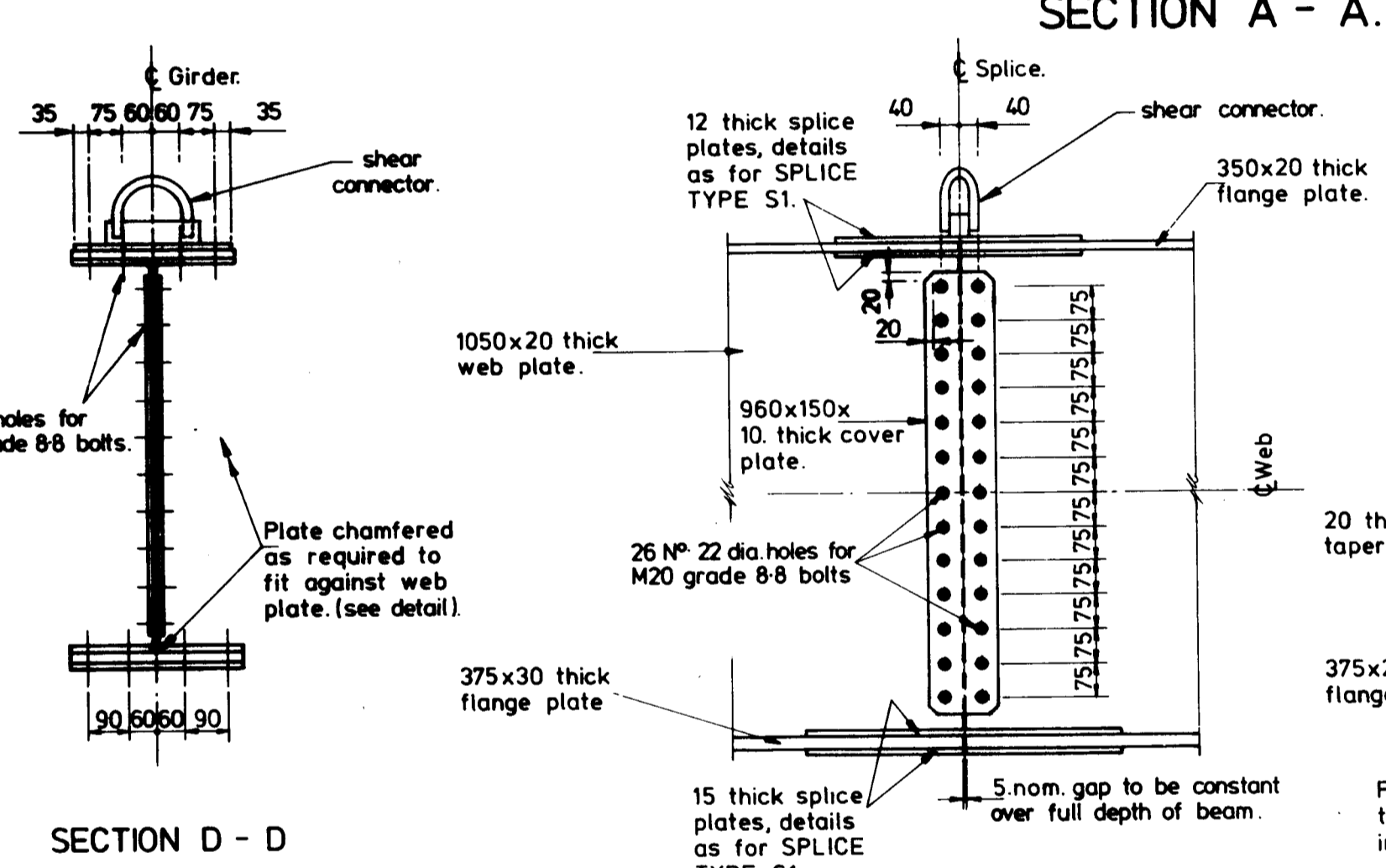
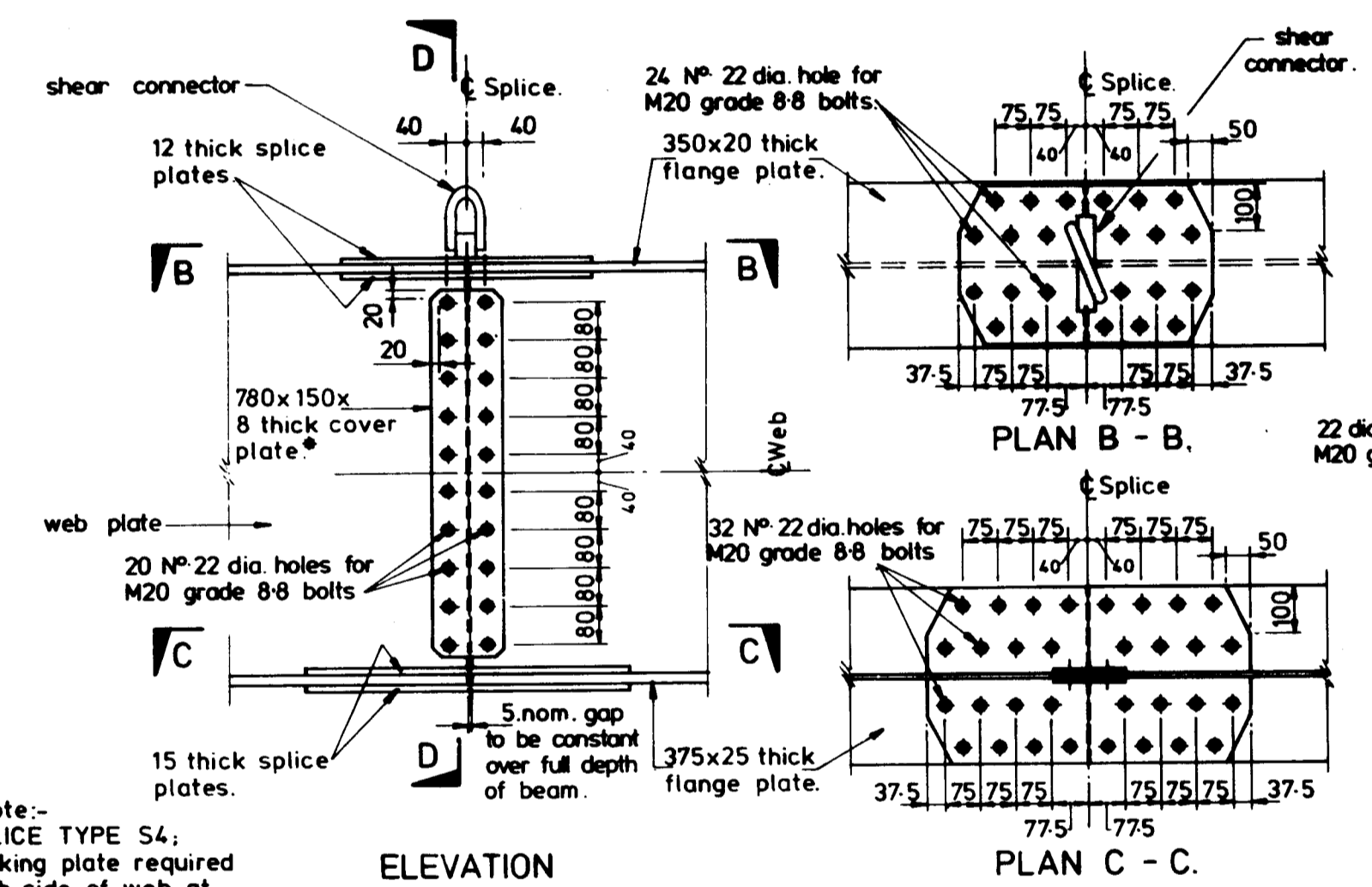
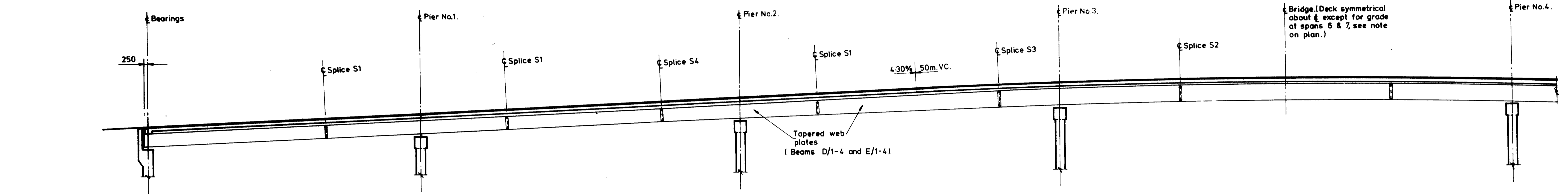
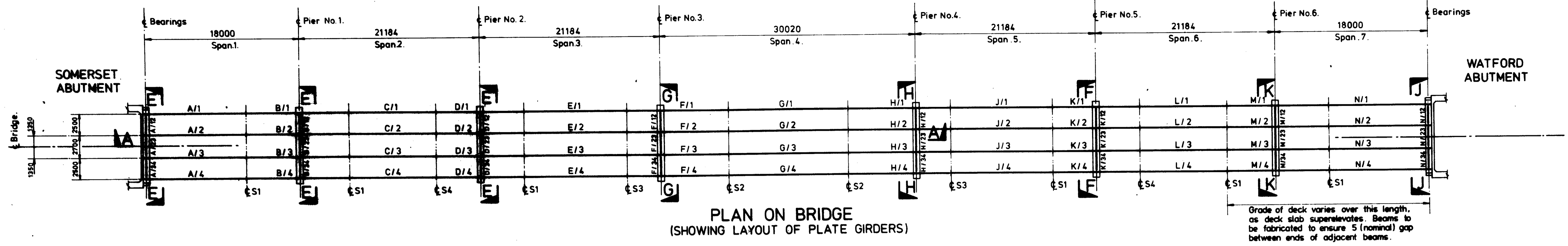

- Notes:-
- All dimensions are in millimetres.
 - Levels are given to datum 0.000 at Mean Sea Level.
 - All weldable structural steelwork shall be to BS 4360:1972 Grade 50C except the top flange and top flange splice plates to the plate girders which shall be Grade 43C.
 - Weld sizes:
Top flange to web :- 6mm full penetration fillet weld both sides of web.
Bottom flange to web :- 8mm full penetration fillet weld both sides of web.
 - All rolled sections shall be to BS 4360:1972 Grade 50C and conform to BS 4:1972.
 - Length of beam shown is the maximum overall dimension.
 - End face of beams at abutments (beams A and N) to be vertical after final alignment and leveling.
 - Web stiffener plates to be vertical (ie. normal to underside of bearing plate).
 - Bolting Details:
a) All connections to be made using Grade 8.8 ISO Metric Precision Hexagon Bolts, Nuts and Washers in accordance with BS 3692:1967.
b) Bolts shall be tightened to a minimum torque of 10 kgm.
 - Shear Connectors:
a) Bars to be to BS 4360:1972 Grade 50C.
b) Hoops to be formed from round bar to BS 4360:1972 Grade 55C.
 - Protective Treatment:
a) All steelwork to be hot dipped galvanised and shop painted. Upper surface of top flange of plate girders including shear connectors and top splice cover plate to remain unpainted except for outer edge strip 20mm wide around perimeter. (see detail).
b) All nuts, bolts and washers to be sherardized.
c) All splice plates to have edges of faying surfaces liberally coated with finishing coat paint for a width of 25mm immediately prior to bolting. (see detail).

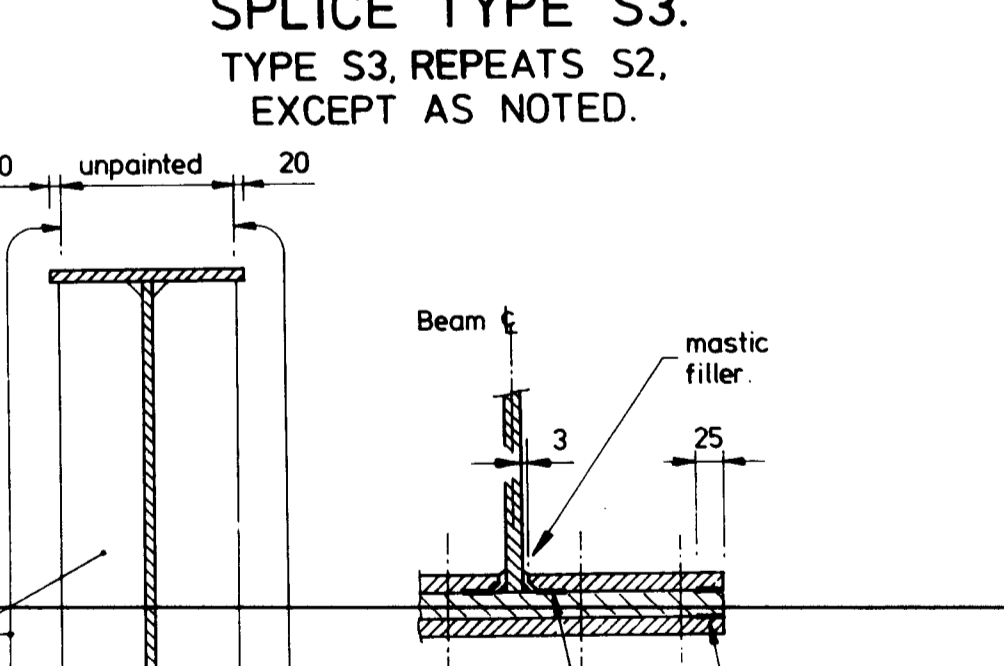
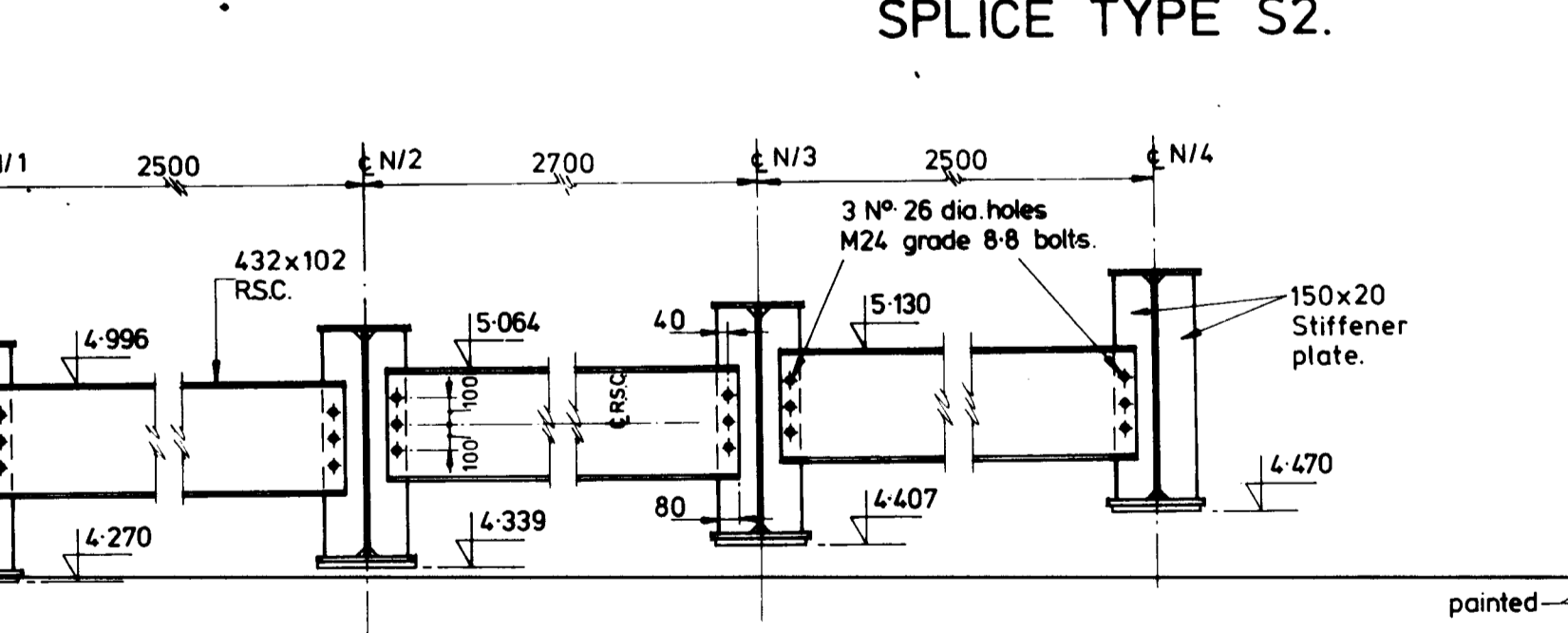
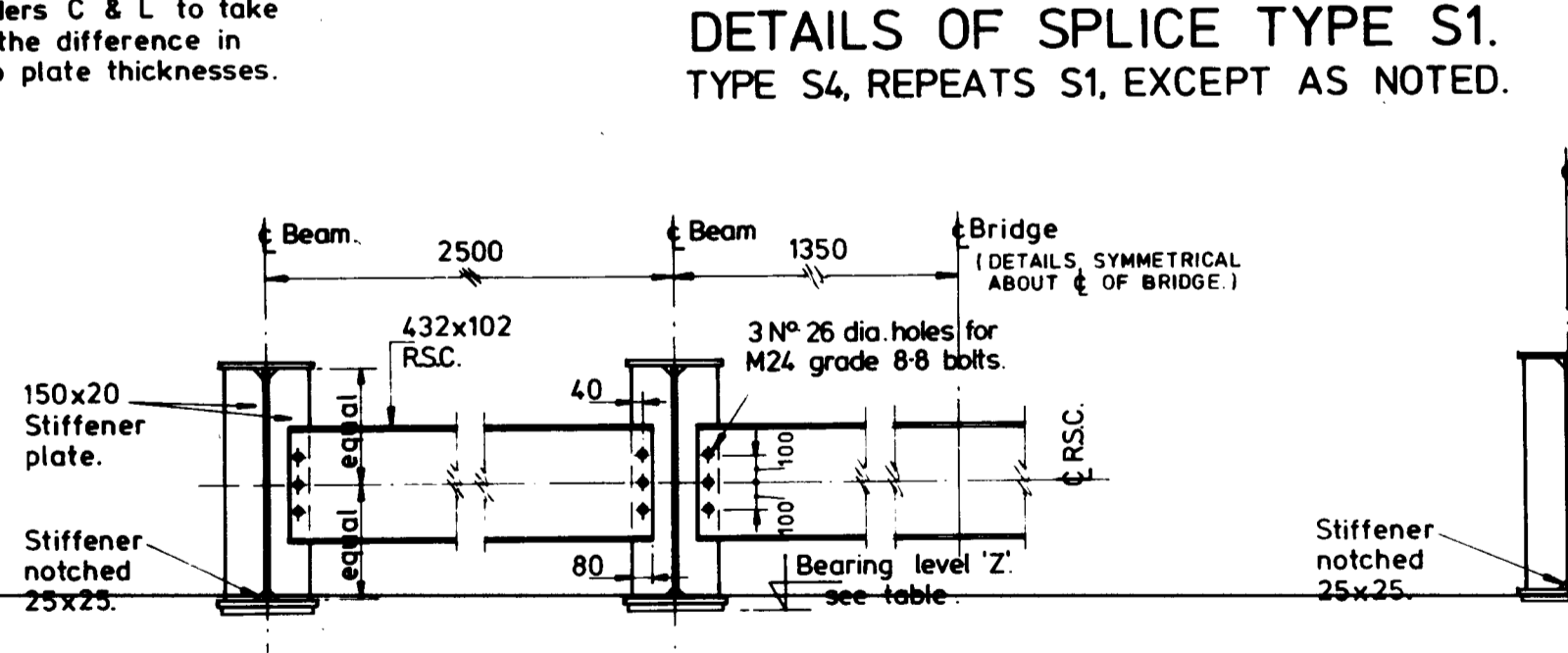

PAINTING.
PROTECTIVE TREATMENT.
(see Note 11).

Location	Bearing Level 'Z'
Somerset Abut.	4.342
Pier 1	5.116
Pier 2	5.972
Pier 3	6.647
Pier 4	6.647
Pier 5	5.972
Pier 6	see Section K-K
Watford Abut	see Section J-J

TABLE OF BEARING LEVELS.

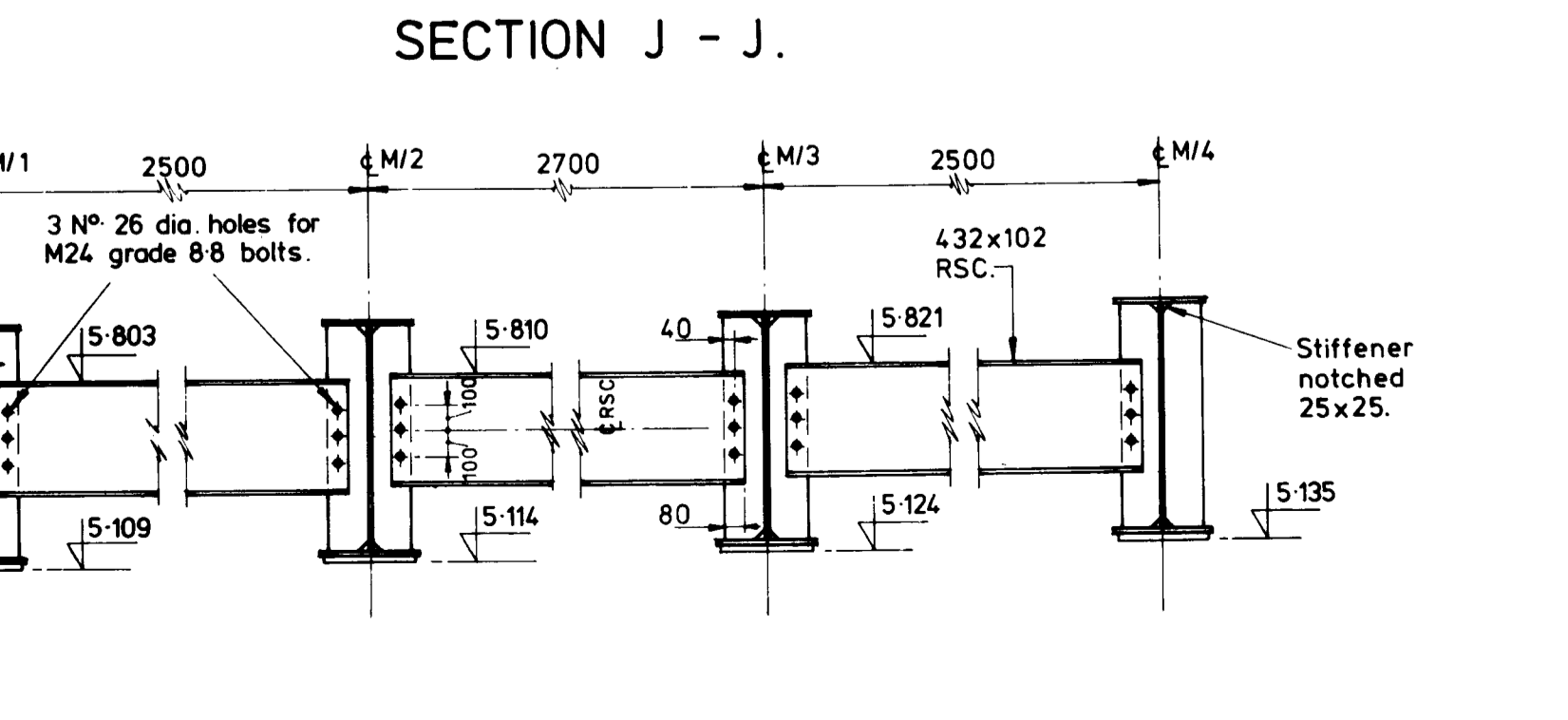
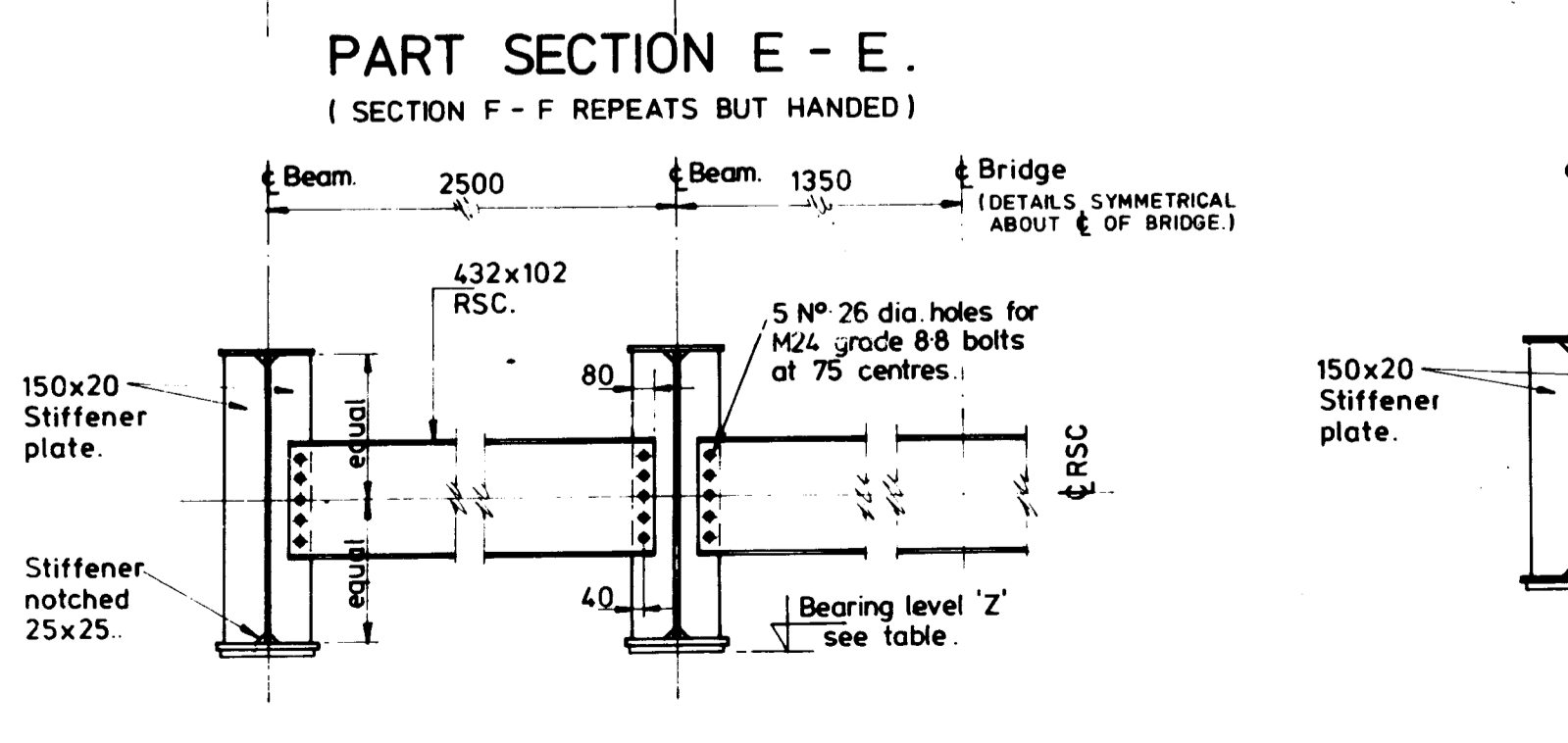

REV.	DESCRIPTION	DATE	CHECKED
GOVERNMENT OF BERMUDA			
NEW WATFORD BRIDGE			
DECK STEELWORK			
SHEET 1.			
PUBLIC WORKS DEPT. HAMILTON 5 BERMUDA		G. MALUNSELL & PARTNERS CONSULTING ENGINEERS LONDON S.E. 20.	
SCALE: 1:200, 1:100, 1:10, 1:20.		DRG. NO.	
DATE: MAY 1979.	DRAWN BY: JD.	7722/3/15.	

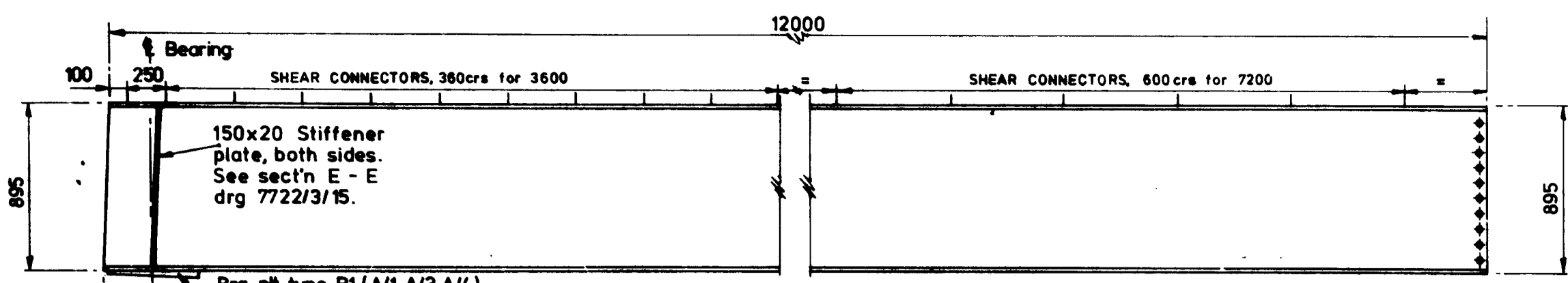

ELEVATION-GIRDERS A/1, A/2, A/3 & A/4.
GIRDERS N/1 N/2 N/3 & N/4 REPEAT BUT ARE HANDED.

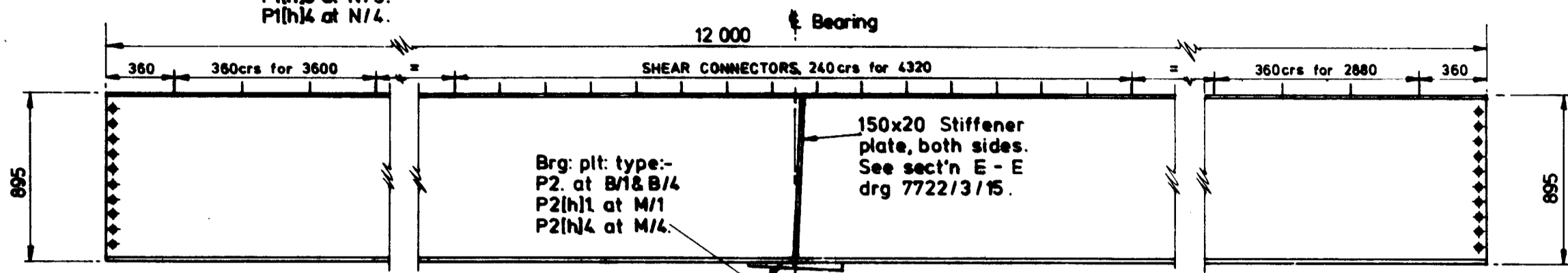

ELEVATION-GIRDERS B/1 & B/4
GIRDERS M/1 & M/4 REPEAT BUT ARE HANDED.

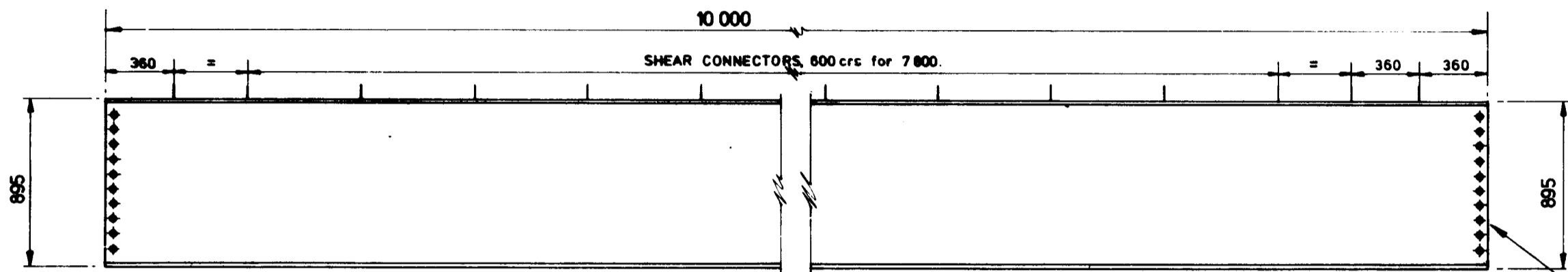

ELEVATION-GIRDERS C/1, C/2, C/3 & C/4.
GIRDERS L/1 L/2 L/3 & L/4 REPEAT BUT ARE HANDED.

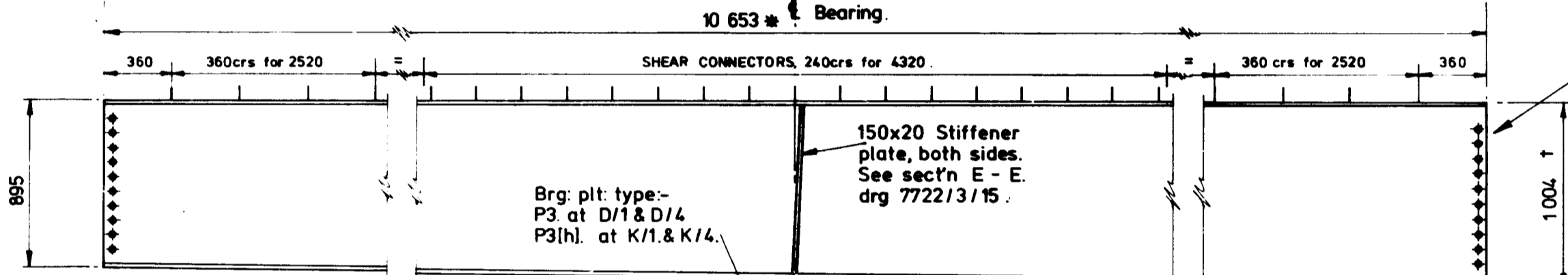

ELEVATION-GIRDERS D/1 & D/4.
GIRDERS K/1 & K/4 REPEAT BUT ARE HANDED.

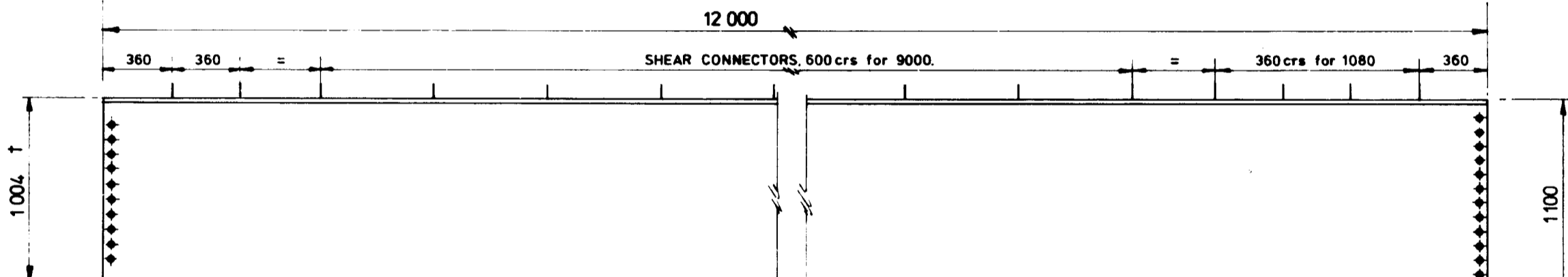

ELEVATION-GIRDERS E/1, E/2, E/3 & E/4.
GIRDERS J/1, J/2, J/3 & J/4 REPEAT BUT ARE HANDED.

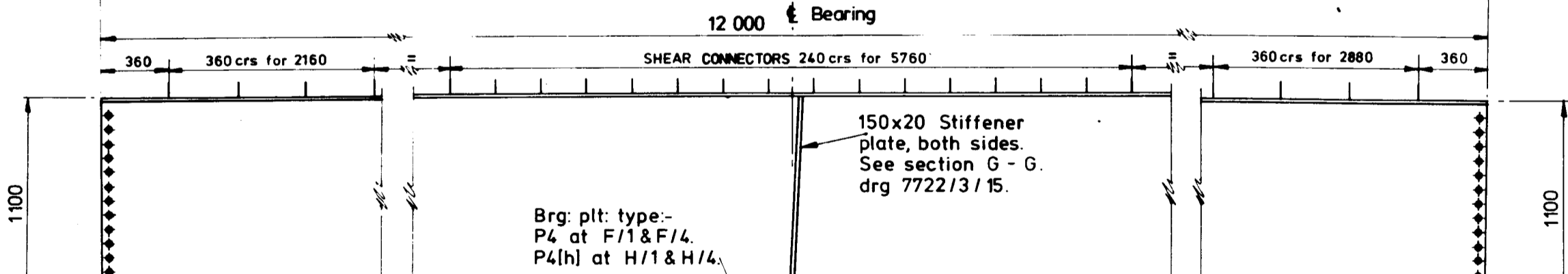

ELEVATION-GIRDERS F/1 & F/4.
GIRDERS H/1 & H/4 REPEAT BUT ARE HANDED.

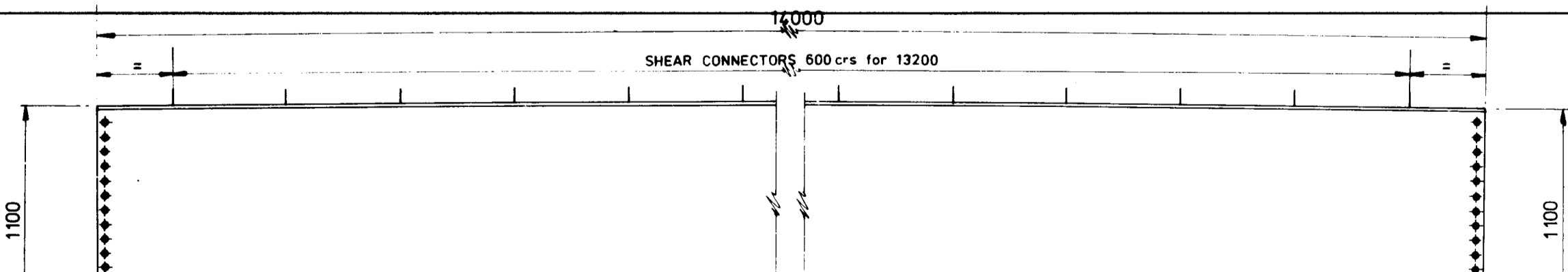

ELEVATION-GIRDERS G/1, G/2, G/3 & G/4.

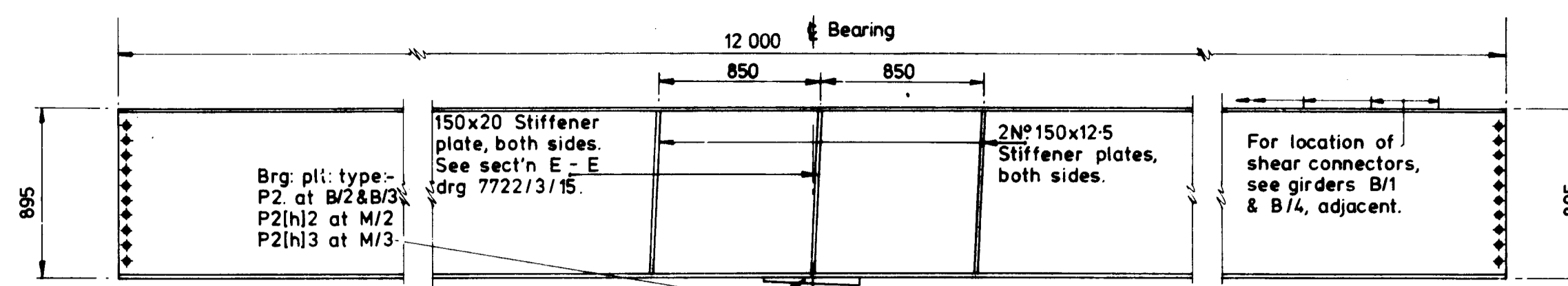

ELEVATION-GIRDERS B/2 & B/3.
GIRDERS M/2 & M/3 REPEAT BUT ARE HANDED.

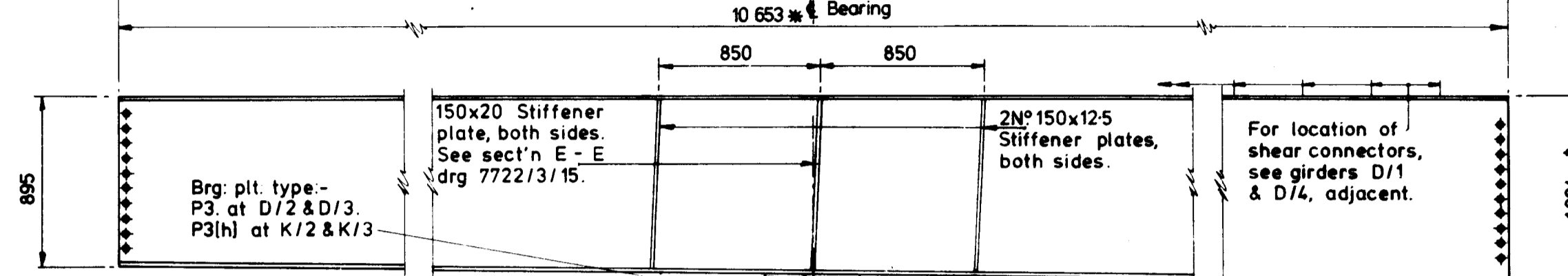

ELEVATION-GIRDERS D/2 & D/3.
GIRDERS K/2 & K/3 REPEAT BUT ARE HANDED.

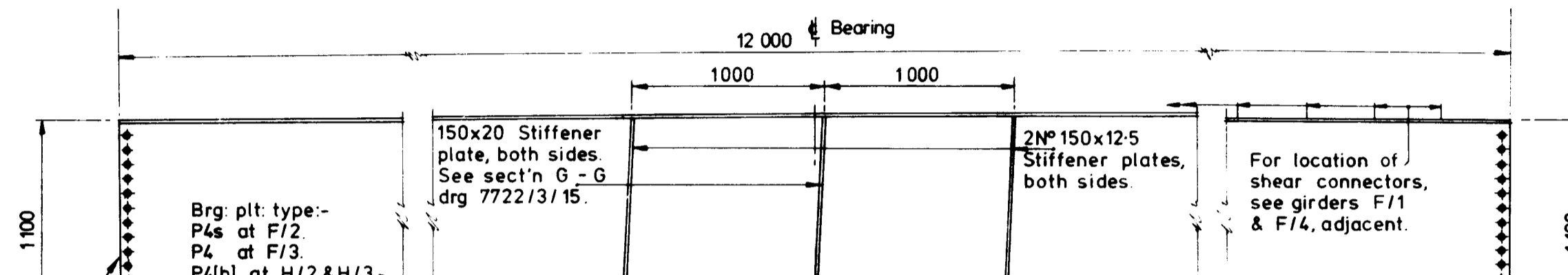

ELEVATION-GIRDERS F/2 & F/3.
GIRDERS H/2 & H/3 REPEAT BUT ARE HANDED.

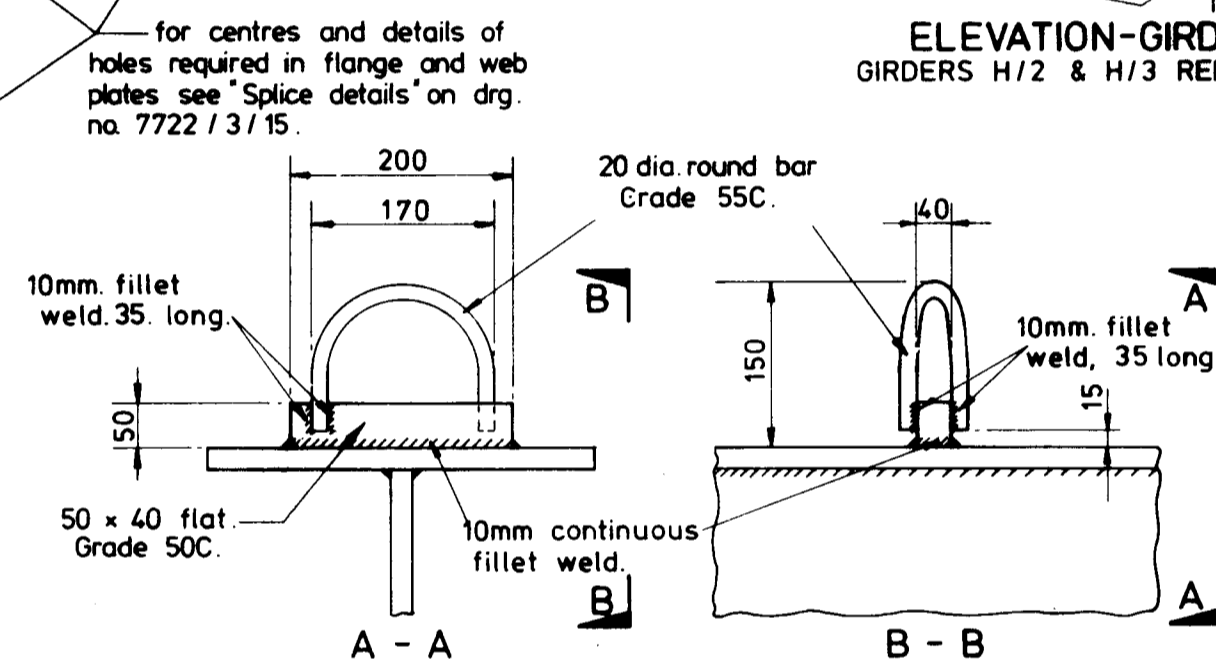

TYPICAL DETAIL OF SHEAR CONNECTOR

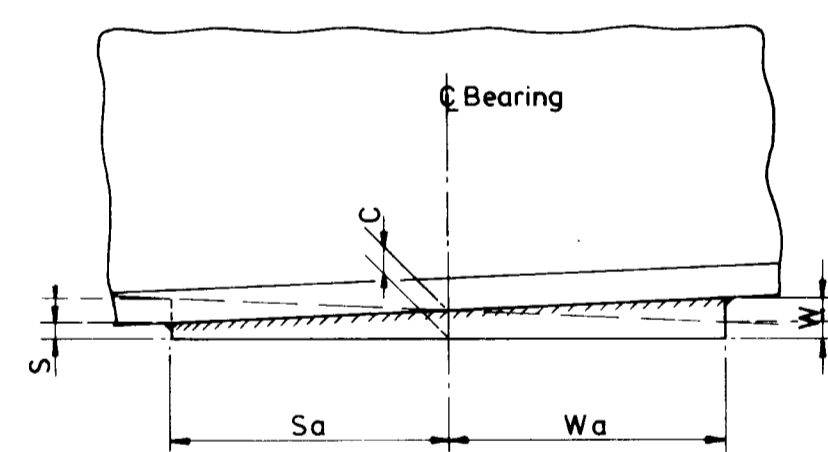

ELEVATION.

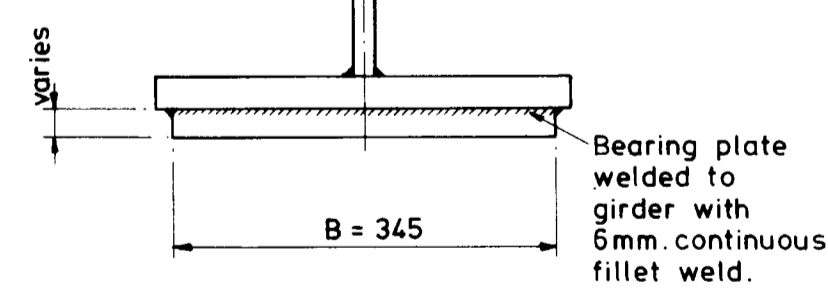

SECTION - BEARING PLATE 345 WIDE.

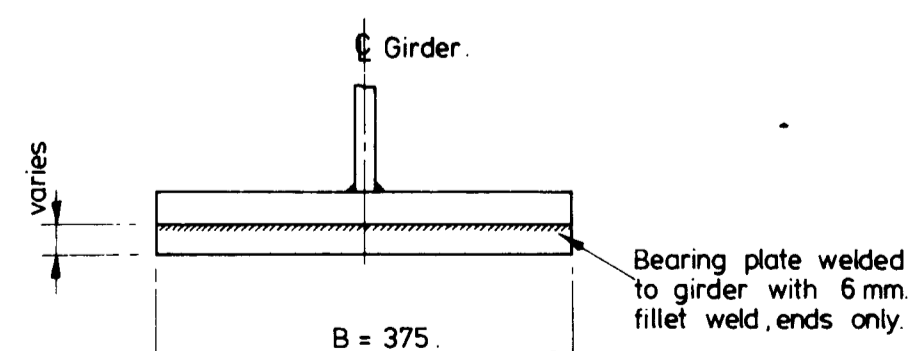

SECTION - BEARING PLATE 375 WIDE.
PLATES P1a & P1h2 ONLY.

DETAILS OF BEARING PLATES.

Brg plate type	DIMENSIONS						Total Nos off	Restrained
	Sa	Wa	B	S	W	C		
P1	225	225	345	15	35	25	3	
P1a	225	225	375	15	35	25	1	Restrained
P2	225	225	345	15	35	25	4	
P3	225	225	345	18	33	25	4	
P4	225	225	345	20	31	25	3	
P4s	225	225	345	20	31	25	1	Fixed
P1(h)1	225	225	345	36	14	25	1	
P1(h)2	225	225	375	35	16	25	1	Restrained
P1(h)3	225	225	345	34	16	25	1	
P1(h)4	225	225	345	33	17	25	1	
P2(h)1	225	225	345	35	15	25	1	
P2(h)2	225	225	345	35	15	25	1	
P2(h)3	225	225	345	35	16	25	1	
P2(h)4	225	225	345	34	16	25	1	
P3(h)	225	225	345	33	18	25	4	
P4(h)	225	225	345	31	20	25	4	

Note:- for details of Bearing Plates see drg. no. 7722/3/20 - Bearing Schedule and Details.

BEAM REF.	LENGTH	PLATE SIZES			BEARING PLATE TYPE
		web	flg.	top flg.	
A/1					P1
A/2	12000	850x15	375x25	350x20	P1a
A/3					P1
A/4					P1
B/1					P2
B/2	12000	850x15	375x25	350x20	P2
B/3					P2
B/4					P2
C/1					
C/2	10000	850x15	375x25	350x20	
C/3					
C/4					
D/1					P3
D/2	10653	850 to 959	375x25	350x20	P3
D/3	*	20			P3
D/4					P3
E/1					
E/2	12000	959 to 1050	375x25	350x20	
E/3		20			
E/4					
F/1					P4
F/2	12000	1050x20	375x30	350x20	P4s
F/3					P4
F/4					P4
G/1					
G/2	14000	1050x20	375x30	350x20	
G/3					
G/4					
H/1					P4(h)
H/2	12000	1050x20	375x30	350x20	P4(h)
H/3					P4(h)
H/4					P4(h)
J/1					
J/2	12000	959 to 1050	375x25	350x20	
J/3		20			
J/4					
K/1					P3(h)
K/2	10653	850 to 959	375x25	350x20	P3(h)
K/3	*	20			P3(h)
K/4					P3(h)
L/1					
L/2	10000	850x15	375x25	350x20	
L/3					
L/4					
M/1					P2(h)1
M/2	12000	850x15	375x25	350x20	P2(h)2
M/3					P2(h)3
M/4					P2(h)4
N/1					P1(h)1
N/2	12000	850x15	375x25	350x20	P1(h)2
N/3					P1(h)3
N/4					P1(h)4

Note:- † approx. dimension adjusted to achieve the same grade to bottom flanges of adjacent tapered beams.
* approx. dimension adjusted to achieve the correct finished profile.

TRANSVERSE BEAMS		
REFERENCE	SIZE	LENGTH
A/12, A/34, B/12, B/34, M/12, M/34, N/12, N/34	432x102 RSC	2345
A/23, B/23, M/23, N/23	432x102 RSC	2545
D/12, D/34, K/12, K/34, F/12, F/34, H/12, H/34	432x102 RSC	2340
D/23, K/23, F/23, H/23	432x102 RSC	2540

Note:- this drawing to be read in conjunction with drawing no. 7722/3/15 - Deck Steelwork. Sheet 1.

REV.	DESCRIPTION	DATE	CHECKED
GOVERNMENT OF BERMUDA			
NEW WATFORD BRIDGE			
DECK STEELWORK			
SHEET 2.			
PUBLIC WORKS DEPT. HAMILTON 5 BERMUDA		G. MALINSELL & PARTNERS CONSULTING ENGINEERS LONDON S.E. 20.	
SCALE: 1:20, 1:5		DRG. NO.	
DATE: MAY 1979		DRAWN BY: JD.	
7722/3/16.			

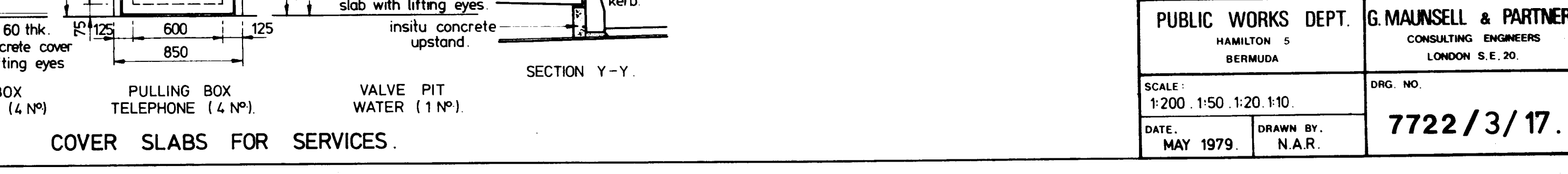
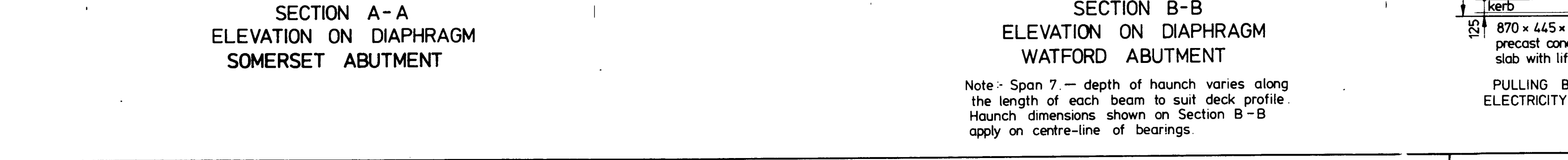
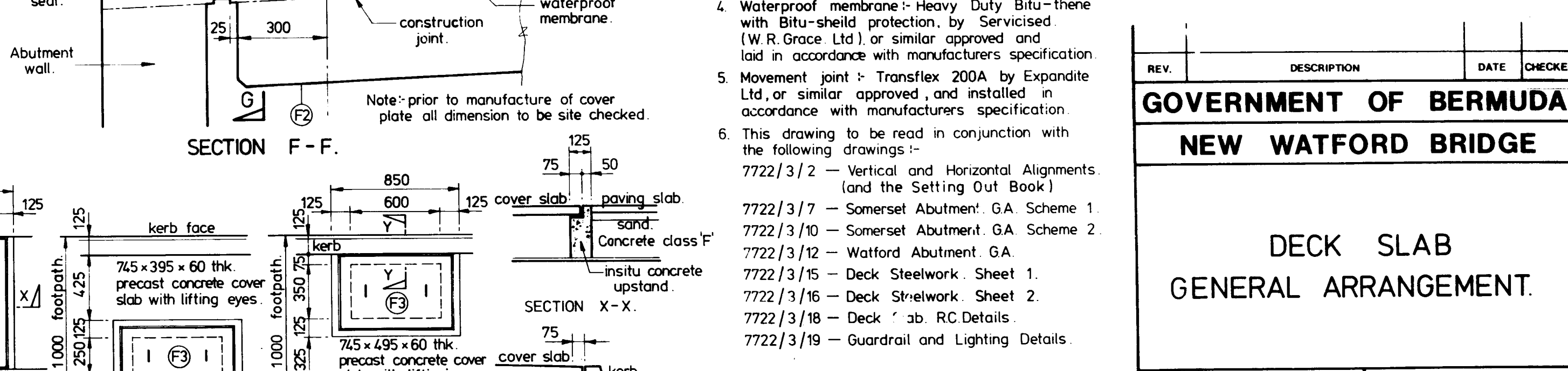
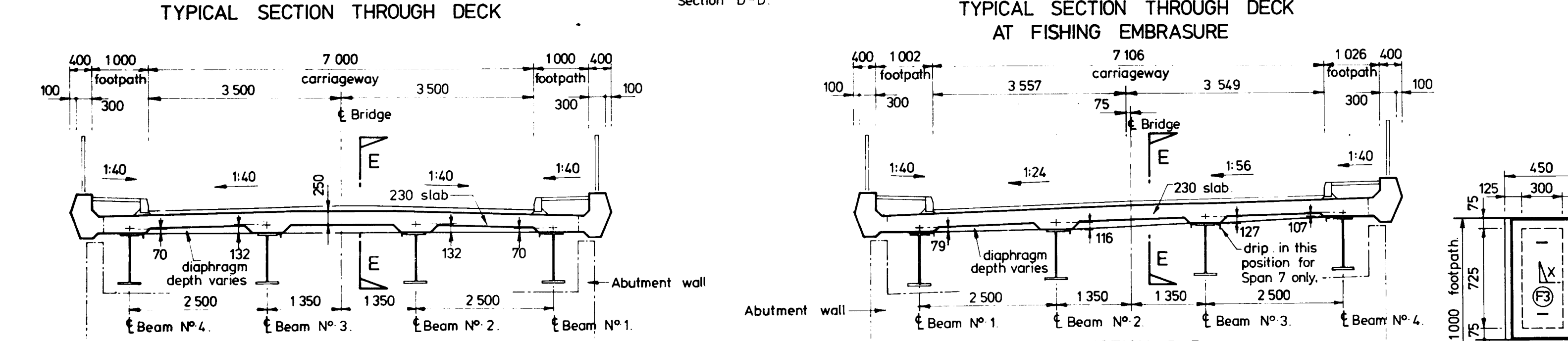
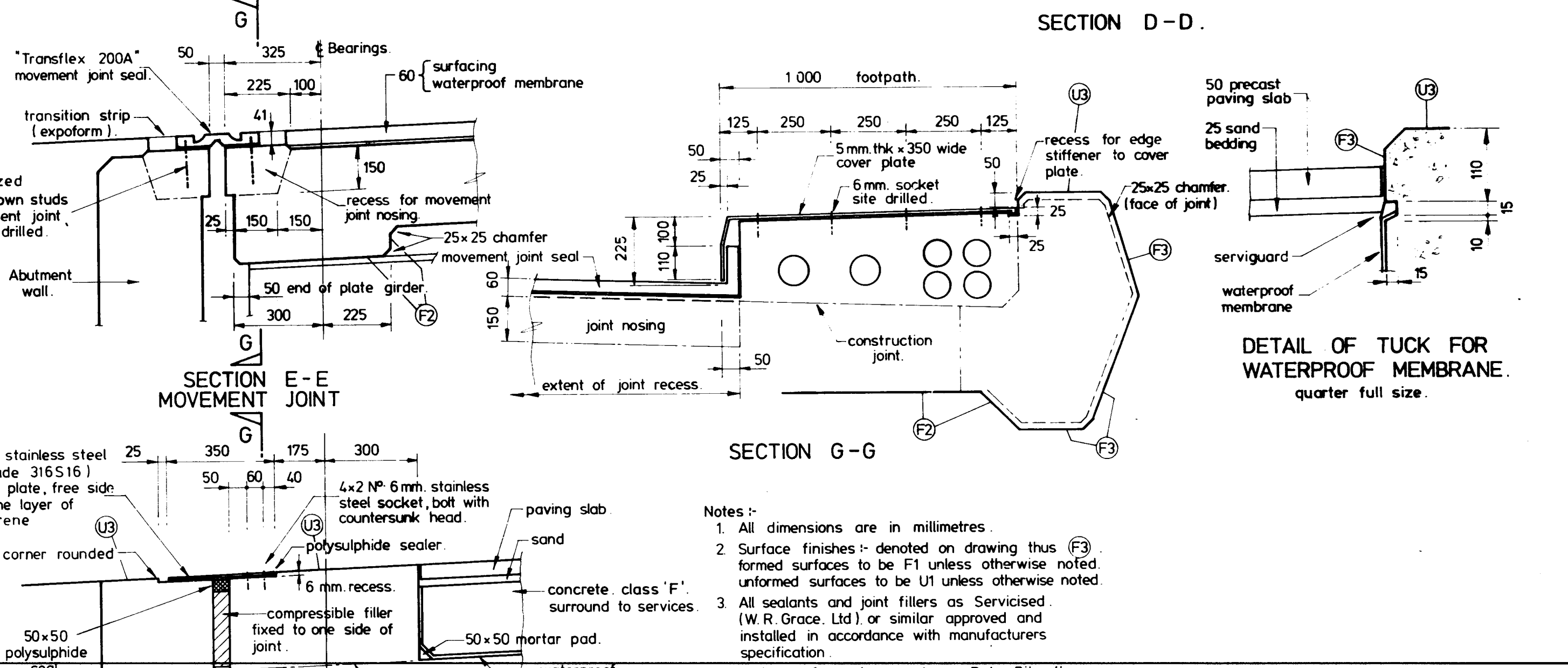
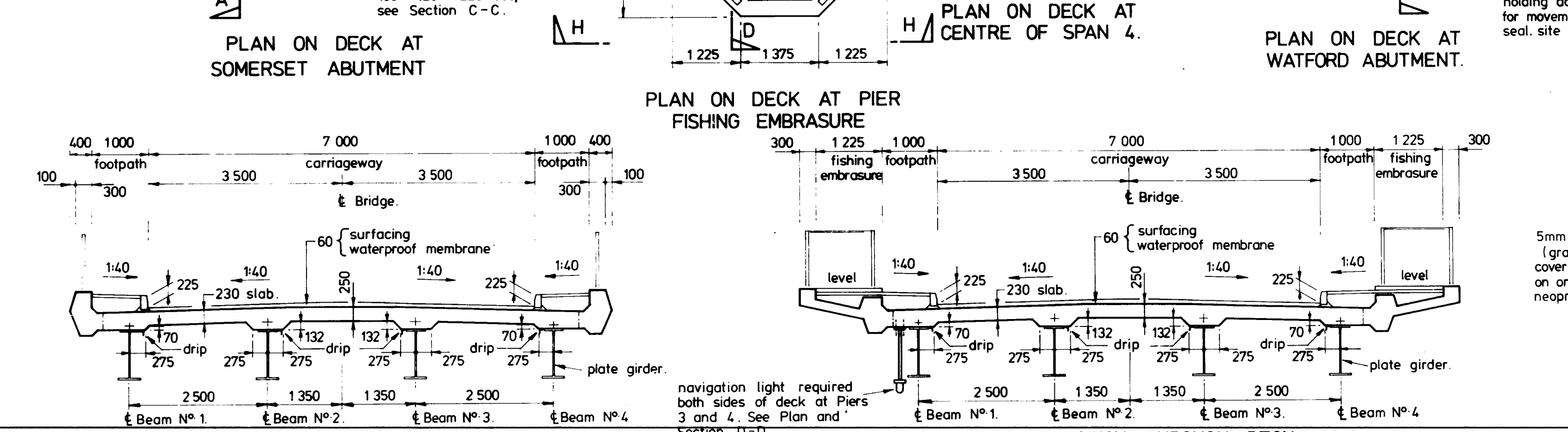
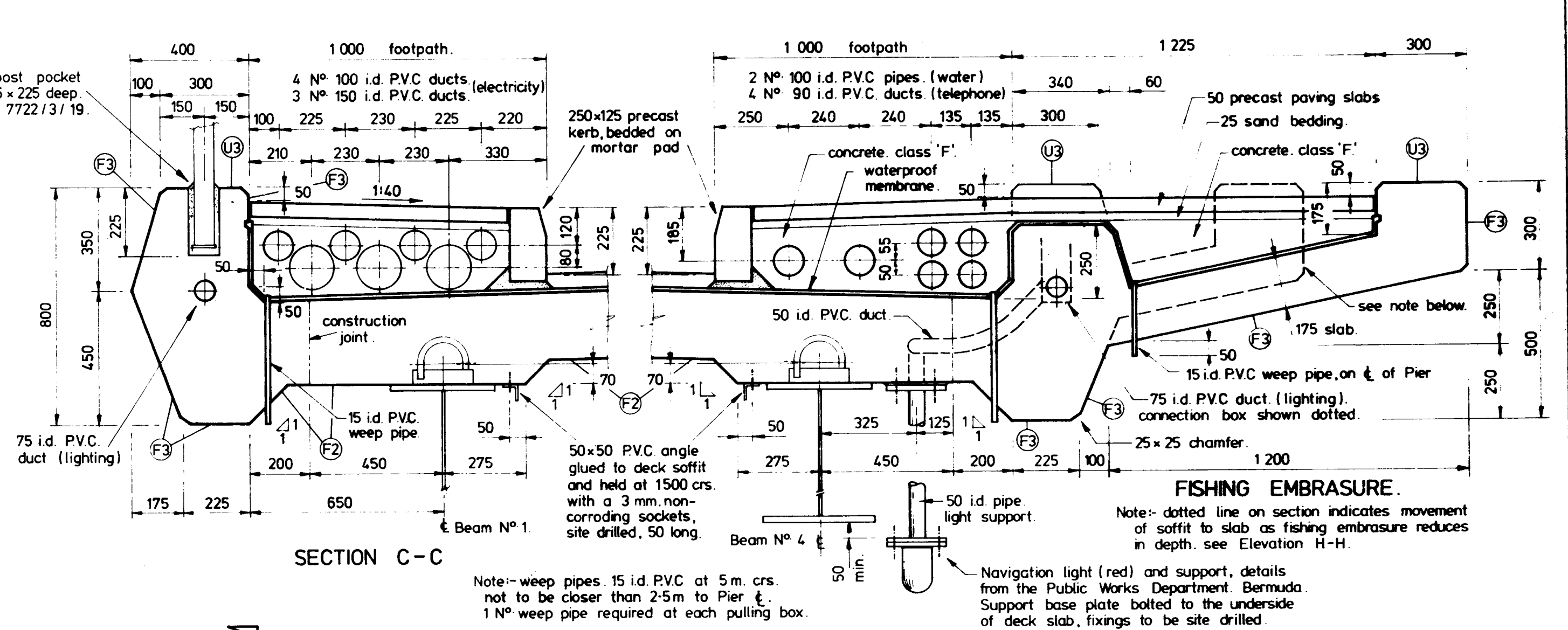
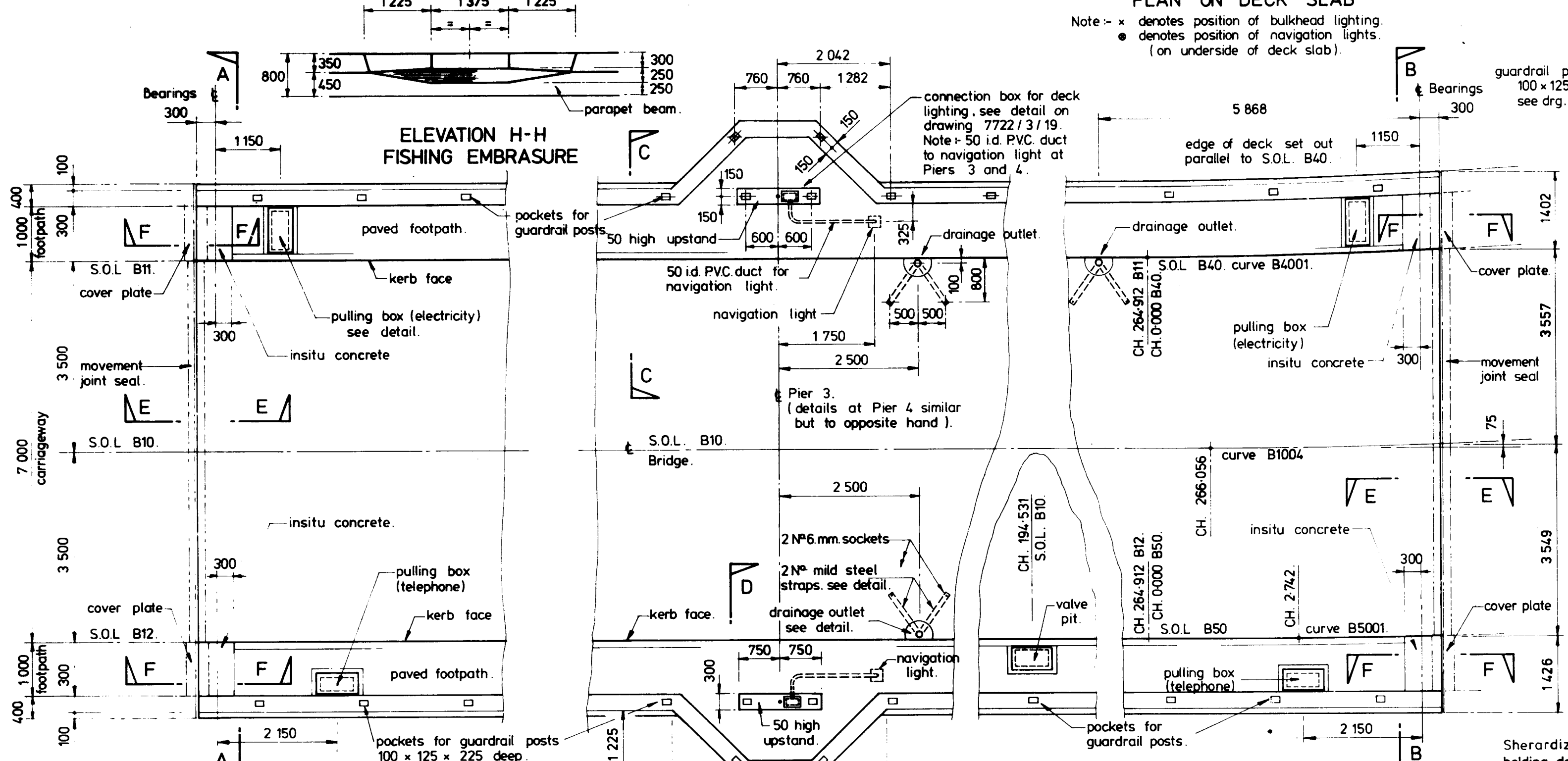
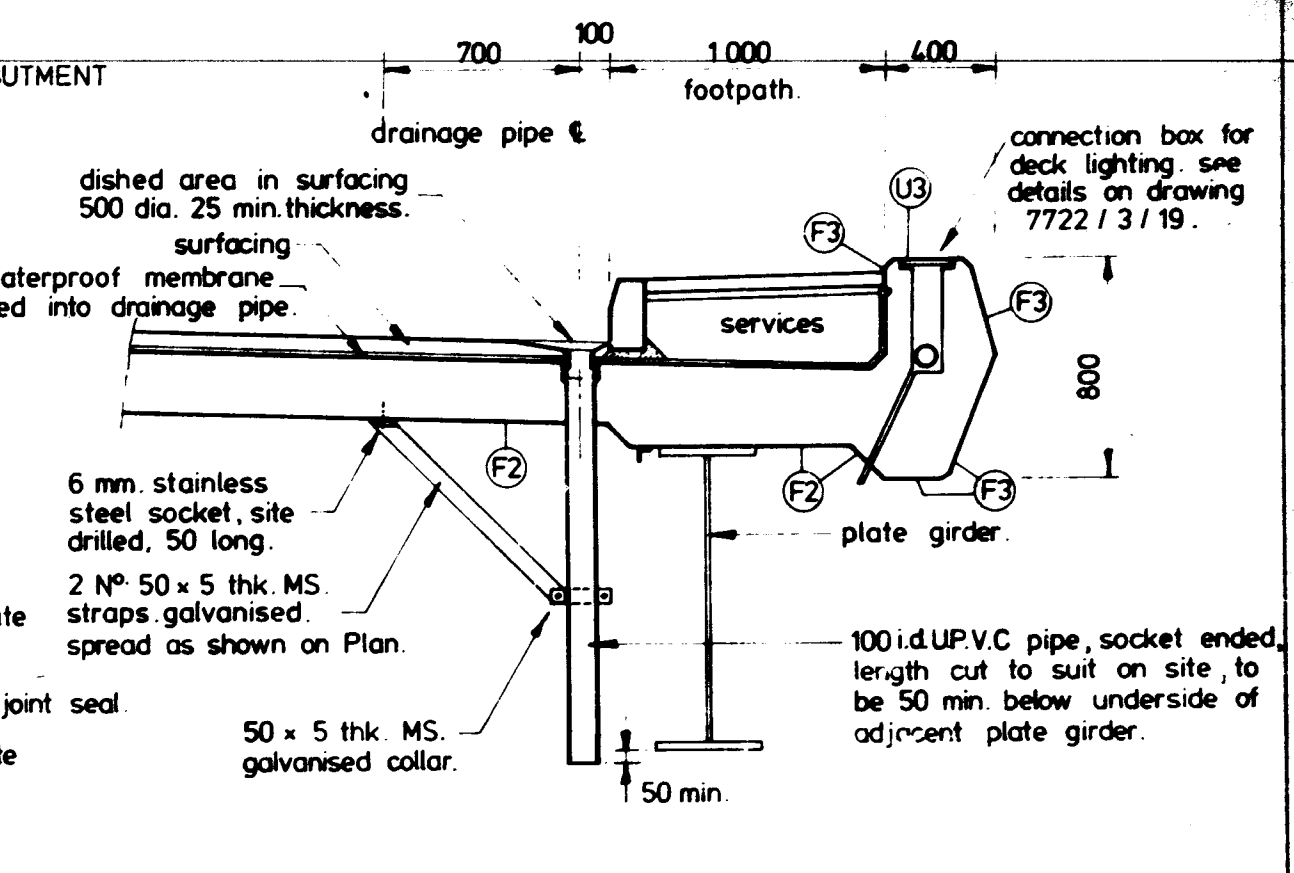
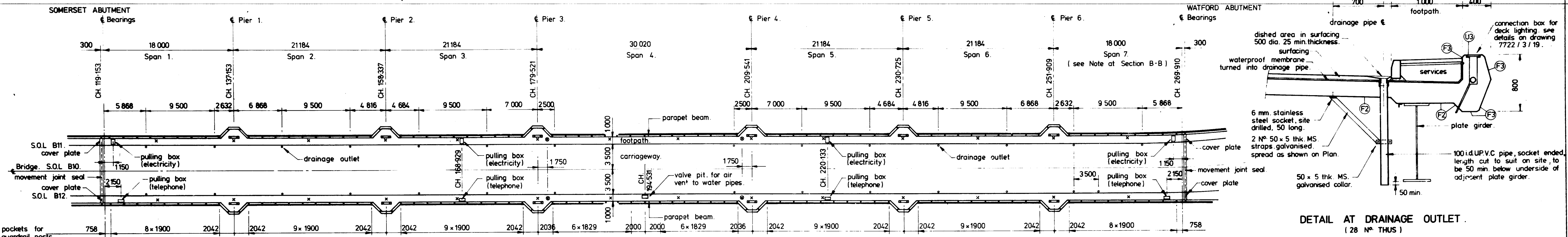

- Notes:**
- All dimensions are in millimetres.
 - Surface finishes: denoted on drawing thus (F3) formed surfaces to be F1 unless otherwise noted, unformed surfaces to be U1 unless otherwise noted.
 - All sealants and joint fillers as Servisiced (W.R. Grace Ltd.) or similar approved and installed in accordance with manufacturers specification.
 - Waterproof membrane: Heavy Duty Bitu-there with Bitu-shield protection, by Servisiced (W.R. Grace Ltd.) or similar approved and laid in accordance with manufacturers specification.
 - Movement joint: Transflex 200A by Expandite Ltd. or similar approved and installed in accordance with manufacturers specification.
 - This drawing to be read in conjunction with the following drawings:-
 7722/3/2 - Vertical and Horizontal Alignments (and the Setting Out Book)
 7722/3/7 - Somerset Abutment GA Scheme 1
 7722/3/10 - Somerset Abutment GA Scheme 2
 7722/3/12 - Watford Abutment GA
 7722/3/15 - Deck Steelwork Sheet 1
 7722/3/16 - Deck Steelwork Sheet 2
 7722/3/18 - Deck 'ab RC Details
 7722/3/19 - Guardrail and Lighting Details.

REV.	DESCRIPTION	DATE	CHECKED
GOVERNMENT OF BERMUDA			
NEW WATFORD BRIDGE			
DECK SLAB GENERAL ARRANGEMENT.			
PUBLIC WORKS DEPT. HAMILTON 5 BERMUDA		G. MAUNSELL & PARTNERS CONSULTING ENGINEERS LONDON S.E. 20.	
SCALE: 1:200, 1:50, 1:20, 1:10		DRG. NO. 7722/3/17	
DATE: MAY 1979		DRAWN BY: N.A.R.	

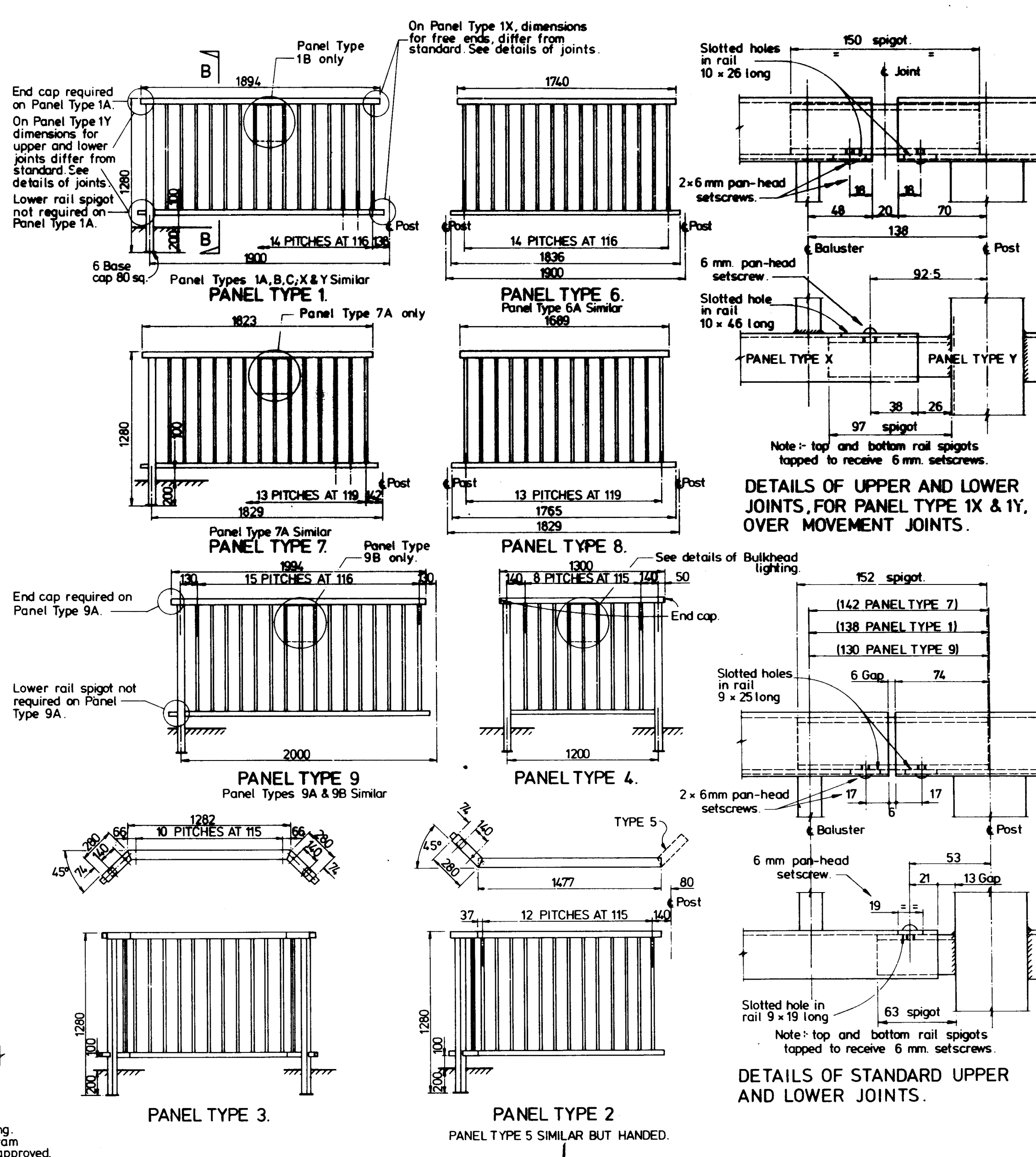
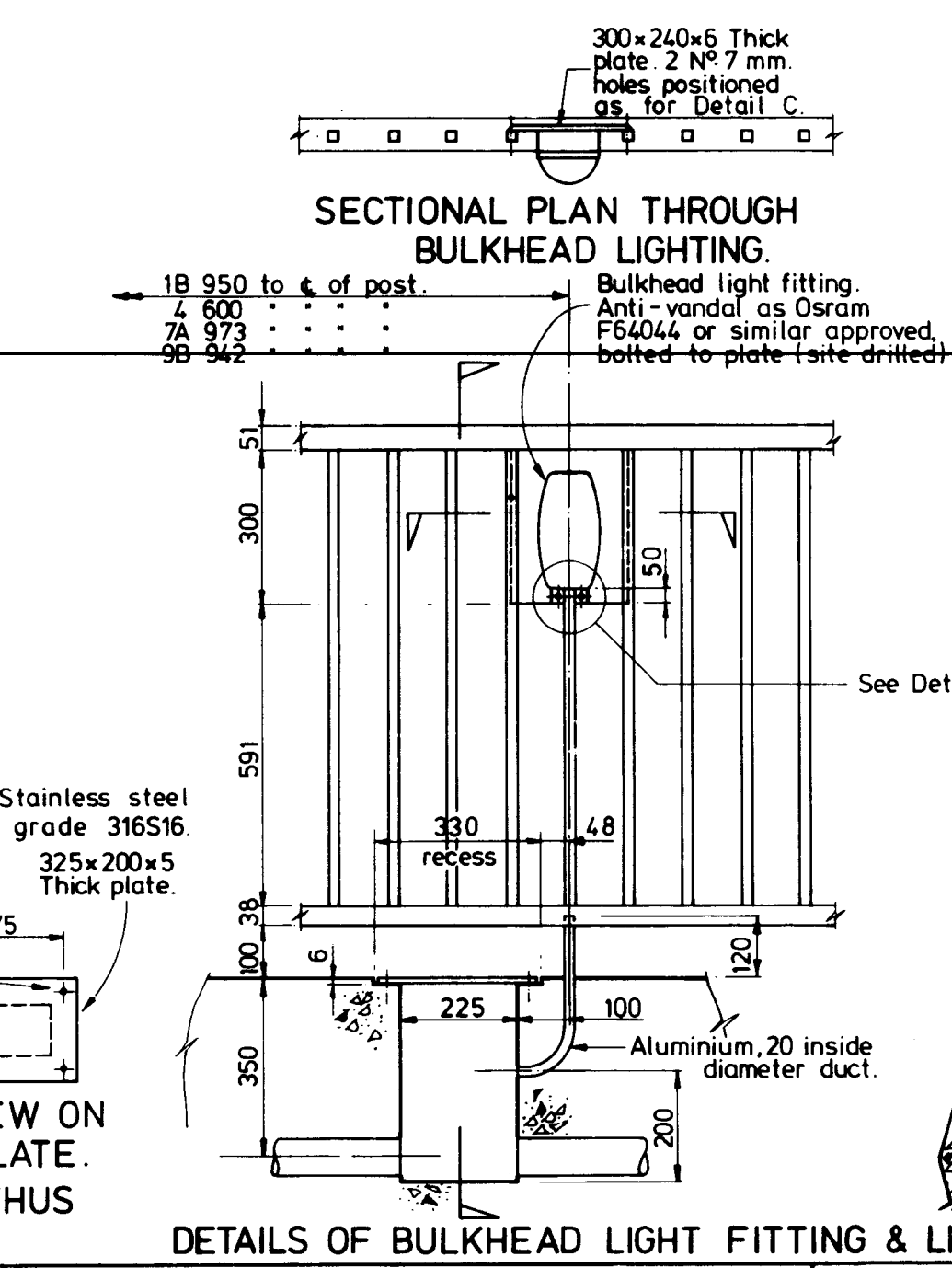
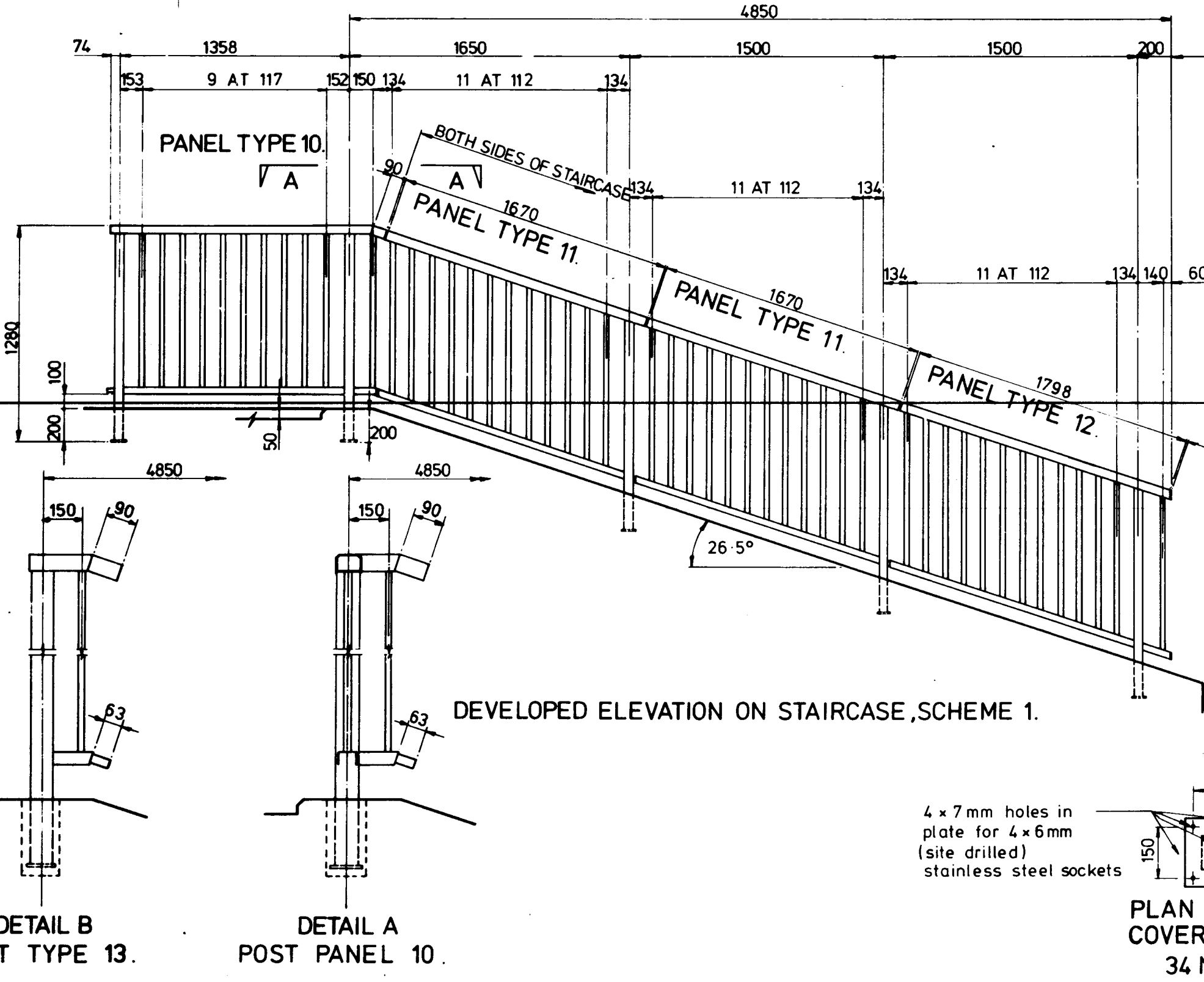
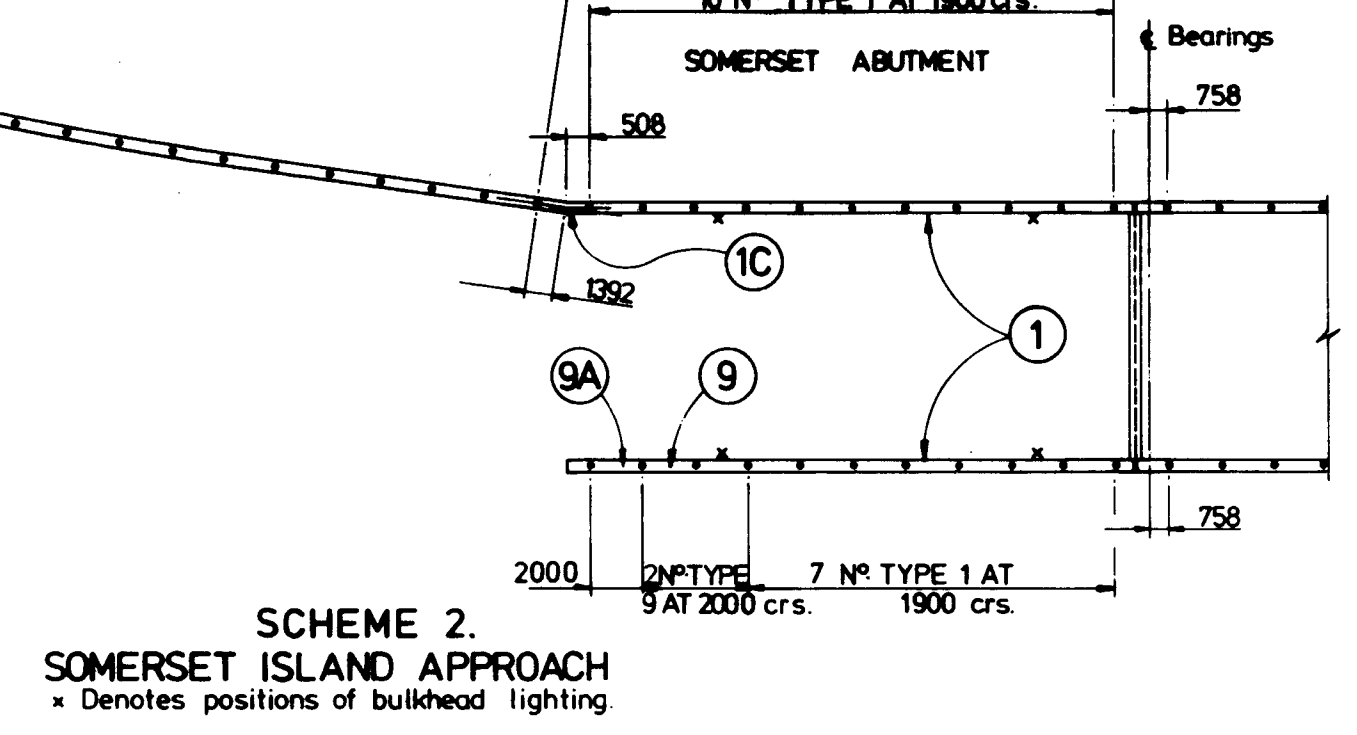
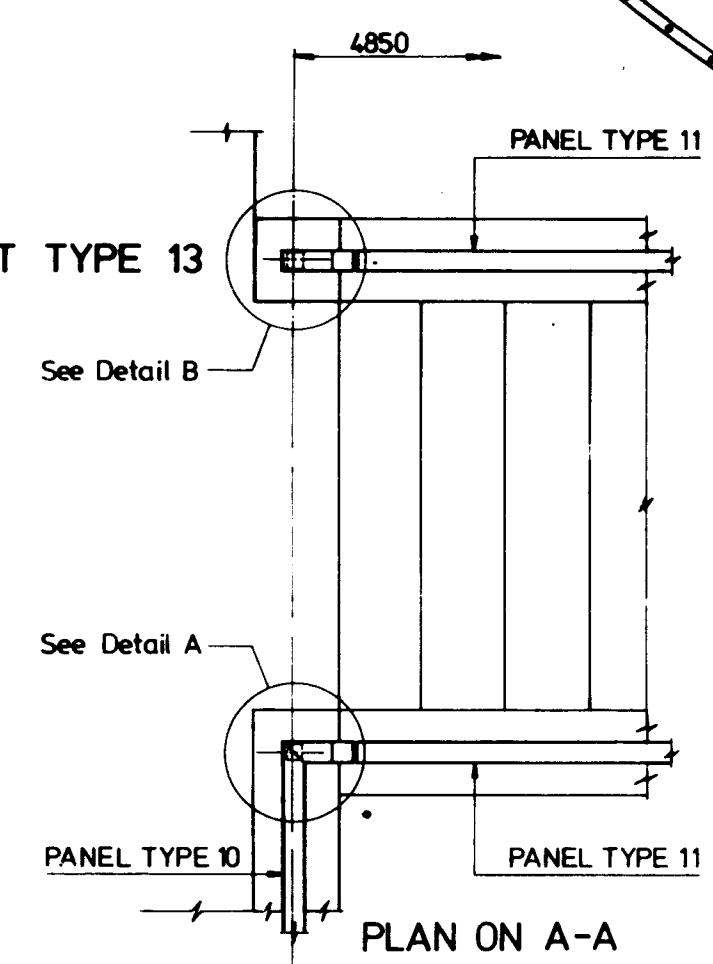
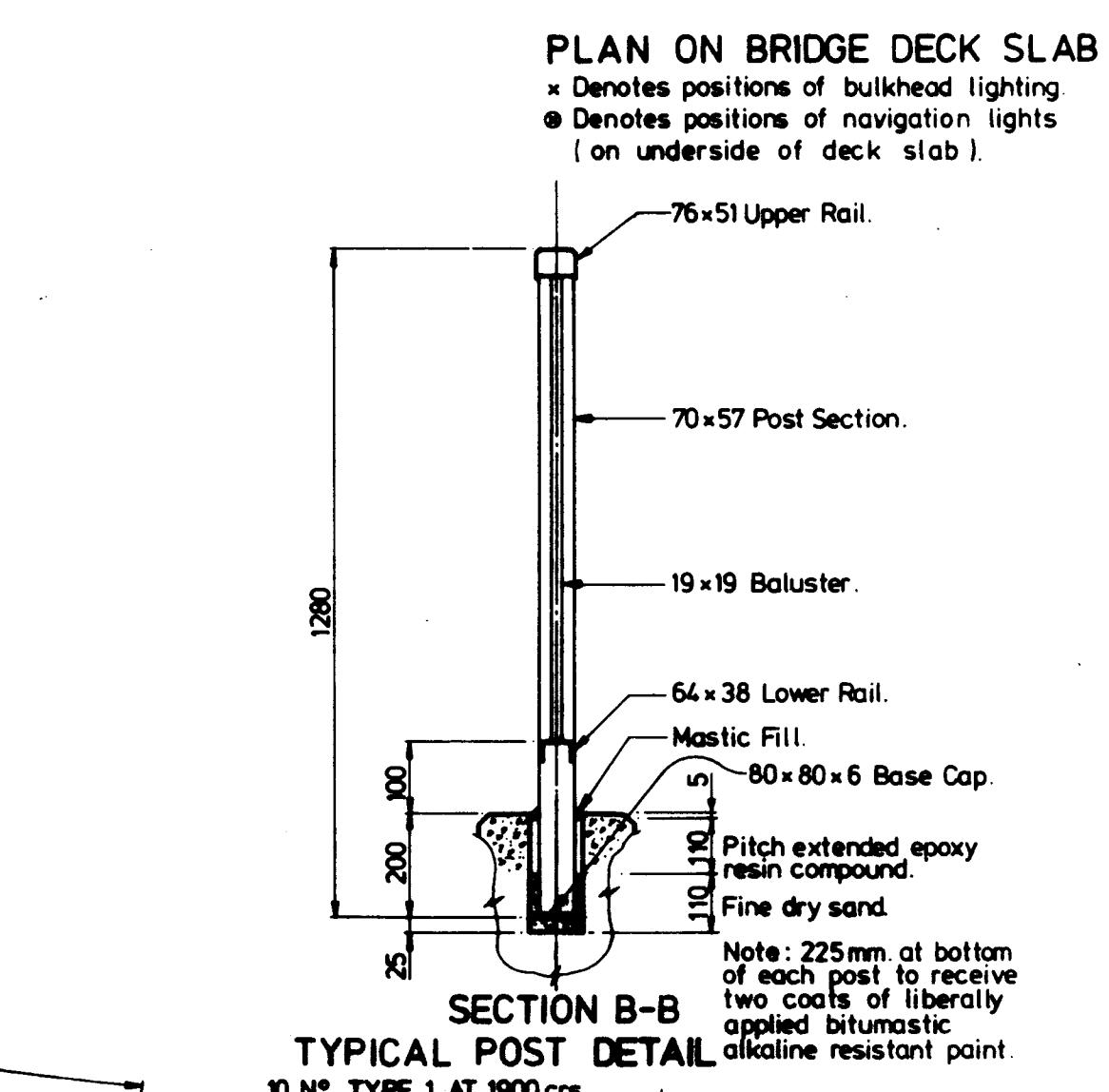
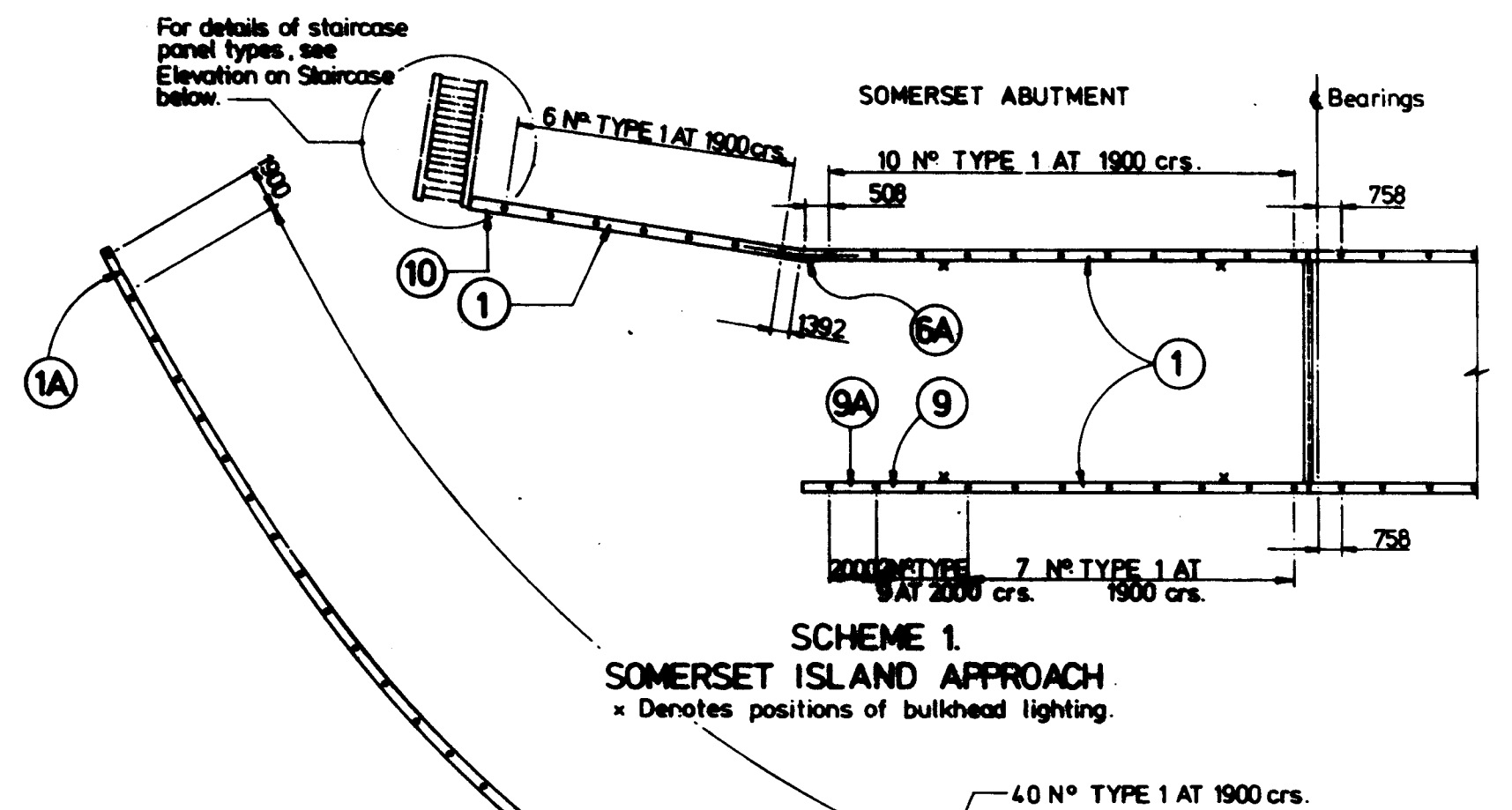
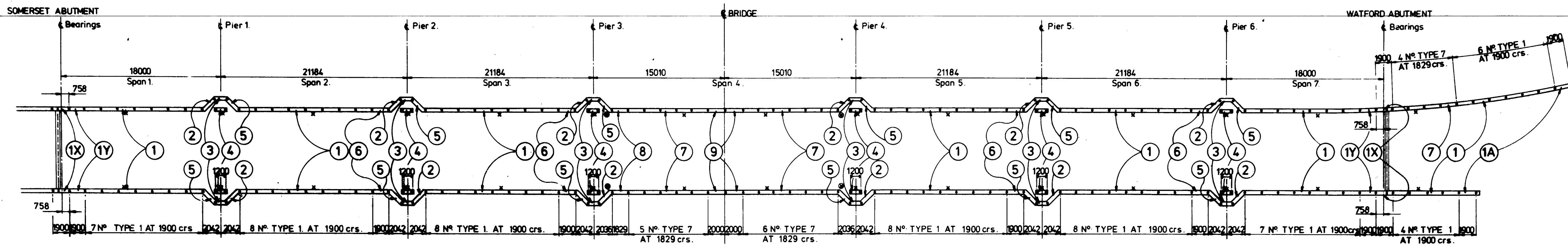

- Notes :-
- All dimensions are in millimetres.
 - Pedestrian Guardrail (P4) to comply with BS.3049-1968 and Technical Memorandum No BES (DOE).
 - Method of erection to be agreed with the E.R.
 - Protective treatment of guardrail.
 a) all guardrail panels to be shop painted b) after assembly the guardrail to receive a finish coat of paint.
 - Bulkhead lighting — protective treatment to light housing to the requirements of the Engineer.
 - This drawing to be read in conjunction with the following drawings :-
 7722/3/6 — Somerset Island Approach, Scheme 1
 7722/3/7 — Somerset Abutment, GA Scheme 1
 7722/3/9 — Somerset Island Approach, Scheme 2
 7722/3/10 — Somerset Abutment, GA Scheme 2
 7722/3/12 — Watford Abutment, GA.
 7722/3/17 — Deck Slab, General Arrangement.

GUARDRAIL SCHEDULE		No. of
PANEL TYPE	COMMENTS	panels
1		90
1B	as standard panel type 1 + pft. for bulkhead lighting	12
1X	length of top & bot rail differ from standard panel type	4
1Y	spigot end to rails differ from standard panel type	4
2		12
3		12
4		12
5		12
6		8
7		16
7A	as standard panel type 7 + pft. for bulkhead lighting	4
8		2
9		4
BRIDGE DECK		
STANDARD JOINTS		
	Top rail, 1 No. spigot 152 long, 2 No. 6mm dia. pan-head setscrews = 20mm long	16
	2 No. spring washers & 2 No. plain washers	16
	Bottom rail	16
MOVEMENT JOINTS		
	Top rail 1 No. spigot 150 long, 2 No. 6mm dia. pan-head setscrews = 20mm long	4
	2 No. spring washers & 2 No. plain washers	4
	Bottom rail	4
	1 No. 6mm dia. pan-head setscrew = 20mm long	4
	1 No. spring washer & 1 No. plain washer	4
WATFORD ABUT.		
SCHEME 1		
	1	9
	1A	2
	1B	1
	7	3
	7A	1
STANDARD JOINTS		
	Top rail	16
	Bottom rail	16
SCHEME 2		
	1	5
	1B	3
	6A	2
		1
	9	1
	9A	1
	9B	1
	10	1
	11	4
	12	2
	13	1
STANDARD JOINTS		
	Top rail	24
	Bottom rail	24
SCHEME 2		
	1	5
	1A	1
	1B	3
	1C	1
		1
	9	1
	9A	1
	9B	1
	10	1
	11	6
	12	3
	13	1
STANDARD JOINTS		
	Top rail	24
	Bottom rail	24

REV.	DESCRIPTION	DATE	CHECKED
GOVERNMENT OF BERMUDA			
NEW WATFORD BRIDGE			
GUARDRAIL AND LIGHTING DETAILS			
PUBLIC WORKS DEPT.		G. MAUNSELL & PARTNERS	
HAMILTON 5		CONSULTING ENGINEERS	
BERMUDA		LONDON S.E. 20.	
SCALE: 1:20, 1:200, 1:10 & 1:2	DATE: MAY 1979		DRAWN BY: S. D.
			7722/3/19

Note - Dimension 'X' to suit bearing manufacturer's standard mould

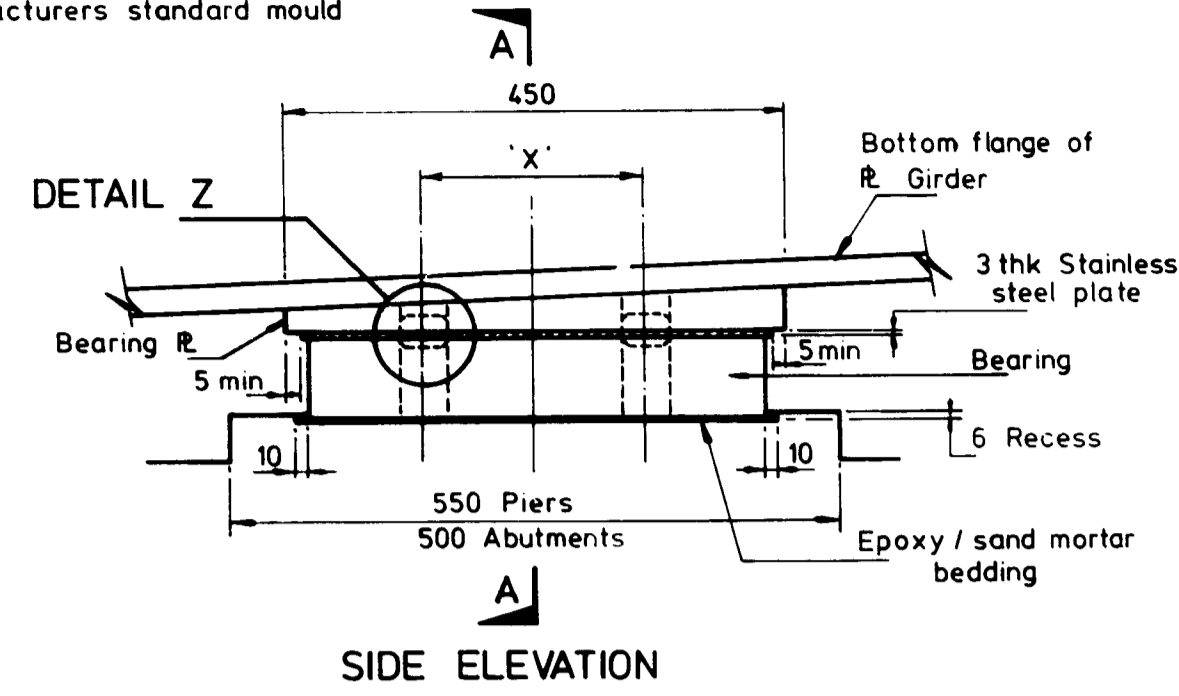

SIDE ELEVATION

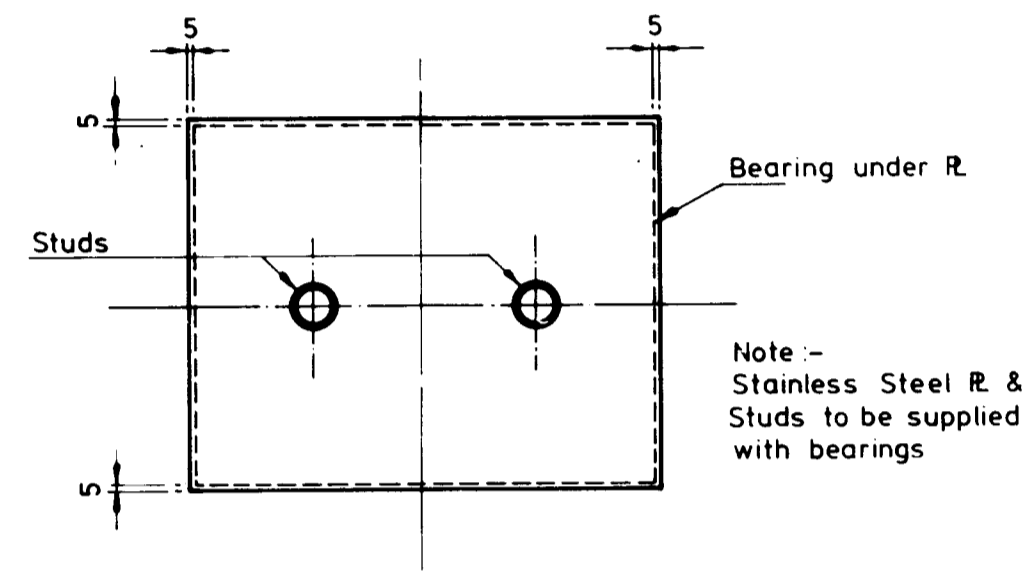

PLAN ON STAINLESS STEEL PLATE

Note - Epoxy to be applied to both surfaces of plate prior to fixing

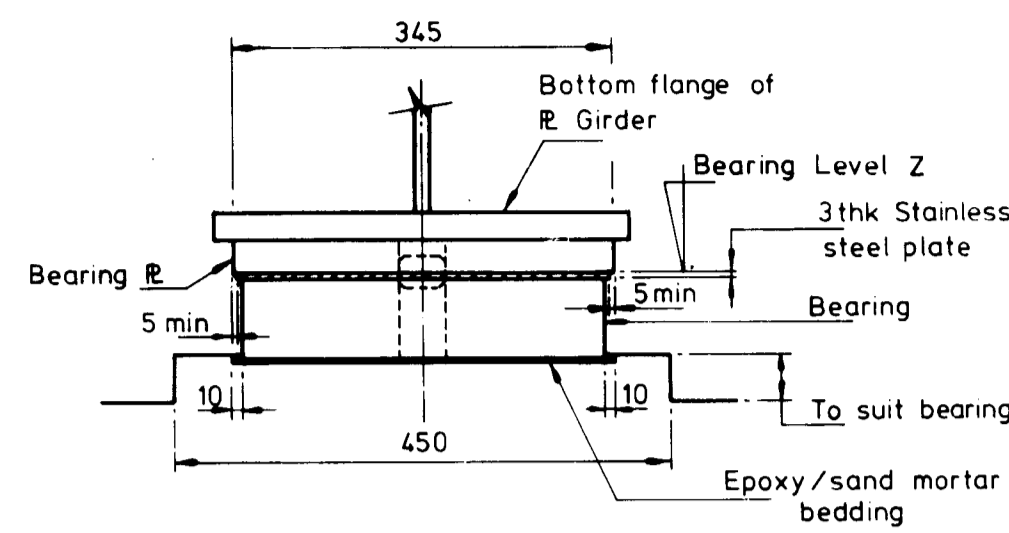

SECTION A-A

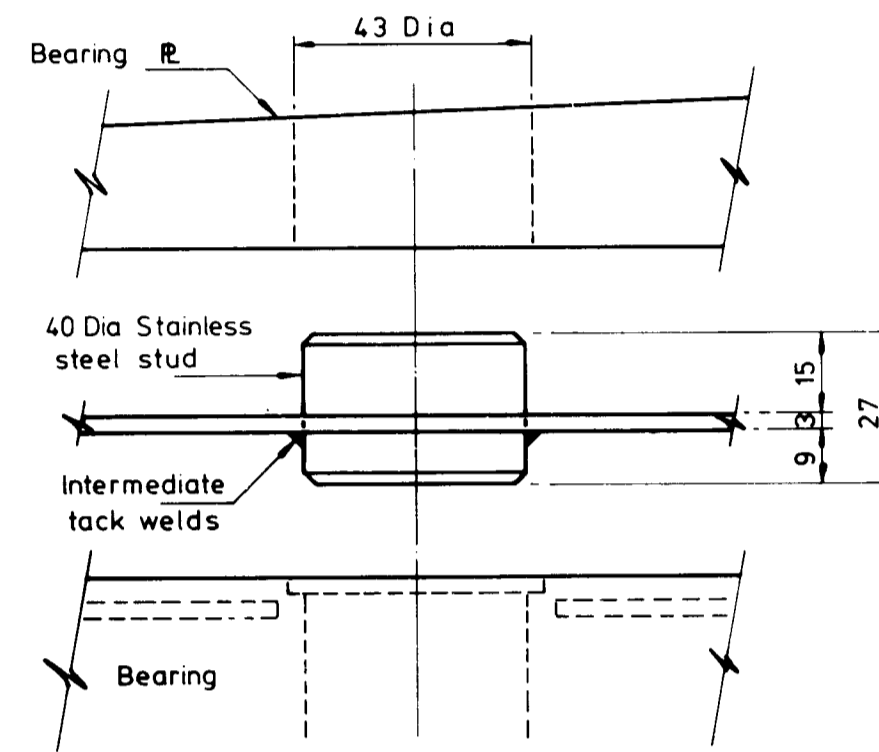

DETAIL Z (exploded view)

STANDARD BEARING DETAILS

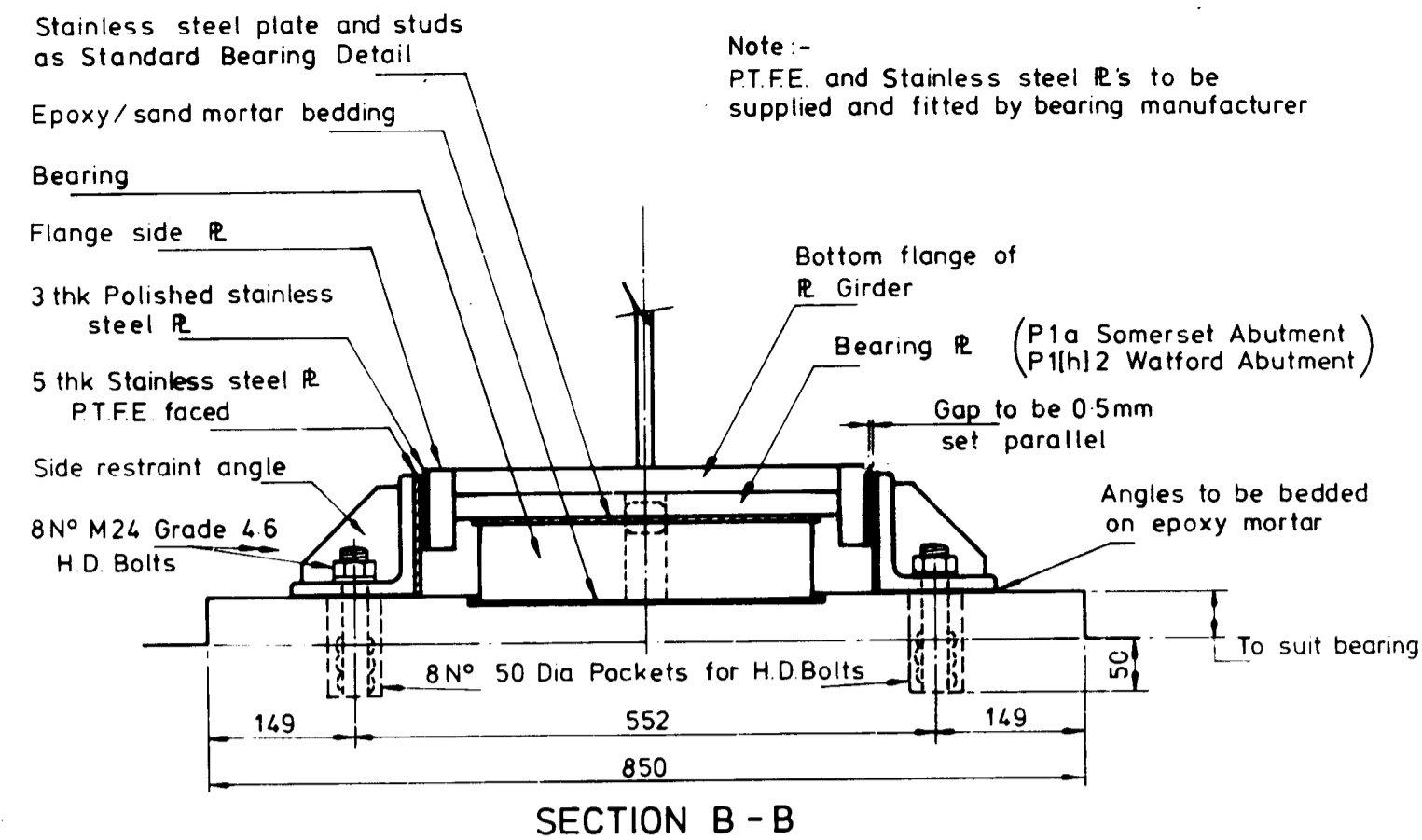

SECTION B-B

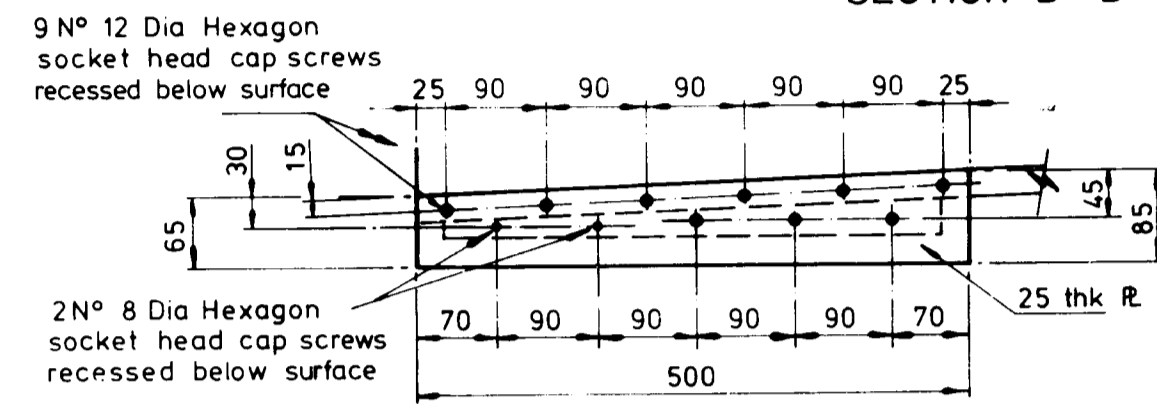

FLANGE SIDE PLATE DETAIL (2° Thus and 2° Handed)

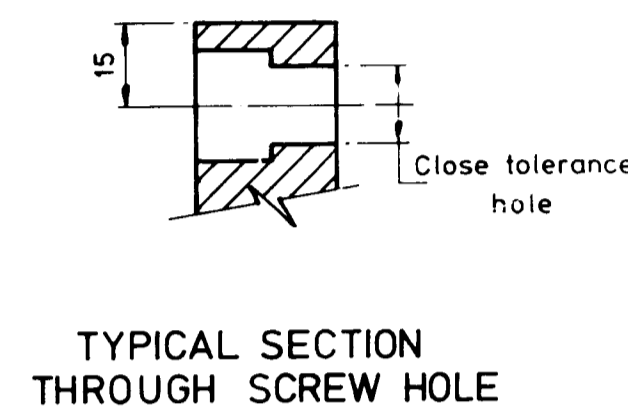

TYPICAL SECTION THROUGH SCREW HOLE

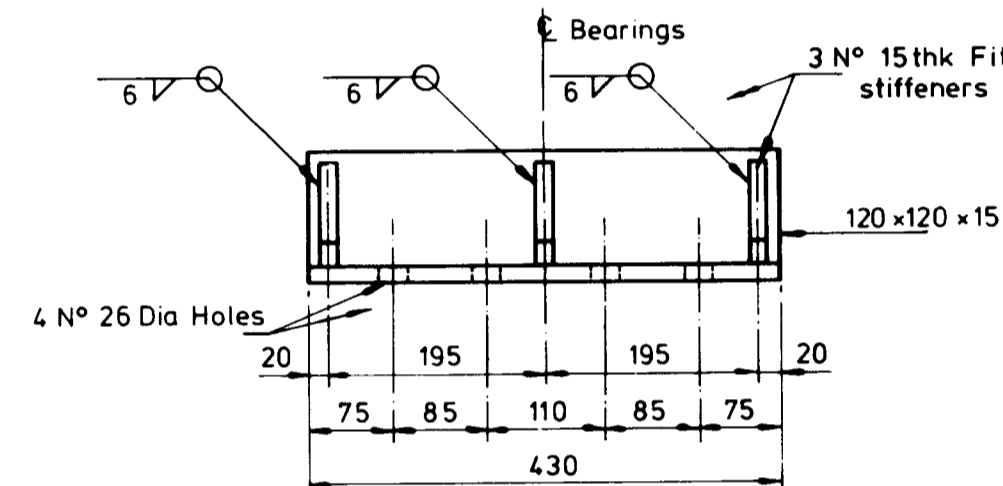

ELEVATION

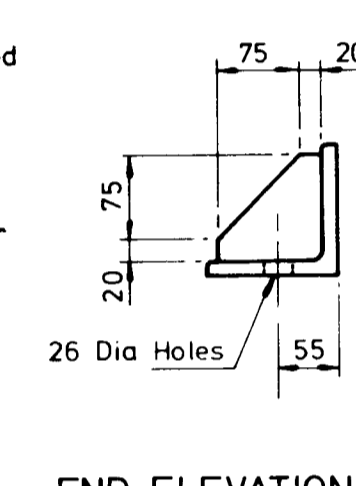

END ELEVATION

SIDE RESTRAINT ANGLE (4° Thus)

RESTRAINED BEARING DETAILS (Bearings SA-2 & WA-2)

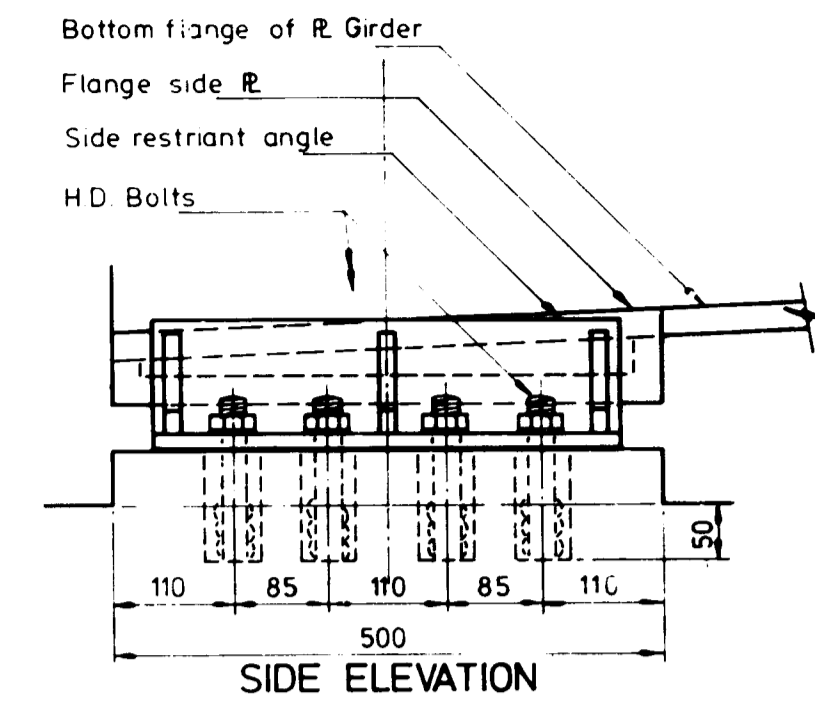

SIDE ELEVATION

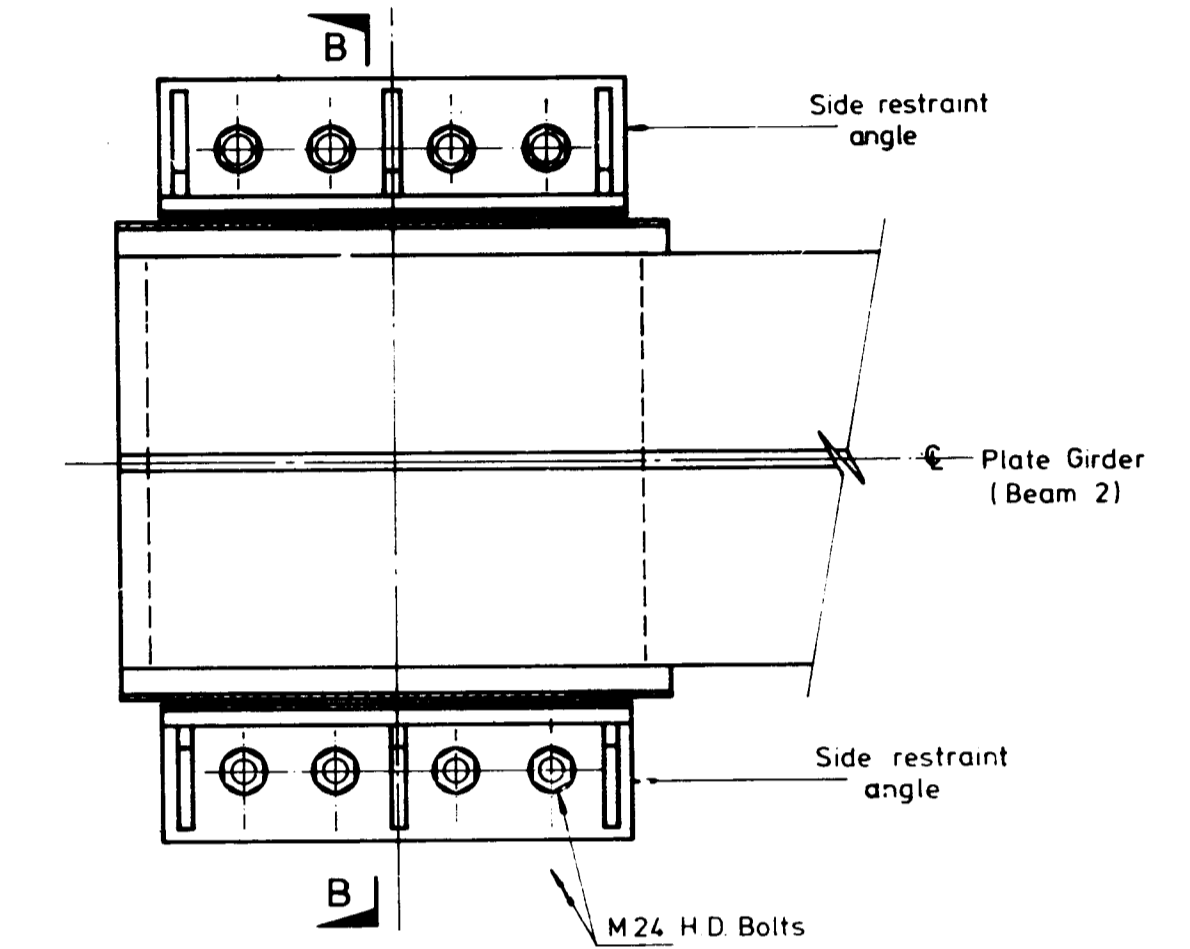

PLAN

Location	No of bearings	vertical loading (kN)						longitudinal movement (mm)	maximum rotation $\times 10^3$ radians	maximum longitudinal shear stiffness kN/mm	bearing test
		Beams 1 and 4			Beams 2 and 3						
		DL	DL+SDL	DL+HA	DL	DL+SDL	DL+HA				
Somerset Abutment	4	93	222	355	130	168	446	± 19.5	5.2	2.0	
Pier 1	4	303	659	922	425	557	1059	± 13.0	1.5	2.0	
Pier 2	4	269	611	878	374	487	994	± 6.5	2.5	2.0	
Pier 3	4	392	816	1120	538	718	1255	± 0	4.5	1	
Pier 4	4	392	816	1120	538	718	1255	± 9.0	4.5	2.5	
Pier 5	4	269	611	878	374	487	994	± 15.5	2.5	2.0	
Pier 6	4	303	659	922	425	557	1059	± 21.0	1.5	2.0	
Watford Abutment	4	93	222	355	130	168	446	± 28.0	5.2	2.0	

BEARING SCHEDULE

Note: - bearings referenced thus



BEARING NOTES -

- All bearings are to be in accordance with D.O.T. Technical Memorandum (Bridges) N° BE 1/76 - "Design Requirements for Elastomeric Bridge Bearings" (including addendums 1, 2 and 3)
- Bearings specified for any particular location shall be subject to the approval of the Engineer and the proposals must be accompanied by evidence of satisfactory independent tests carried out on similar bearings
- Bearing tests to be conducted on each bearing type as shown on the Bearing Schedule
- Bedding details for the bearings shall be subject to the approval of the Engineer
- All bearings to be set horizontal
- Allowable contact pressure on underside of bearing shall be 12.5 N/mm² (maximum)
- The rotations shown in the Bearing Schedule are for the "in-service" condition
- The Contractor must ensure that the bearings are not overstressed or subjected to excessive rotation during construction. Reasonable allowance shall be made when selecting the bearings for the "built-in" rotation caused by construction tolerances
- Maximum plan size of bearing to be 430 (longitudinal) \times 305

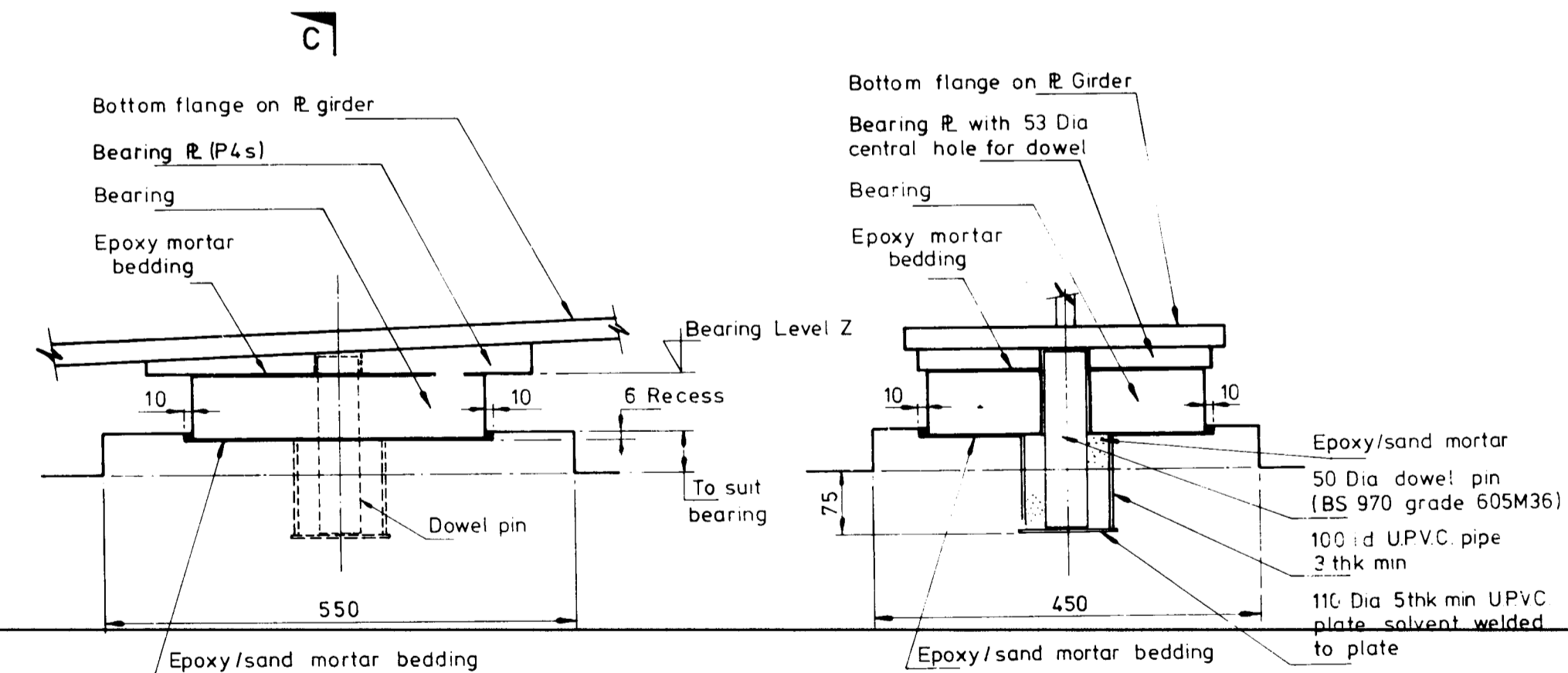

SECTION C-C

FIXED BEARING DETAILS (Bearing 3-2, 1N° Thus)

Note: - Dowel pin to be fixed over-length and cut to give a 5mm end clearance on centre-line. Allowance to be made for bedding and compressive deformation of bearing under dead load

Location	Bearing Level 'Z'			
	Beam 1	Beam 2	Beam 3	Beam 4
Somerset Abutment	4.342	R 4.342	4.342	4.342
Pier 1	5.116	5.116	5.116	5.116
Pier 2	5.972	5.972	5.972	5.972
Pier 3	6.647	F 6.647	6.647	6.647
Pier 4	6.647	6.647	6.647	6.647
Pier 5	5.972	5.972	5.972	5.972
Pier 6	5.109	5.114	5.124	5.135
Watford Abutment	4.270	R 4.339	4.407	4.470

F = fixed
R = restrained } see details

TABLE OF BEARING LEVELS

- GENERAL NOTES -
- All dimensions are in millimetres
 - All structural steelwork to BS 4360 1972 grade 43c
 - Weld to be 6mm fillet
 - Holding down bolts, nut and washers to be sherardized
 - Side restraint angles and flange side plates to be hot dipped galvanized and shop painted
 - All stainless steel to be grade 316S16
 - This drawing to be read in conjunction with the following -
 - 7722/3/7 - Somerset Abutment GA scheme 1
 - 7722/3/10 - Somerset Abutment GA scheme 2
 - 7722/3/12 - Watford Abutment GA
 - 7722/3/14 - Details of Piers
 - 7722/3/15 - Deck Steelwork Sheet 1
 - 7722/3/16 - Deck Steelwork Sheet 2

REV.	DESCRIPTION	DATE	CHECKED
GOVERNMENT OF BERMUDA			
NEW WATFORD BRIDGE			
BEARING SCHEDULE AND DETAILS			
PUBLIC WORKS DEPT. HAMILTON 5 BERMUDA		G. MAUNSELL & PARTNERS CONSULTING ENGINEERS LONDON S.E. 20.	
SCALE 1:1, 1:5	DRG. NO. 7722/3/20		
DATE MAY 1979	DRAWN BY G.J.H.		

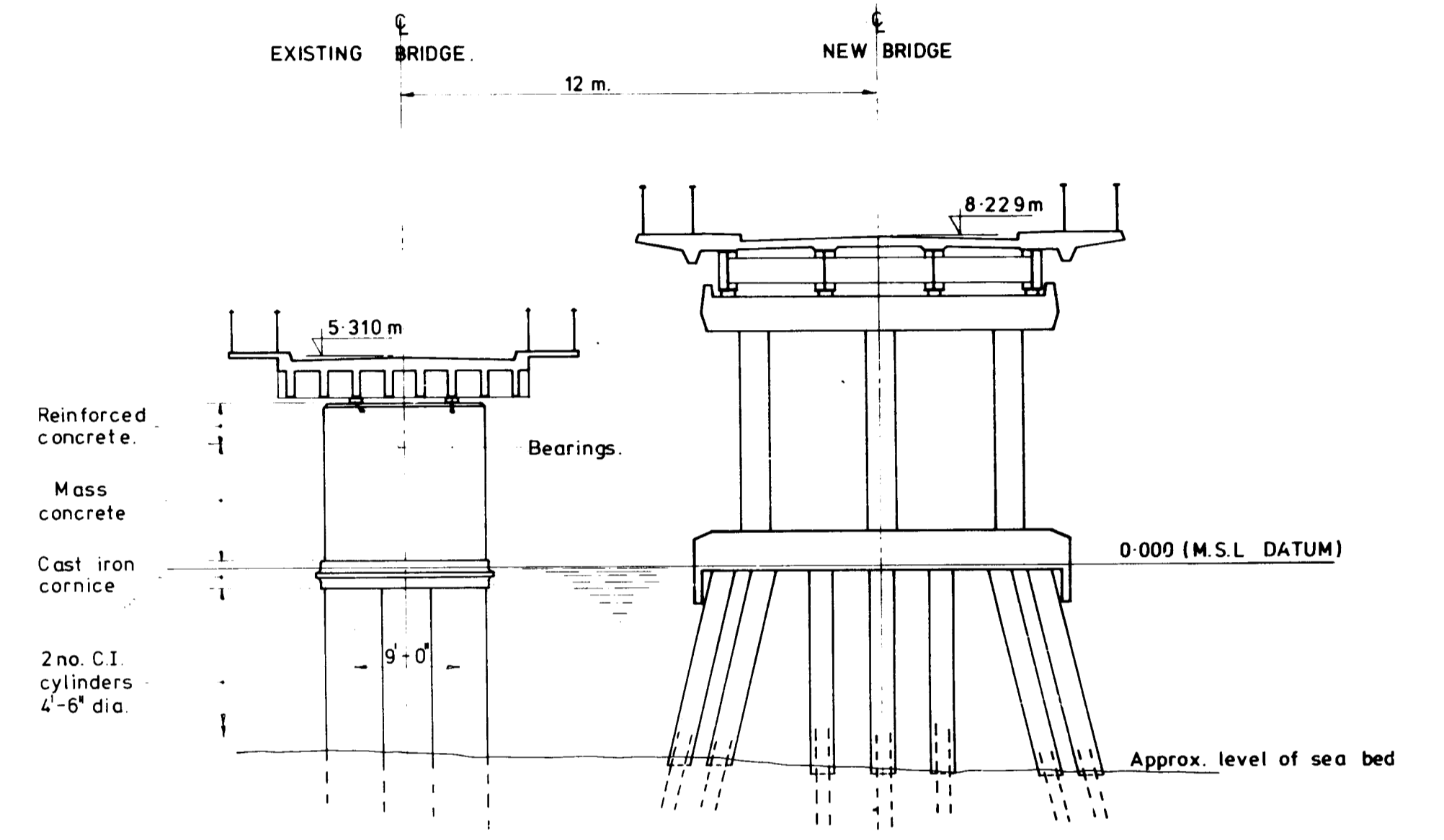
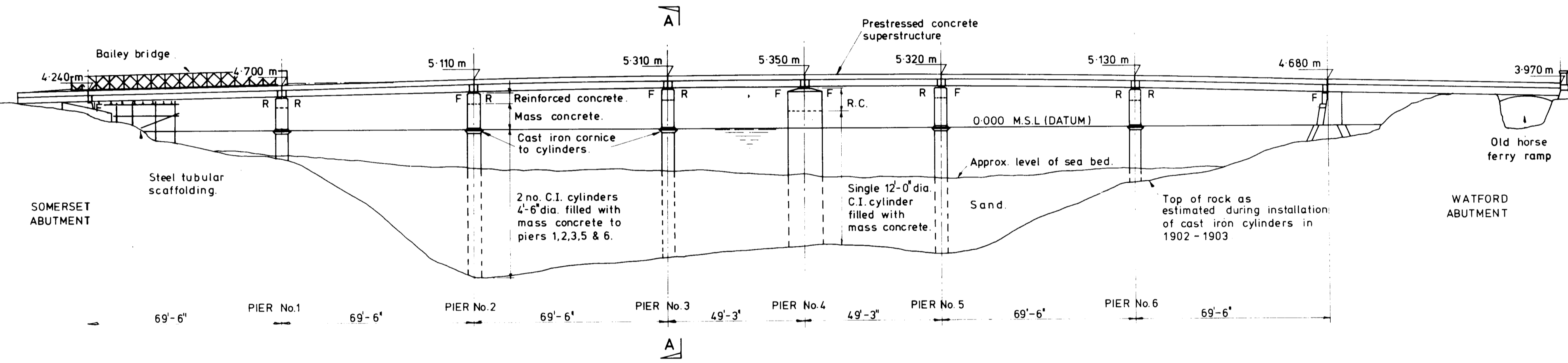
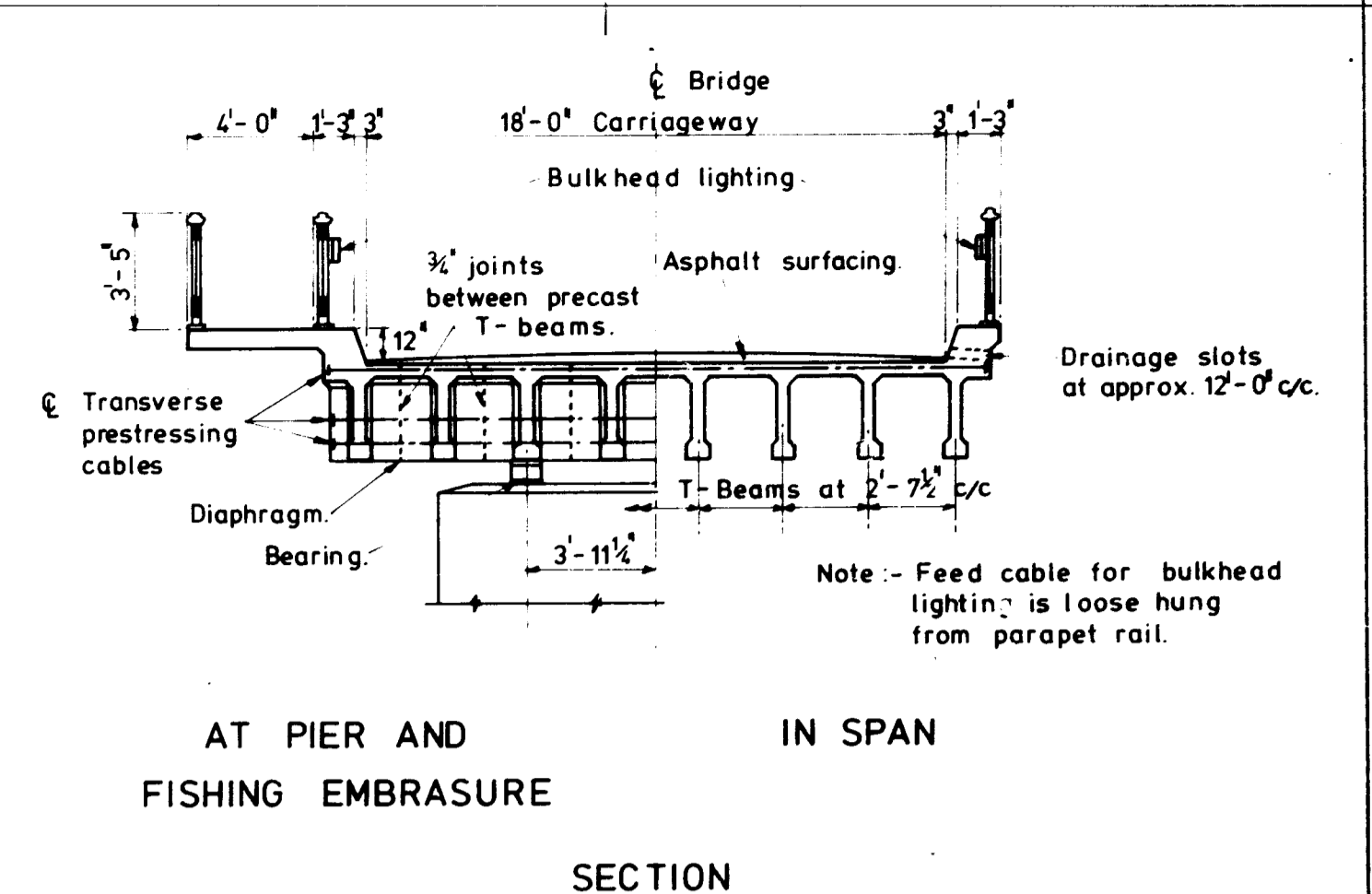
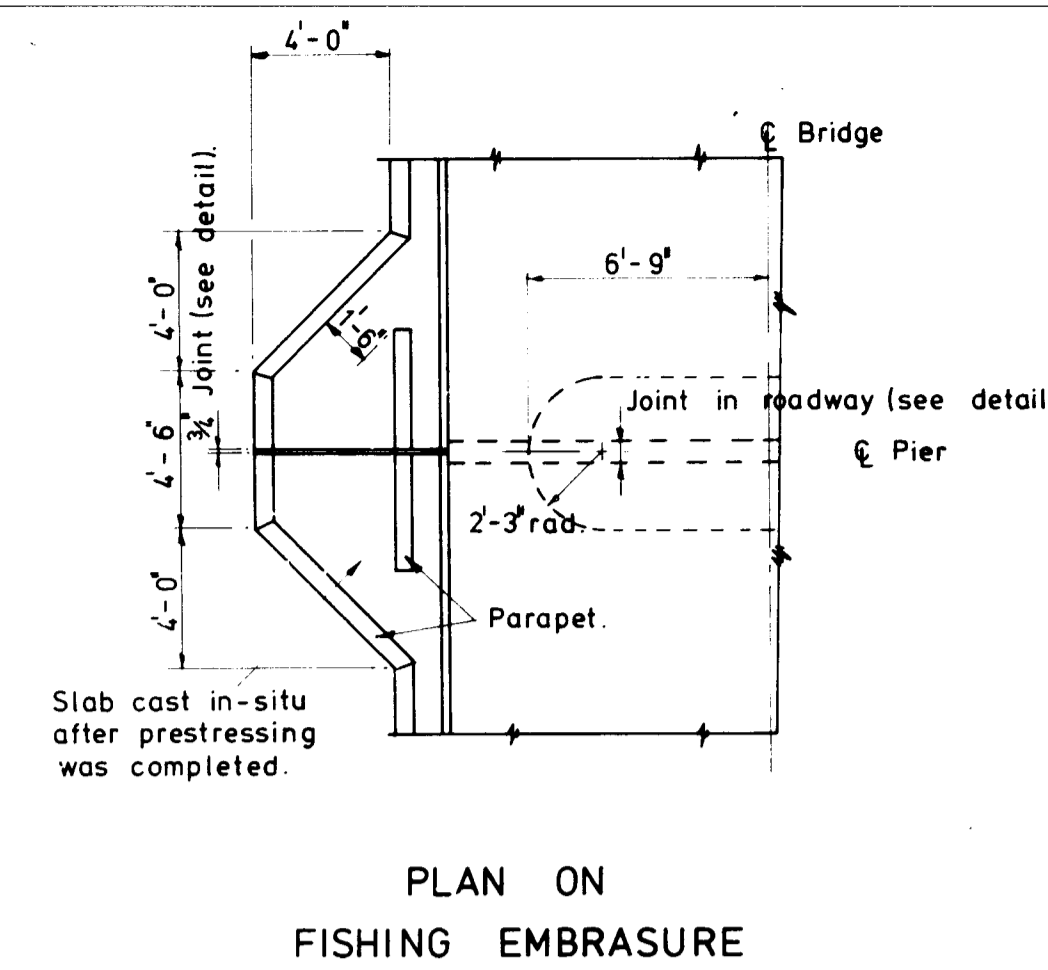
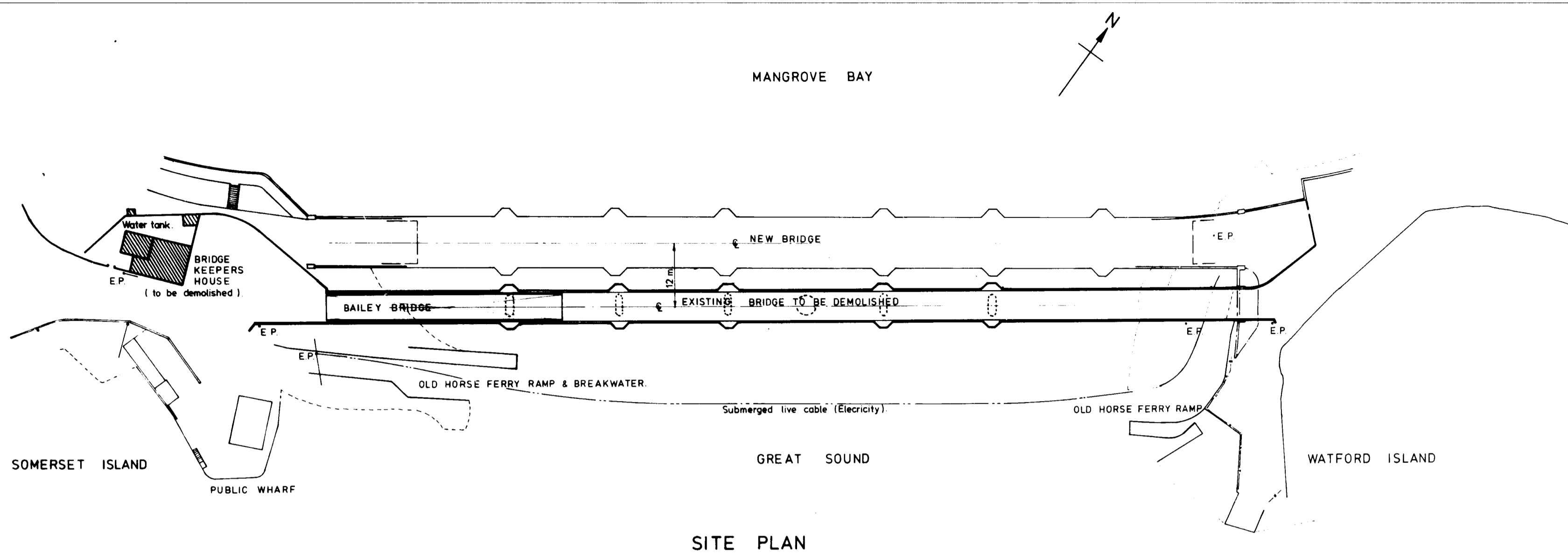

ELEVATION OF BRIDGE
NOTE :- Road levels are given on ϕ of bridge in metres.
F = Fixed bearing R = Roller bearing.

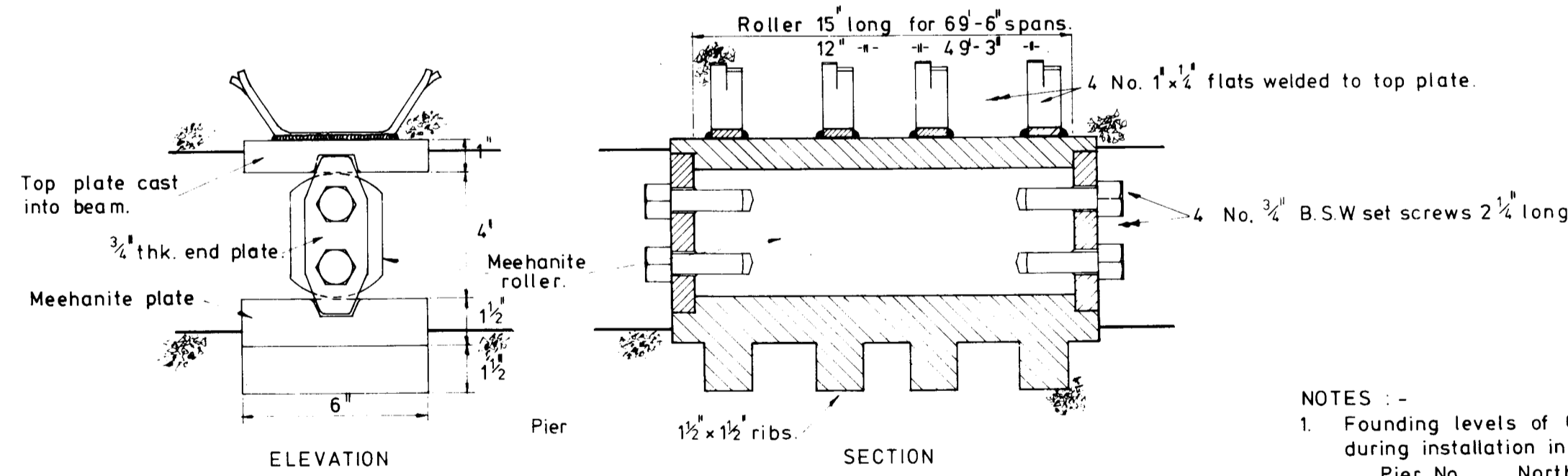
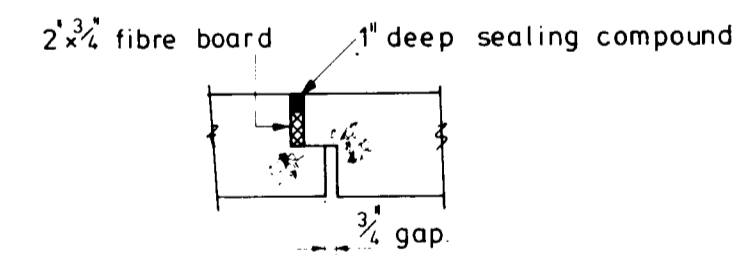
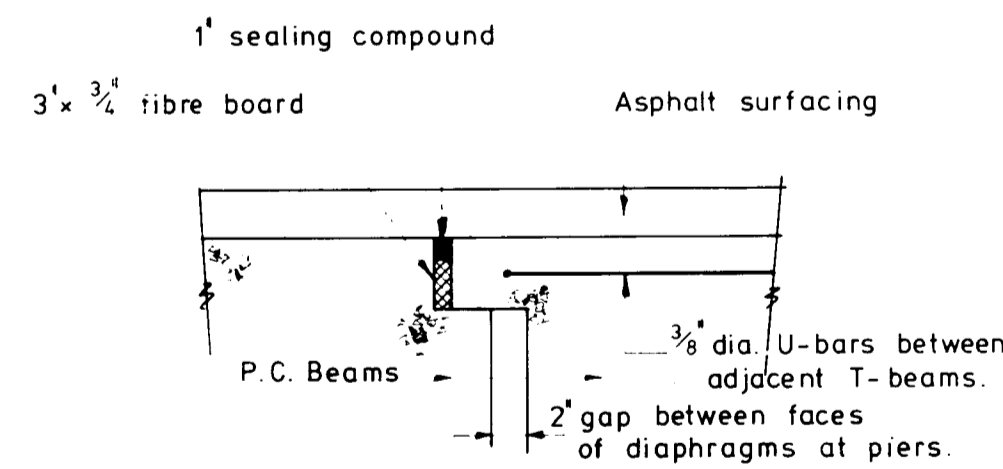

- NOTES :-
1. Founding levels of C.I. cylinders as recorded during installation in 1902 - 1903 -
- | Pier No. | North | South |
|----------|----------|----------|
| 1. | - 4.5 m | - 3.9 m |
| 2. | - 16.6 m | - 15.8 m |
| 3. | - 14.2 m | - 14.5 m |
| 4. | - | - 13.2 m |
| 5. | - 14.4 m | - 14.5 m |
| 6. | - 6.5 m | - 6.6 m |
2. Cylinders to be demolished to a level at least 0.5 metres below existing sea bed.
 3. This drawing to be read in conjunction with Bridge Details Sheet 2. drg. no. 7722/4/2.

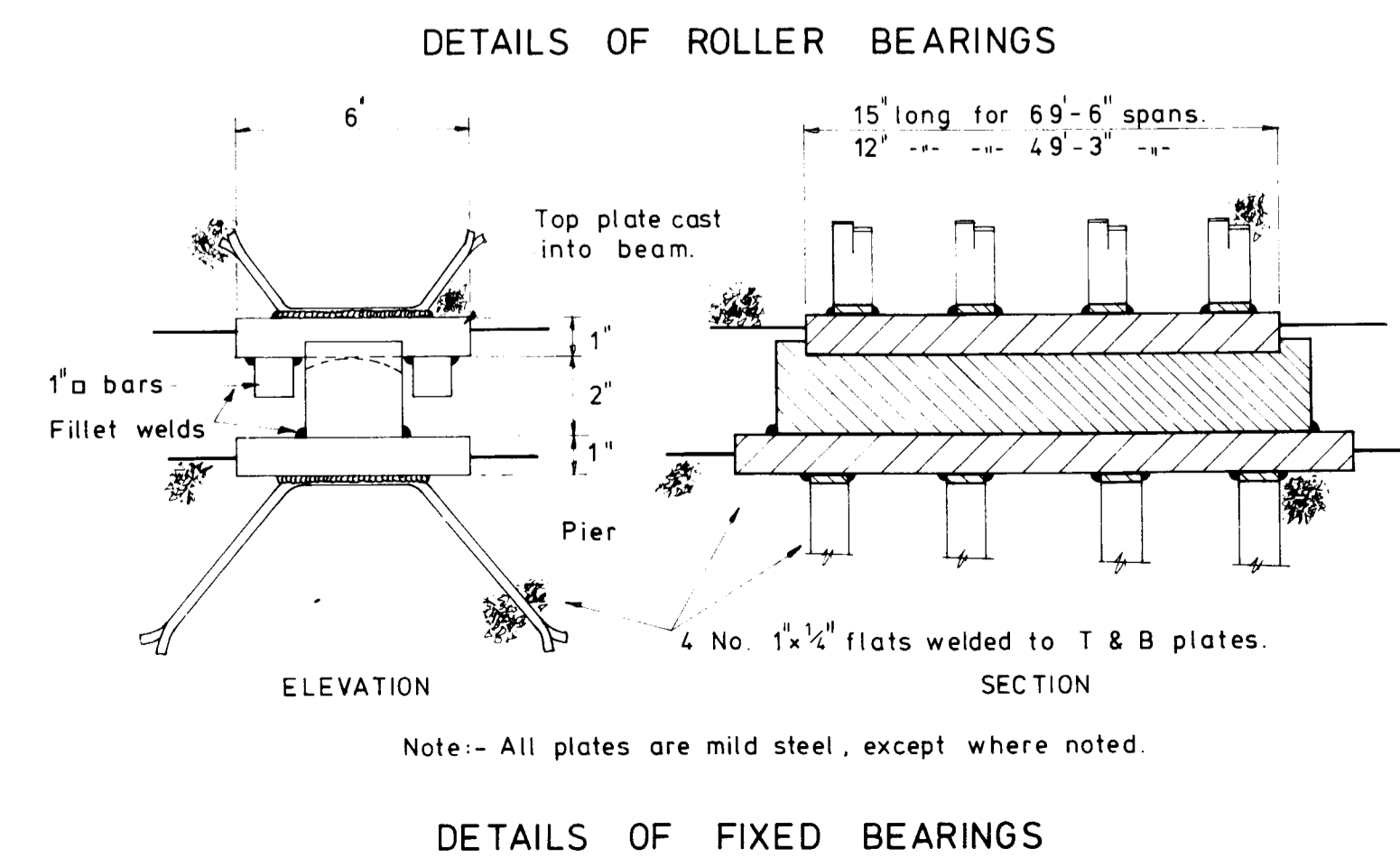
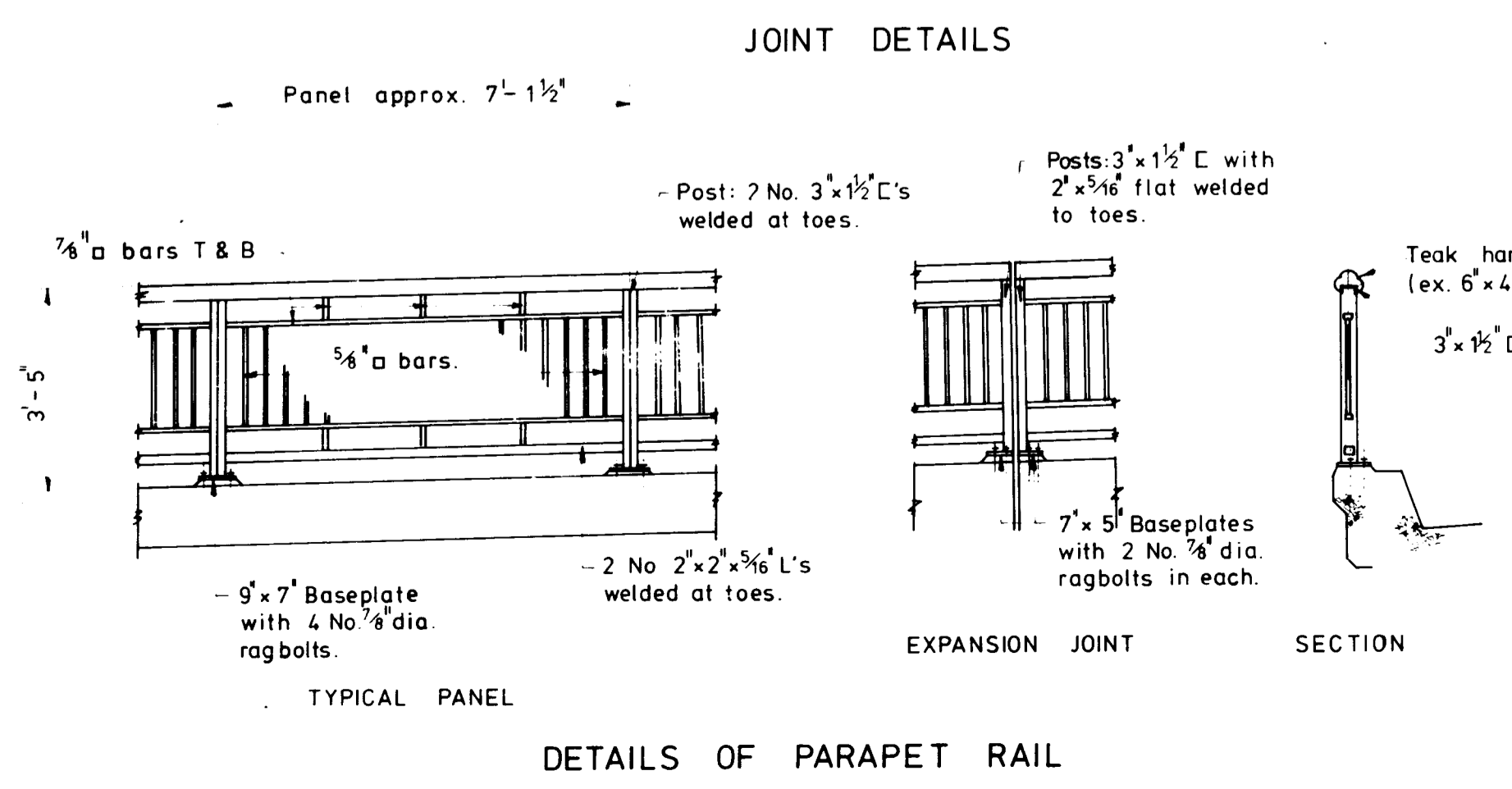

REV.	DESCRIPTION	DATE	CHECKED
GOVERNMENT OF BERMUDA			
NEW WATFORD BRIDGE			
DEMOLITION OF EXISTING WATFORD BRIDGE			
BRIDGE DETAILS SHEET 1			
PUBLIC WORKS DEPT. HAMILTON 5 BERMUDA		G. MAUNSELL & PARTNERS CONSULTING ENGINEERS LONDON S.E. 20.	
SCALE:		DRG. NO.	
DATE: MAY 1979.	DRAWN BY: ME.	7722/4/1	

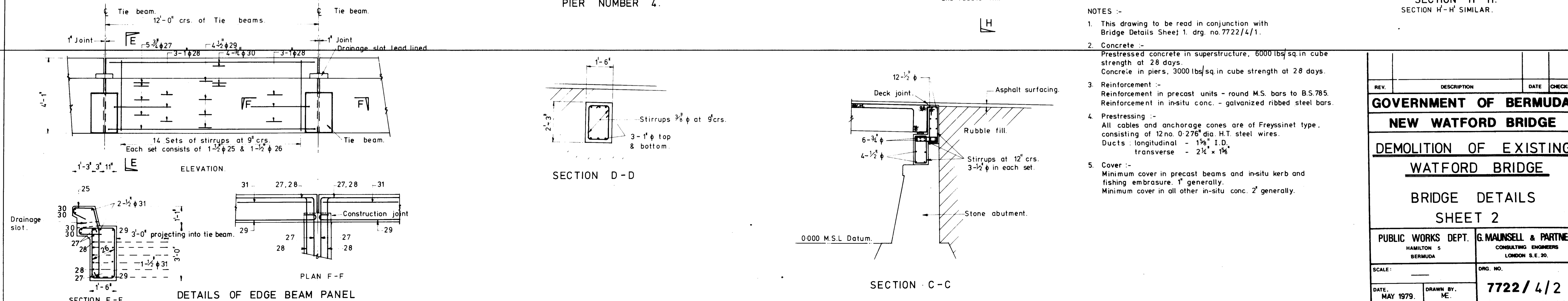
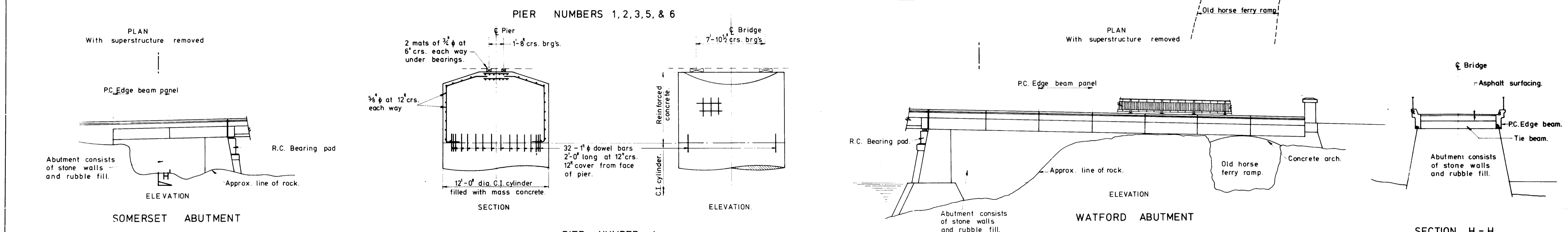
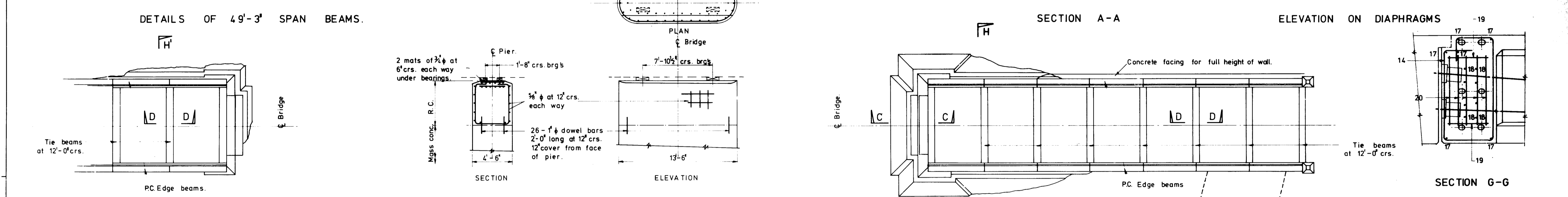
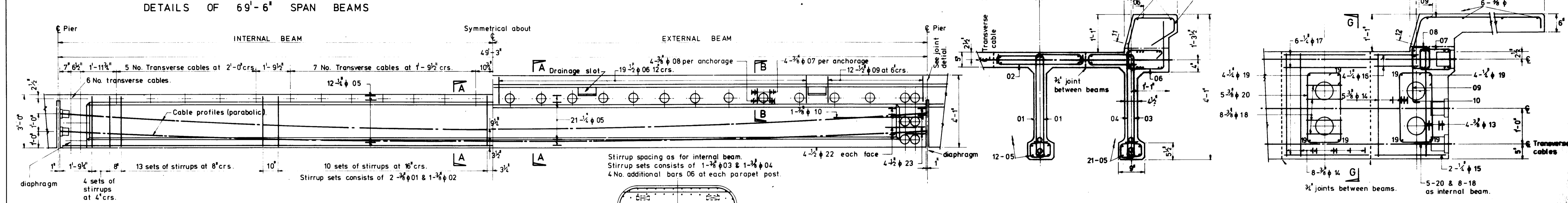
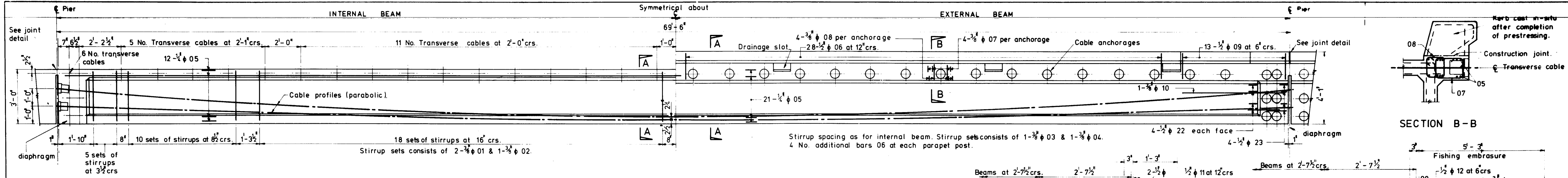

NORTH SIDE

SOUTH SIDE

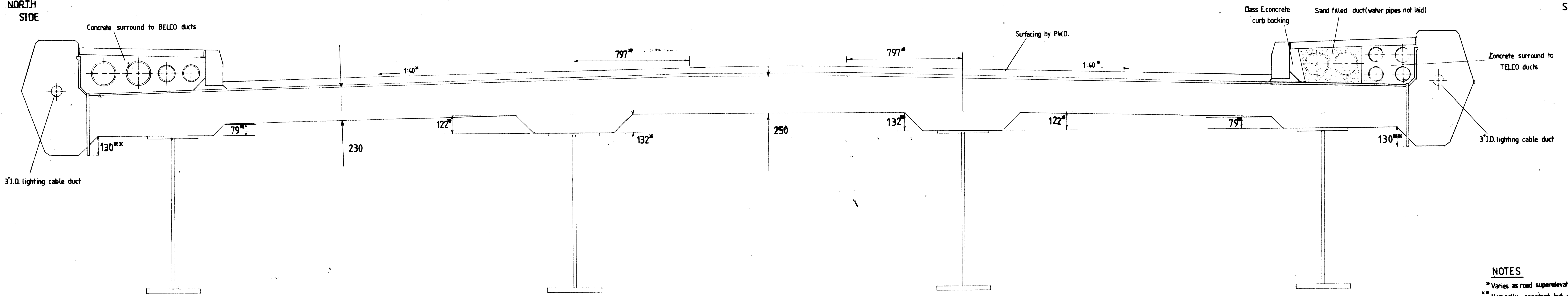

TYPICAL CROSS SECTION THROUGH DECK
SCALE 1:10

NOTES

- *¹Varies as road super-elevates
- **²Nominally constant but varies to take up slight deviations in steelwork profile.
- 1. Holding down bolts for prefabricated joints to be positioned by template to avoid interference with reinforcing steel.
- 2. Expansion joints and sleeves through abutment to be positioned in accordance with the Engineer's requirements.
- 3. Details of connection boxes and navigation light ducting are to remain as shown on drwg No. 7722/7/13.
- 4. All pulling boxes for BELCO and TELCO are to be omitted from bridge deck.

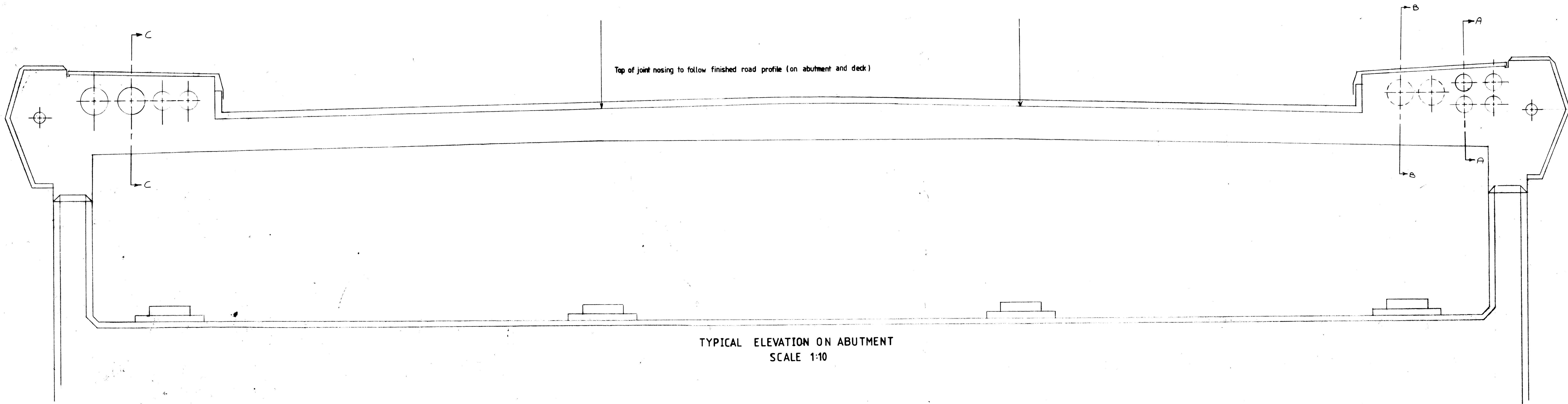

TYPICAL ELEVATION ON ABUTMENT
SCALE 1:10

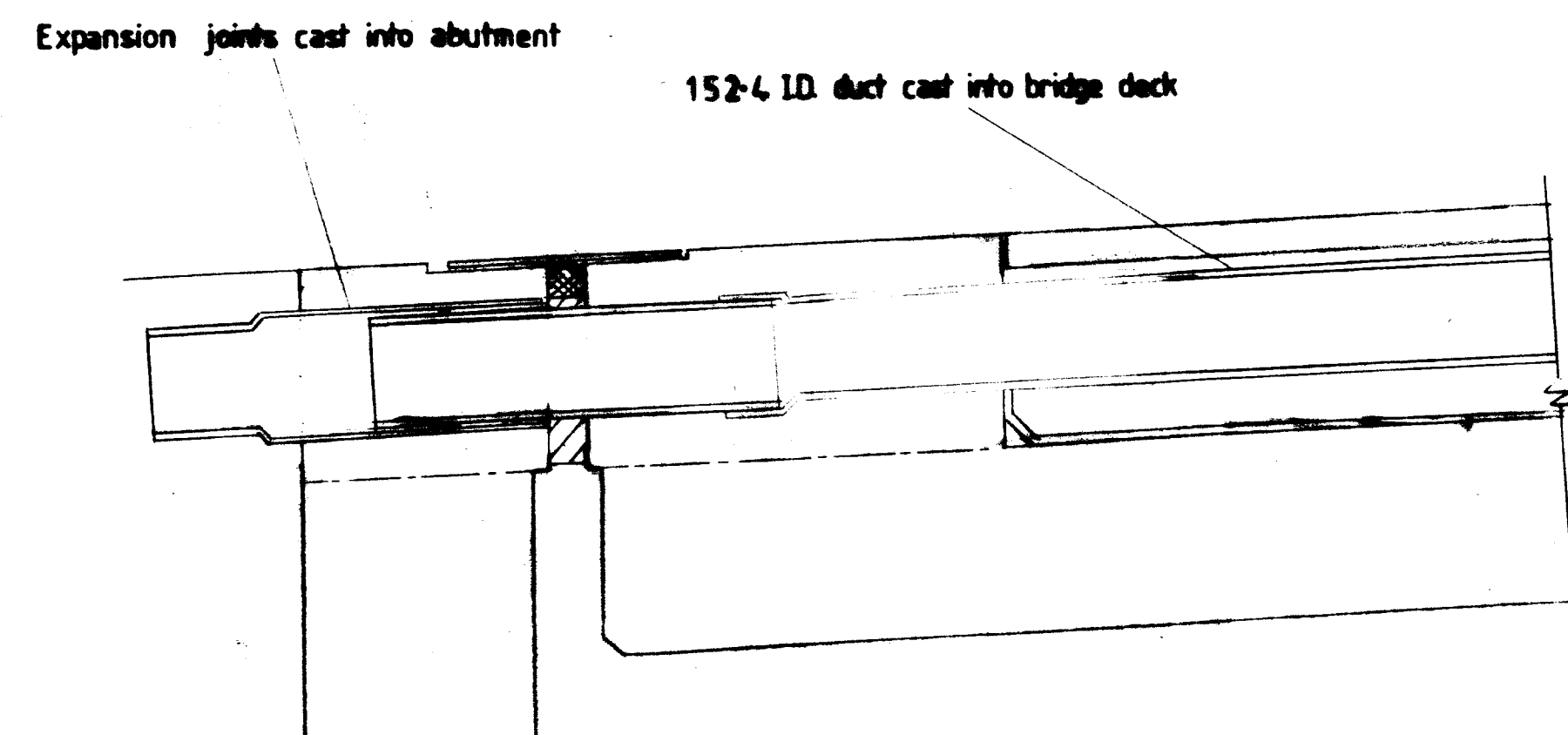

SECTION C-C
BELCO SERVICE DUCT
(Joints and ducting to be supplied by BELCO)
(Lighting cable duct in edge beam similar).
(Joints and ducting to be supplied by P.W.D.)

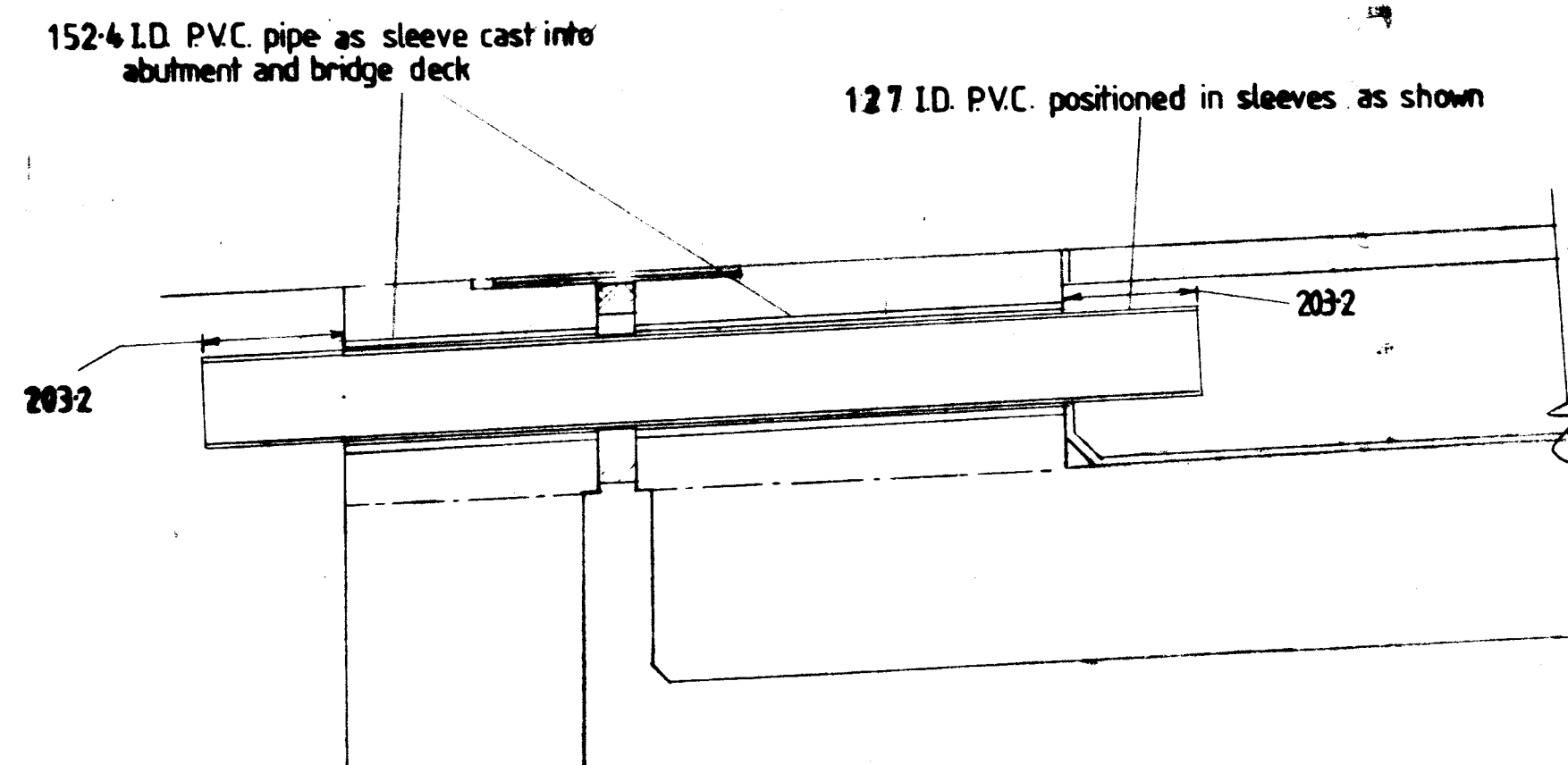

SECTION B-B
PROPOSED WATER PIPE DUCT
(All PVC pipe to be provided by P.W.D.)

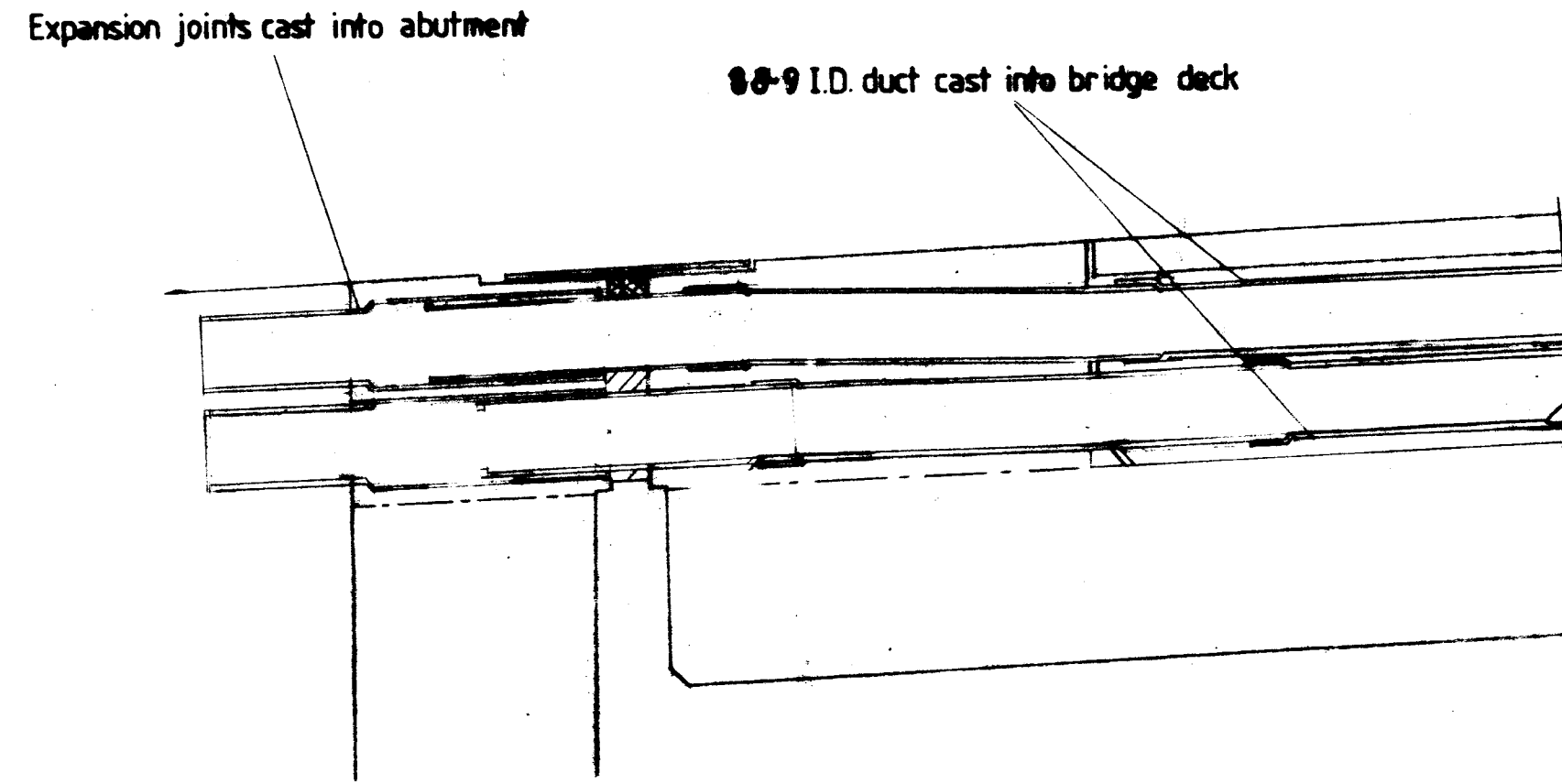

SECTION A-A
TELCO SERVICE DUCT
(Joints and ducting to be supplied by TELCO)

REV No.	DESCRIPTION	DATE	CHECKED
DRAWING TITLE TYPICAL DECK AND ABUTMENT TOP DETAILS			
PROJECT TITLE NEW WATFORD BRIDGE			
SURVEY BY	DESIGN BY	DATE	DATE
DATE	DATE	DATE	DATE
DRAWN BY W.E.E.	DRAWN BY	DATE	DATE
DATE FEB 1981	DATE	DATE	DATE
TRACED BY W.E.E.	APPROVED BY J.K.J.	DATE	DATE
DATE FEB 1981	DATE FEB 1981	DATE	DATE
SCALE 1:10			
DRAWING NUMBER 7722/7/PWD1			
PUBLIC WORKS DEPARTMENT P.O. BOX 525 HAMILTON 5 BERMUDA			